

ITEM NO.	PART NUMBER	QTY REQD.	NOMENCLATURE OR DESCRIPTION
1	40004	1	REAR BLADE FRAME WELDMENT
2	40006	1	SUPPORT WELDMENT
3	40007	1	LOCK PIN WELDMENT
4	40009	1	60" BLADE
5	40018	1	PIVOT PIN
6	10091	3	HEX BOLT (5/8" X 1 1/2")
7	40330	1	PIVOT BOLT
8	10166	10	LOCK NUT (5/8" PLATED)
9	11413	1	CASTLE NUT (FINE THREAD)
10	10207	2	FLATWASHER (1" PLATED)
11	10264	1	PLOW BOLT (5/8" X 2")
12	10307	2	CATEGORY I HITCH PIN
13	10420	2	CLIP PIN 3/16" DIA. X 3 3/4"
14	10431	1	60" CUTTING EDGE
15	11112	2	AB60 MODEL # DECAL
16	11032	2	HARDEE LOGO DECAL
17	11727	1	SERIAL NUMBER PLATE
18	10339	2	RIVET FOR SERIAL # PLATE
19	10262	6	PLOW BOLT (5/8" X 1 1/2")
20	10335	2 GAL	RED PAINT
21	10239	1	COTTER PIN (1/8" X 2")
22	40317	1	PARKING STAND WELDMENT
23	10393	1	UNIVERSAL CLEVIS PIN
24	10390	1	CLIP PIN (2")
25	11636	1	DECAL SAFETY SHEET
26	11010	1	MEDIUM H/W LOGO DECAL
27	11850	1	WEB DECAL
28	15852	2	RED REFLECTOR DECAL

DWG. NO.			REV.	
40001			G	
REV	CHANGE	BY	DATE	ECN
C	B.O.M. CHANGES	M.J.T	10/20/98	?
D	PARTS LIST CHANGES	M.J.T	12/8/98	0538
E	ADD STAND AND DECAL SHEET	M.J.T	5/13/99	0608
F	ADD LOGO AND MODEL DECALS	M.J.T	7/28/99	0649
G	CHANGE SERIAL # PLATE	T.R.M.	6/8/00	0792

ADD THIS REVISION AT NEXT DRAWING CHANGE

See ECR Change #0980 for Details
Add Qty. (1) Each 15852, 15853

All Dimensions in Inches Unless Otherwise Specified
Dimensions in [] are in Millimeters

Tolerances Unless Otherwise Specified
Fractional Dimensions $\pm 1/16"$ Angular Dimensions $\pm 1^\circ$
Decimal Dim. to Limits Shown All holes to be $+0$ / $-1/32$

DRAWN BY	M.J.T	12/8/98	HARDEE BY EVH MFG. CO. LORIS S.C.	
CHECKED BY			APPLICATION	OLD PART #
MATERIAL	R.M.N.		AB60	----
MANUFACTURED BY: HARDEE MFG. CO., LLC			DESCRIPTION AB60 REAR BLADE ASSEMBLY	
DO NOT SCALE	A	DWG. NO.	SHT. 1 OF 4 40001	

DWG. NO.

40001

REV.

G

REV	CHANGE	BY	DATE	ECN
C	B.O.M. CHANGES	M.J.T	10/20/98	?
D	PARTS LIST CHANGES	M.J.T	12/8/98	0538
E	ADD STAND AND DECAL SHEET	M.J.T	5/13/99	0608
F	ADD LOGO AND MODEL DECALS	M.J.T	7/28/99	0649
G	CHANGE SERIAL # PLATE	T.R.M.	6/8/00	0792

ADD THIS REVISION AT NEXT DRAWING CHANGE

See ECR Change #0980 for Details
Add Qty. (1) Each 15852, 15853

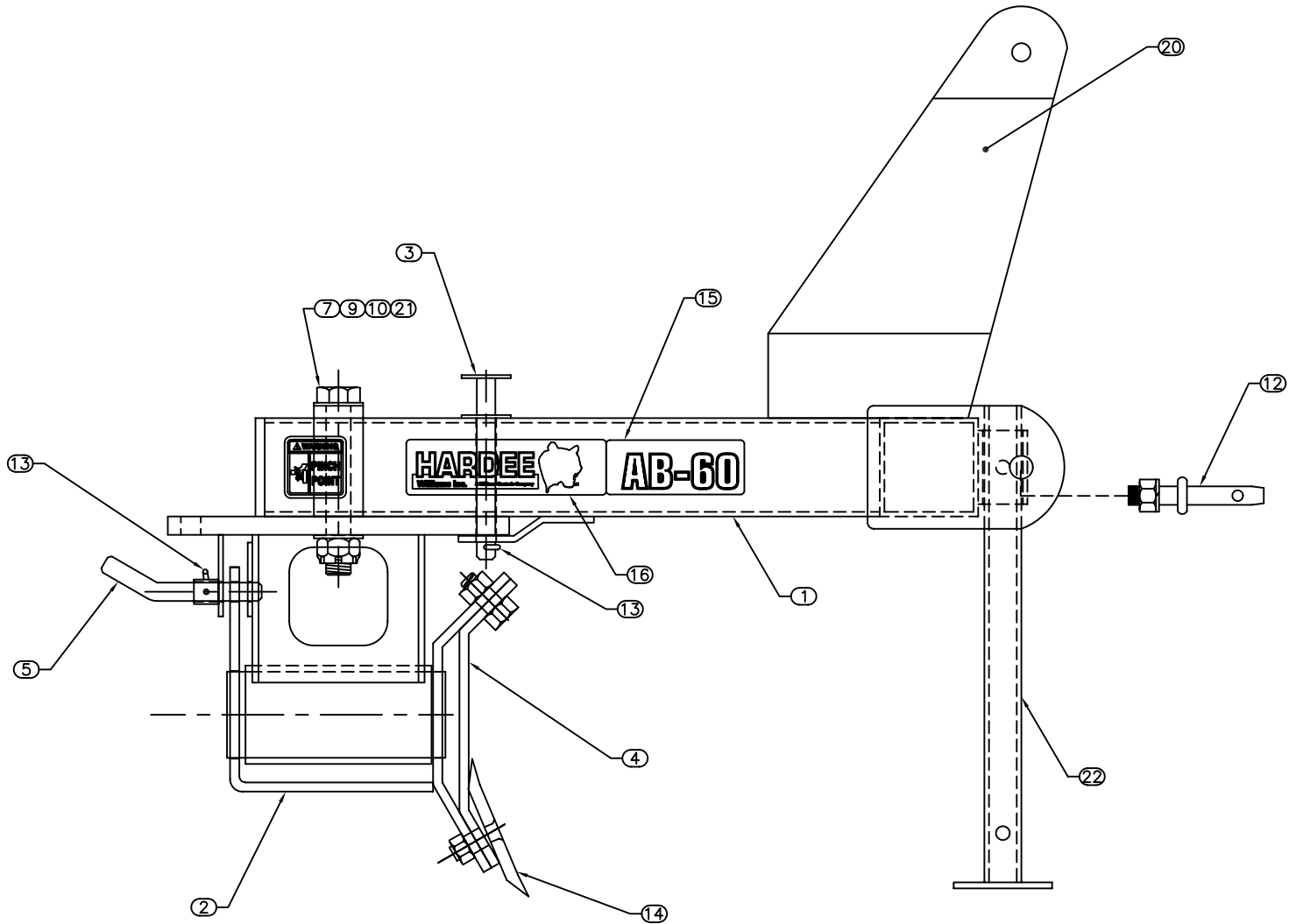

All Dimensions in Inches Unless Otherwise Specified
Dimensions in [] are in Millimeters

Tolerances Unless Otherwise Specified
Fractional Dimensions $\pm 1/16"$ Angular Dimensions $\pm 1^\circ$
Decimal Dim. to Limits Shown All holes to be $\begin{matrix} +0 \\ -1/32 \end{matrix}$

DRAWN BY	M.J.T	12/8/98
CHECKED BY		

MATERIAL R.M.N.
MANUFACTURED BY:
HARDEE MFG. CO., LLC

**HARDEE BY
EVH MFG. CO.
LORIS S.C.**

APPLICATION	OLD PART #
AB60	
DESCRIPTION AB60 REAR BLADE ASSEMBLY	
DO NOT SCALE	DWG. NO.
A	40001
DWG SIZE	SHT. 2 OF 4

**ADD THIS REVISION AT NEXT
DRAWING CHANGE**

See ECR Change #0980 for Details
Add Qty. (1) Each 15852, 15853

DWG. NO. 40001			REV. G	
REV	CHANGE	BY	DATE	ECN
C	B.O.M. CHANGES	M.J.T	10/20/98	?
D	PARTS LIST CHANGES	M.J.T	12/8/98	0538
E	ADD STAND AND DECAL SHEET	M.J.T	5/13/99	0608
F	ADD LOGO AND MODEL DECALS	M.J.T	7/28/99	0649
G	CHANGE SERIAL # PLATE	T.R.M.	6/8/00	0792

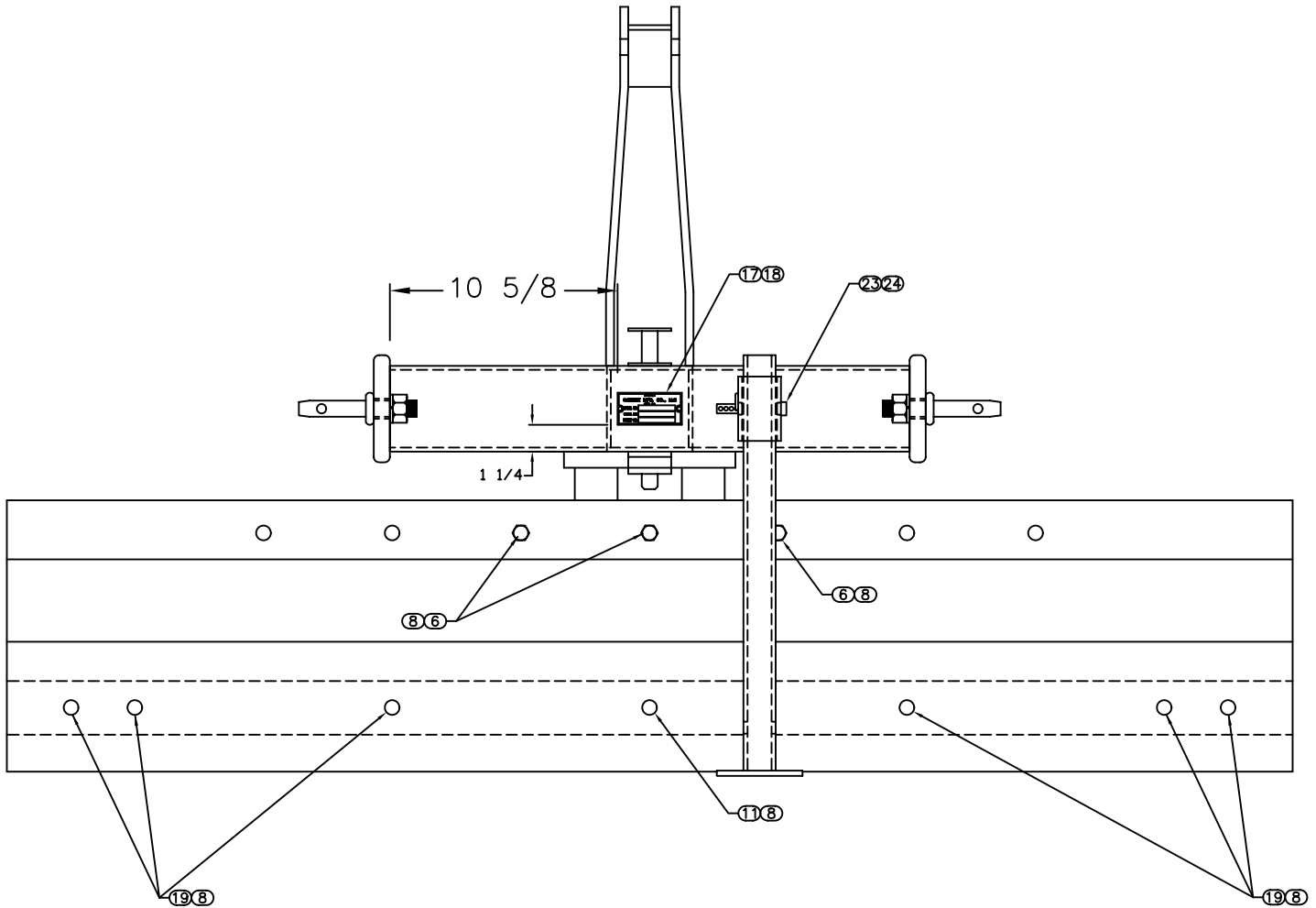

All Dimensions in Inches Unless Otherwise Specified
Dimensions in [] are in Millimeters

Tolerances Unless Otherwise Specified
Fractional Dimensions $\pm 1/16"$ Angular Dimensions $\pm 1^\circ$
Decimal Dim. to Limits Shown All holes to be $^{+0}_{-1/32}$

DRAWN BY	M.J.T	12/8/98	HARDEE BY EVH MFG. CO. LORIS S.C.	
CHECKED BY			APPLICATION	OLD PART #
MATERIAL	R.M.N.		AB60	
MANUFACTURED BY: HARDEE MFG. CO., LLC			DESCRIPTION AB60 REAR BLADE ASSEMBLY	
DO NOT SCALE	A	DWG. NO.	SHT. 3 OF 4 40001	

DWG. NO.

40001

REV.

G

ADD THIS REVISION AT NEXT DRAWING CHANGE
See ECR Change #0980 for Details
Add Qty. (1) Each 15852, 15853

REV	CHANGE	BY	DATE	ECN
C	B.O.M. CHANGES	M.J.T.	10/20/98	?
D	PARTS LIST CHANGES	M.J.T.	12/8/98	0536
E	ADD STAND AND DECAL SHEET	M.J.T.	5/12/99	0608
F	ADD MODEL AND LOGO DECALS	M.J.T.	7/28/99	0649
G	CHANGE SERIAL # PLATE	T.R.M.	6/8/00	0792

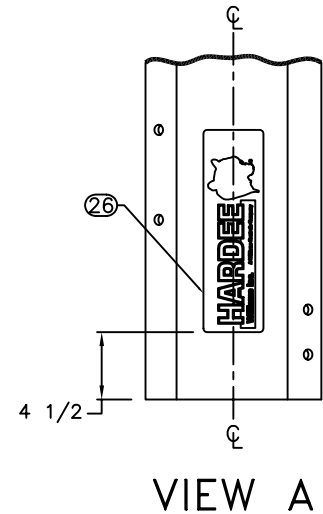
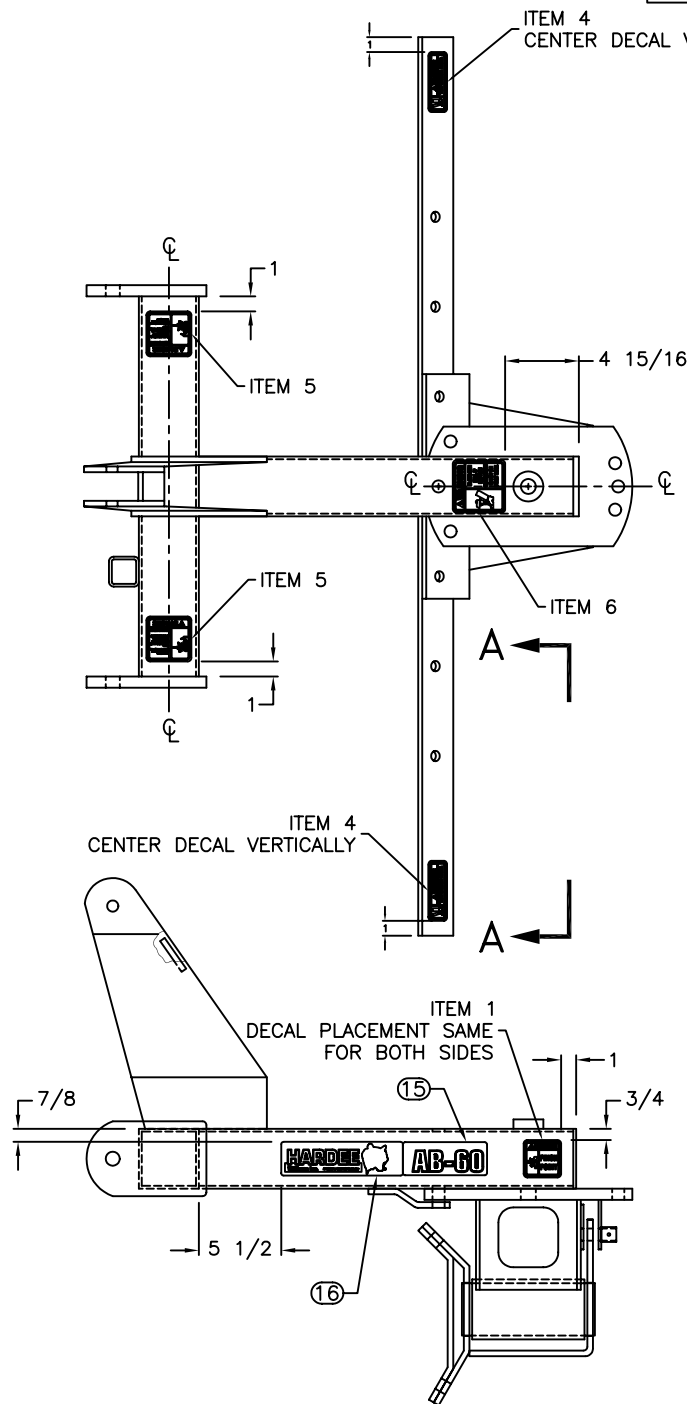

ITEM 25	
DECAL USAGE CHART	
QTY REQD.	NOMENCLATURE OR DESCRIPTION
2	ITEM 1
2	ITEM 4
2	ITEM 5
1	ITEM 6

NOTES:

1. ALL DECALS MAKE UP ITEM 25.
2. ALL PURCHASED PARTS REMOVED FOR CLARITY.

All Dimensions in Inches Unless Otherwise Specified
Dimensions in [] are in Millimeters

Tolerances Unless Otherwise Specified
Fractional Dimensions $\pm 1/16"$ Angular Dimensions $\pm 1^\circ$
Decimal Dim. to Limits Shown All holes to be $\begin{matrix} +0 \\ -1/32 \end{matrix}$

DRAWN BY	M.J.T.	5/12/99
CHECKED BY		
MATERIAL	R.M.N.	
MANUFACTURED BY: HARDEE MFG. CO., LLC		

**HARDEE BY
EVH MFG. CO.
LORIS S.C.**

APPLICATION	OLD PART #
AB60	----
DESCRIPTION AB60 REAR BLADE ASSEMBLY	
DO NOT SCALE	DWG. NO.
A	40001
DWG SIZE	SHT. 4 OF 4