

ITEM NO.	PART NUMBER	QTY REQD.	NOMENCLATURE OR DESCRIPTION
1	10019	2	HEX BOLT (5/16" x 2")
2	10031	8	HEX BOLT (3/8" x 1")
3	10073	17	HEX BOLT (1/2" x 2")
4	10097	4	HEX BOLT (5/8" x 4 1/2")
5	10116	2	HEX BOLT (3/4" x 4 1/2")
6	10166	4	LOCKNUT (5/8" PLATED)
7	10167	2	HEX NUT (3/4" PLATED)
8	10168	2	LOCKNUT (3/4" PLATED)
9	10176	17	LOCKNUT (1/2" PLATED)
10	10182	8	LOCKWASHER (3/8" PLATED)
11	11727	1	SERIAL # PLATE
12	10339	2	RIVETS FOR SERIAL # PLATE
13	10469	2	CAT. 1 HITCH PIN W/ CLIP
14	10473	2	1" 4 BOLT FLANGE W/ BEARING
15	10474	2	TENSION SPRING
16	10335	1 GAL.	RED PAINT
17	11032	2	LOGO DECAL (4" x 12")
18	11118	2	AP48 MODEL NUMBER DECAL
19	40096	1	AP48 MAIN FRAME WELDMENT
20	11636	1	SAFETY DECAL SHEET
21	40097	1	5" ROLLER WELDMENT
22	40099	1	RIGHT ROLLER ARM WELDMENT
23	40100	1	LEFT ROLLER ARM WELDMENT
24	40101	2	TENSION BAR WELDMENT
25	40115	21	CUTTING TOOTH
26	40124	2	TENSION ROD (THREADED)
27	11850	1	WEB DECAL
28	15852	2	RED REFLECTOR DECAL

DWG. NO.			REV.	
40090			D	
REV	CHANGE	BY	DATE	ECN
IR	INITIAL RELEASE	M.J.T.	12/23/97	---
A	REV TO MATCH B.O.M.	T.R.M.	12/14/99	0522
B	REV TO MATCH B.O.M.	T.R.M.	12/14/99	0586
C	UPDATE PARTS TO MATCH B.O.M.	T.O.B.	4/13/00	0764
D	CHANGE SERIAL # PLATE	T.R.M.	6/8/00	0792

ADD THIS REVISION AT NEXT DRAWING CHANGE

See ECR Change #0980 for Details
Add Qty. (1) Each 15852, 15853

All Dimensions in Inches Unless Otherwise Specified
Dimensions in [] are in Millimeters

Tolerances Unless Otherwise Specified
Fractional Dimensions ±1/16" Angular Dimensions ±1°
Decimal Dim. to Limits Shown All holes to be ⁺⁰/_{-1/32}

DRAWN BY	T.O.B.	4/13/00	HARDEE BY EVH MFG. CO. LORIS S.C.	
CHECKED BY			APPLICATION AP-48	OLD PART # N/A
MATERIAL	R.M.N. N/A		DESCRIPTION AP-48 PULVERIZER COMPLETE	
MANUFACTURED BY: HARDEE MFG. CO., LLC		DO NOT SCALE	A DWG SIZE	DWG. NO. SHT. 1 OF 4 40090

**ADD THIS REVISION AT NEXT
DRAWING CHANGE**

See ECR Change #0980 for Details
Add Qty. (1) Each 15852, 15853

DWG. NO. 40090			REV. D	
REV	CHANGE	BY	DATE	ECN
IR	INITIAL RELEASE	M.J.T	12/23/97	---
A	UP REV LEVEL TO MATCH B.O.M.	T.R.M.	12/14/99	0522
B	UP REV LEVEL TO MATCH B.O.M.	T.R.M.	12/14/99	0586
C	UPDATE PARTS TO MATCH B.O.M.	T.O.B.	4/13/00	0764
D	CHANGE SERIAL # PLATE	T.R.M.	6/8/00	0792

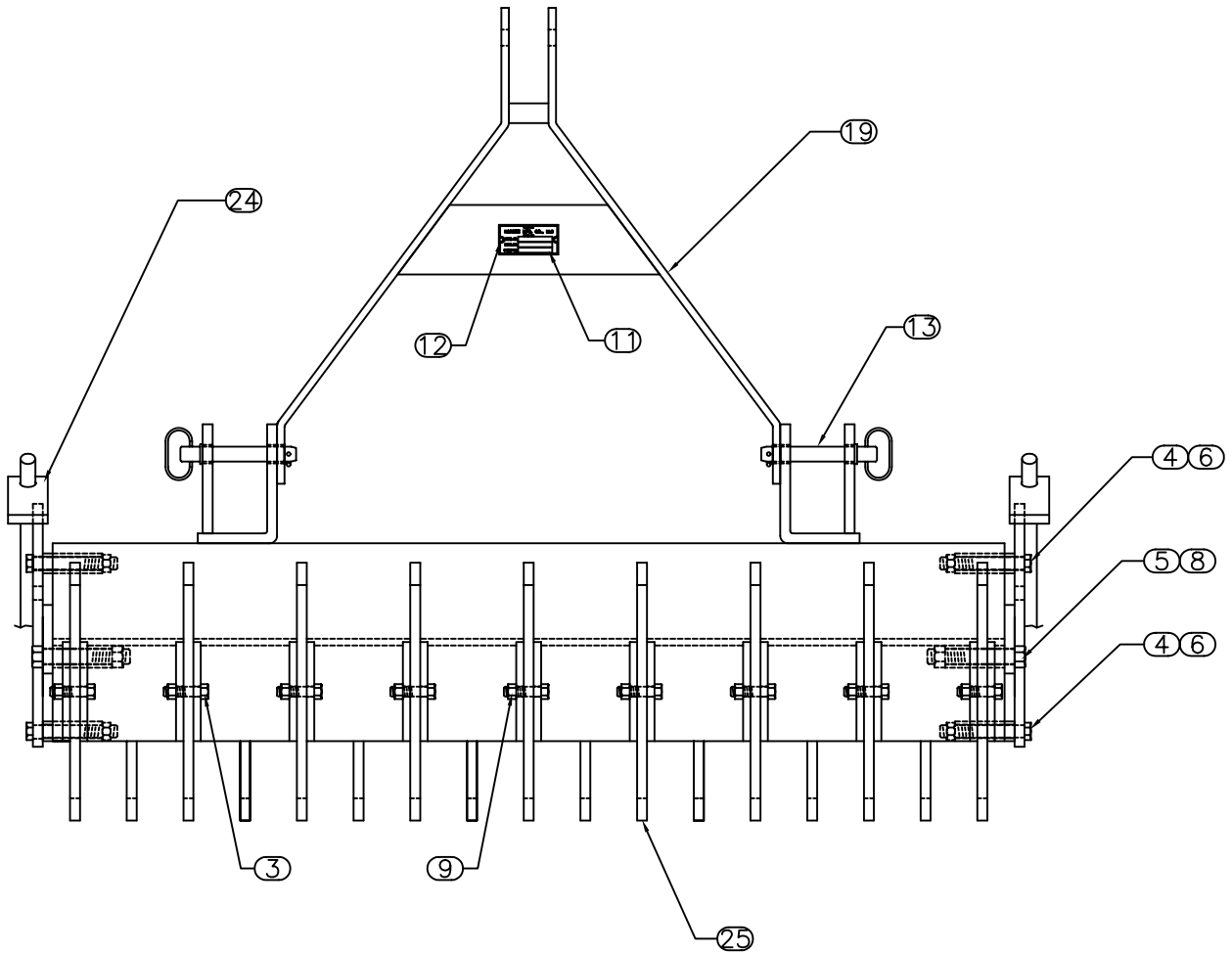

All Dimensions in Inches Unless Otherwise Specified
Dimensions in [] are in Millimeters

Tolerances Unless Otherwise Specified
Fractional Dimensions $\pm 1/16"$ Angular Dimensions $\pm 1^\circ$
Decimal Dim. to Limits Shown All holes to be $\begin{matrix} +0 \\ -1/32 \end{matrix}$

DRAWN BY	M.J.T	12/23/99	HARDEE BY EVH MFG. CO. LORIS S.C.	
CHECKED BY			APPLICATION	OLD PART #
MATERIAL	R.M.N.	N/A	AP-48	N/A
MANUFACTURED BY: HARDEE MFG. CO., LLC			DESCRIPTION AP-48 PULVERIZER COMPLETE	
DO NOT SCALE	A	DWG. NO.	SHEET 2 OF 4 40090	
	DWG SIZE			

DWG. NO.

40090

REV.

D

**ADD THIS REVISION AT NEXT
DRAWING CHANGE**

See ECR Change #0980 for Details
Add Qty. (1) Each 15852, 15853

REV	CHANGE	BY	DATE	ECN
IR	INITIAL RELEASE	M.J.T.	12/23/97	----
A	UP REV LEVEL TO MATCH B.O.M.	T.R.M.	12/14/99	0522
B	UP REV LEVEL TO MATCH B.O.M.	T.R.M.	12/14/99	0586
C	UPDATE PARTS TO MATCH B.O.M.	T.O.B.	4/13/00	0764
D	CHANGE SERIAL # PLATE	T.R.M.	6/8/00	0792

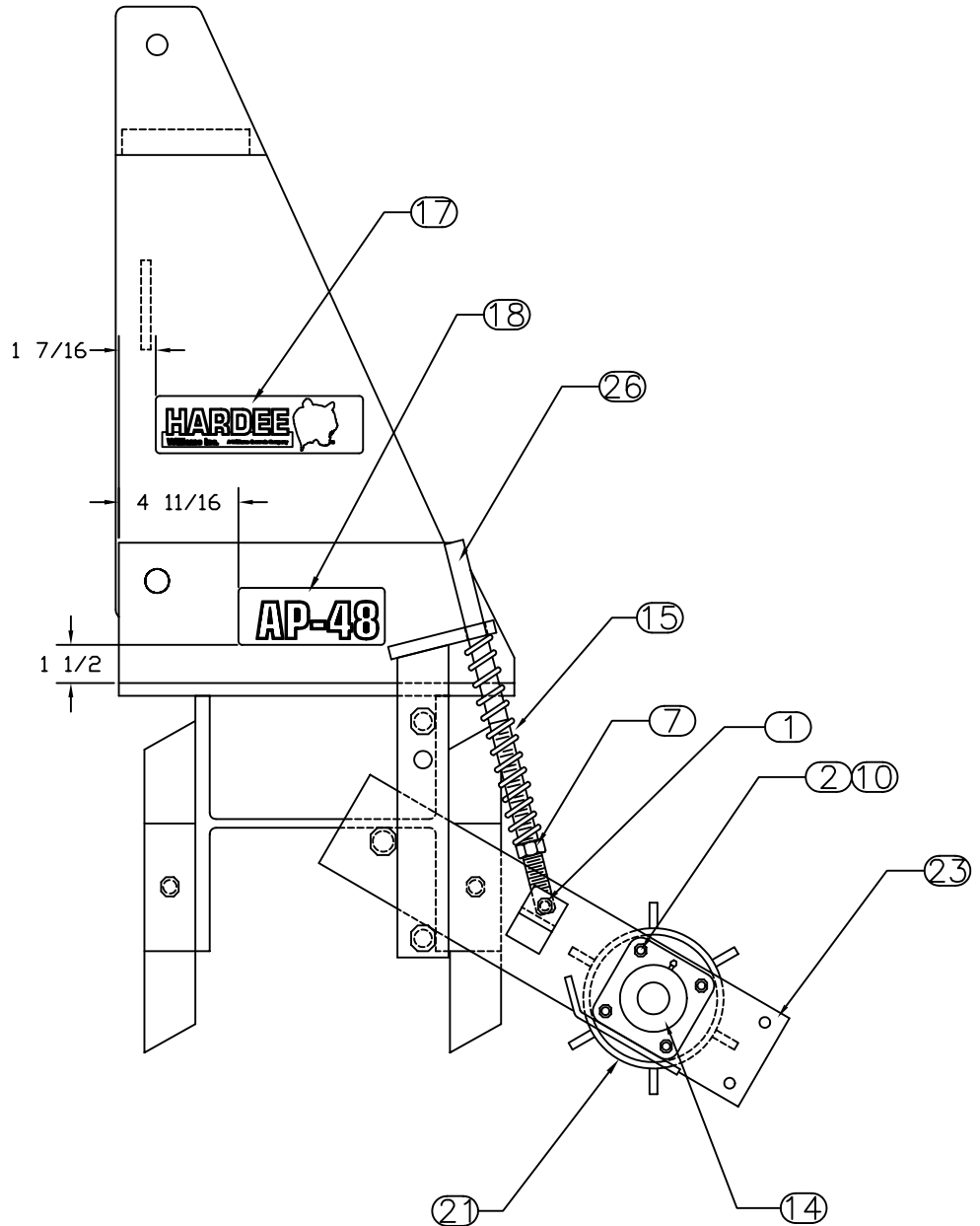

DRAWN BY	M.J.T.	6/30/99
CHECKED BY		

**HARDEE BY
EVH MFG. CO.
LORIS S.C.**

MATERIAL R.M.N.
MANUFACTURED BY:
HARDEE MFG. CO., LLC

APPLICATION	OLD PART #
AP-48	N/A
DESCRIPTION AP-48 PULVERIZER COMPLETE	
DO NOT SCALE	DWG. NO.
A	SHEET 3 OF 4 40090

All Dimensions in Inches Unless Otherwise Specified
Dimensions in [] are in Millimeters

Tolerances Unless Otherwise Specified
Fractional Dimensions $\pm 1/16"$ Angular Dimensions $\pm 1^\circ$
Decimal Dim. to Limits Shown All holes to be $\begin{matrix} +0 \\ -1/32 \end{matrix}$

ADD THIS REVISION AT NEXT DRAWING CHANGE

See ECR Change #0980 for Details
Add Qty. (1) Each 15852, 15853

DWG. NO. 40090			REV. D	
REV	CHANGE	BY	DATE	ECN
IR	INITIAL RELEASE	M.J.T.	12/23/97	----
A	UP REV LEVEL TO MATCH B.O.M.	T.R.M.	12/14/99	0522
B	UP REV LEVEL TO MATCH B.O.M.	T.R.M.	12/14/99	0586
C	UPDATE PARTS TO MATCH B.O.M.	T.O.B.	4/13/00	0764
D	CHANGE SERIAL # PLATE	T.R.M.	6/8/00	0792

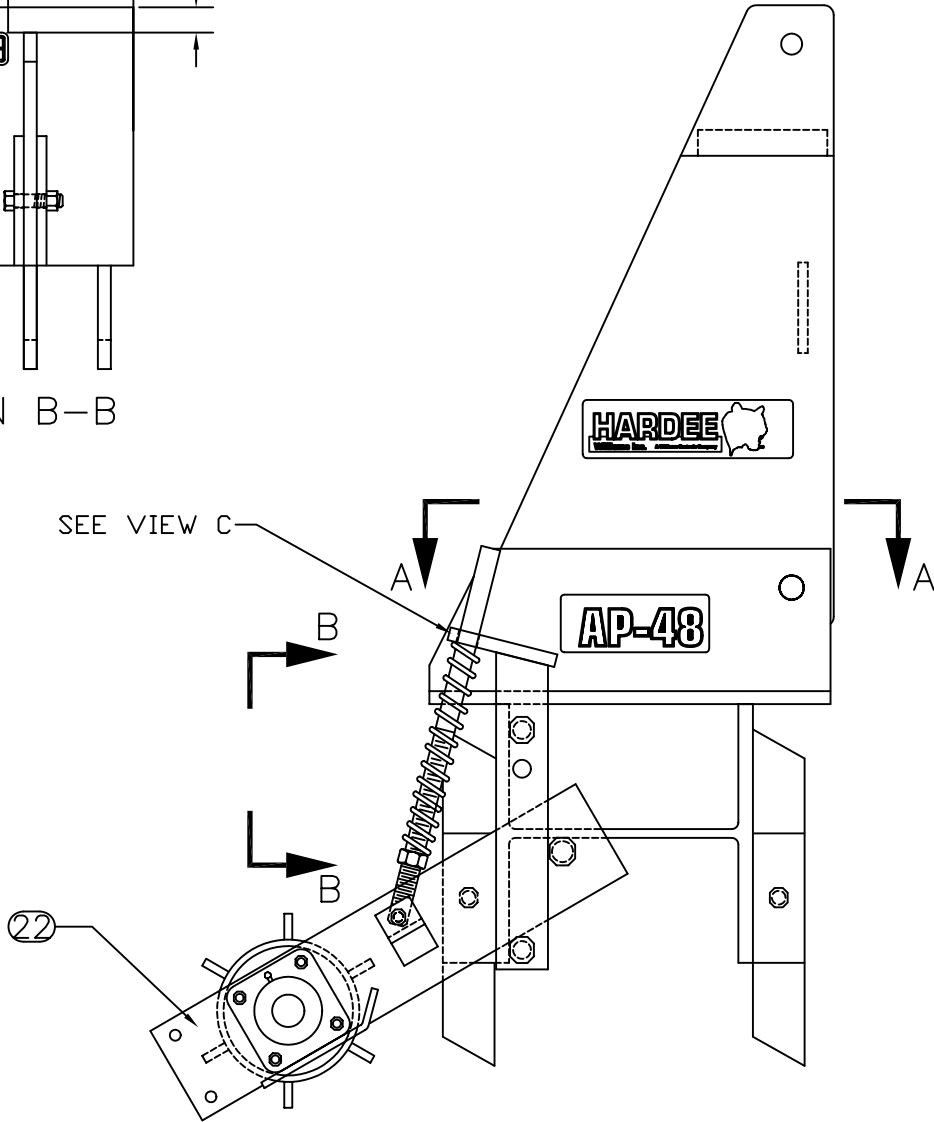
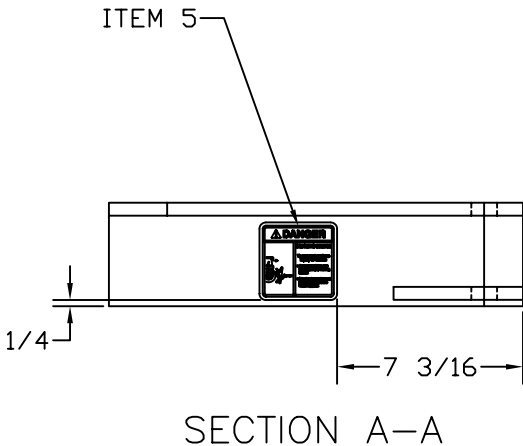
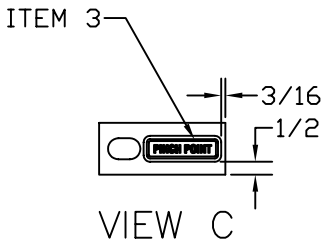
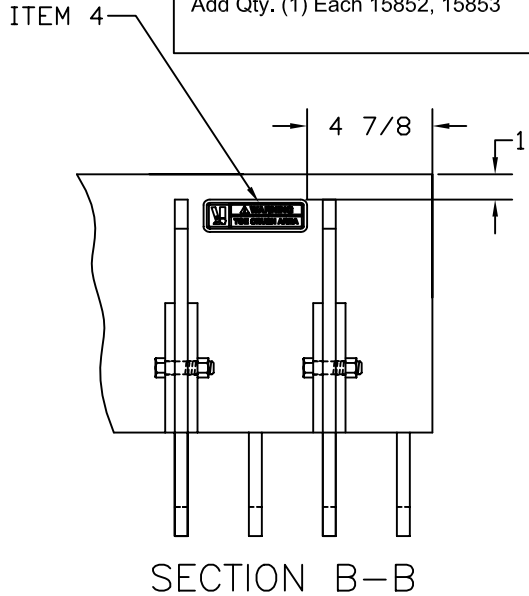

ITEM 20	
DECAL USAGE CHART	
QTY REQD.	NOMENCLATURE OR DESCRIPTION
2	ITEM 3
2	ITEM 4
2	ITEM 5

DRAWN BY	M.J.T.	6/30/99	HARDEE BY EVH MFG. CO. LORIS S.C.	
CHECKED BY				
MATERIAL	R.M.N.		APPLICATION	OLD PART #
MANUFACTURED BY: HARDEE MFG. CO., LLC			AP-48	N/A
			DESCRIPTION AP-48 PULVERIZER COMPLETE	
DO NOT SCALE	A	DWG. NO.	SHEET 4 OF 4 40090	
	DWG SIZE			

All Dimensions in Inches Unless Otherwise Specified
Dimensions in [] are in Millimeters

Tolerances Unless Otherwise Specified
Fractional Dimensions $\pm 1/16"$ Angular Dimensions $\pm 1^\circ$
Decimal Dim. to Limits Shown All holes to be $+0$
 $-1/32$