

Item	Part Number	Qty.	Description
1	10005	2	HEX BOLT, 1/4" X 2-1/2" Gr.5 Plated
2	10032	8	HEX BOLT, 3/8 x 1-1/2 Gr.5 PLATED
3	10073	25	HEX BOLT, 1/2 x 2 Gr.5 Plated
4	10097	4	HEX BOLT, 5/8-11 x 4-1/2" Gr.5 Plated
5	10116	2	HEX BOLT, 3/4 x 4-1/2 Gr.5 Plated
6	10153	2	LOCKNUT, 1/4" PLATED
7	10166	4	LOCKNUT, 5/8"-11 PLATED
8	10167	2	HEX NUT, 3/4" (Gr.5 PLATED)
9	10168	2	LOCKNUT, 3/4"-10 (Gr.5 Plated)
10	10175	8	LOCKNUT, 3/8"-16 Gr.5 PLATED
11	10176	25	LOCKNUT, 1/2" (Gr.5 Plated)
12	10339	2	POP RIVET
13	10469	2	HITCH PIN (4-1/4" CAT. 1)
14	10473	2	4 BOLT FLANGED BEARING
15	10474	2	SPRING, COMPRESSION, 1-1/8 DIA. X 9
16	11032	2	DECAL, SMALL HARDEE LOGO
17	11120	2	AP-72 DECAL
18	11636-3	2	WARNING DECAL (KIT 11636)
19	11636-4	2	WARNING DECAL (KIT 11636)
20	11636-5	2	DANGER DECAL (KIT 11636)
21	11727	1	SERIAL NUMBER PLATE
22	15852	2	RED REFLECTOR DECAL
23	15853	2	YELLOW REFLECTOR DECAL
24	40099	1	ROLLER ARM WELDMENT, RIGHT
25	40100	1	ROLLER ARM WELDMENT, LEFT
26	40101	2	TENSION BAR WELDMENT
27	40115	25	CUTTING TOOTH FOR PULVERIZER
28	40124	2	TENSION ROD (THREADED)
29	40261	1	MAIN FRAME WELDMENT, AP72
30	40265	1	ROLLER WELDMENT, AP72

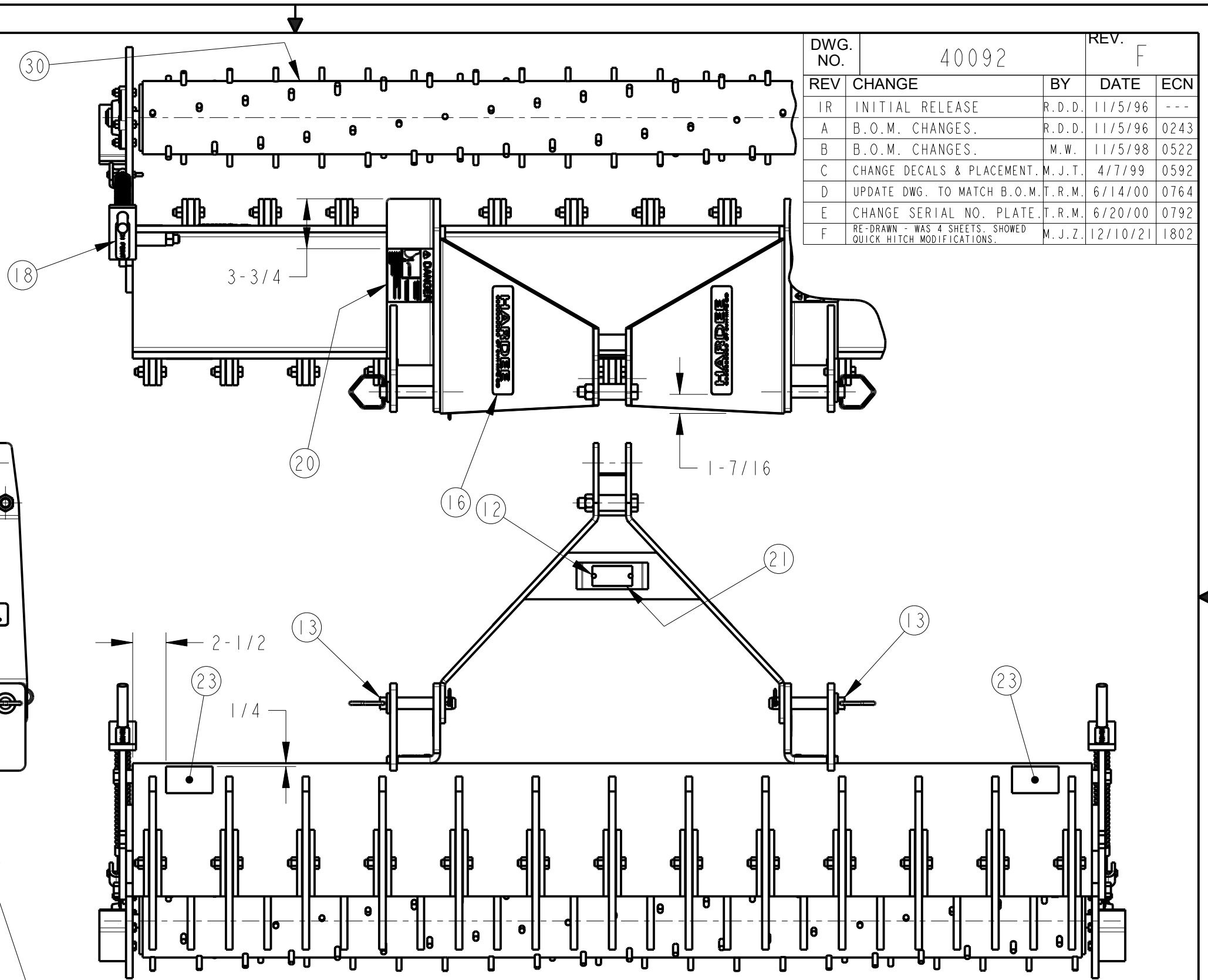
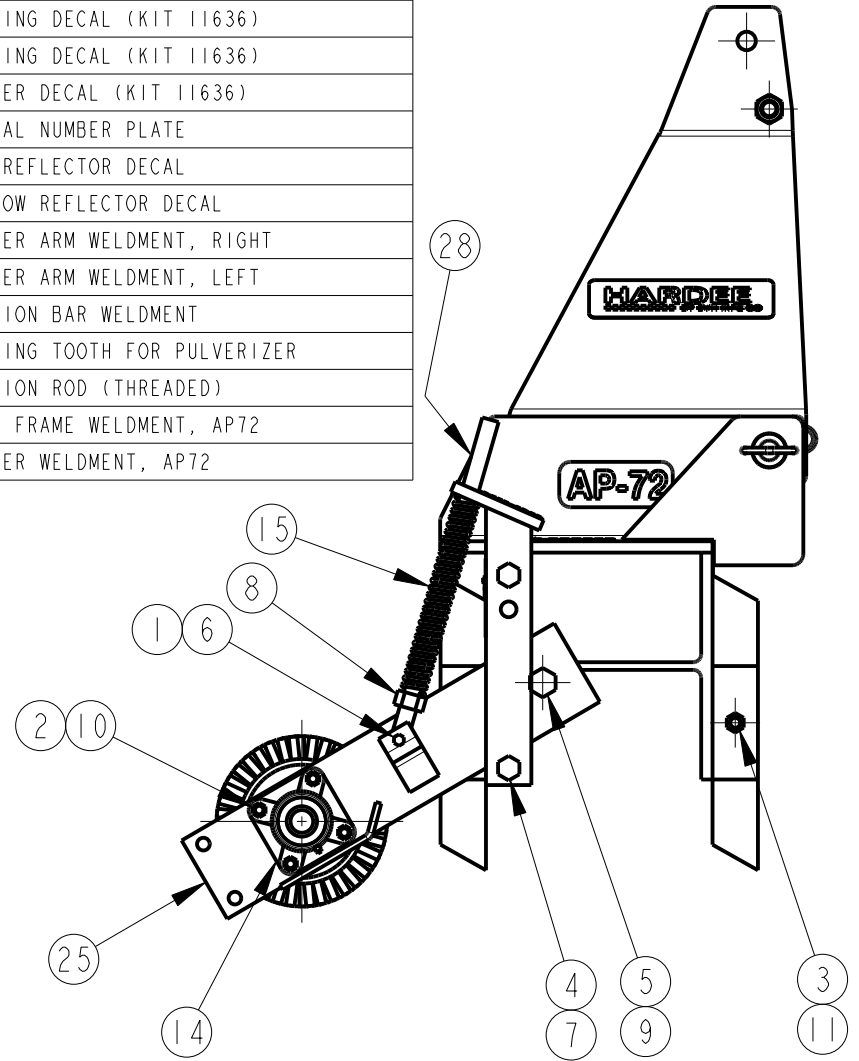

DWG. NO.	40092		REV.	F	
REV	CHANGE	BY	DATE	ECN	
IR	INITIAL RELEASE	R.D.D.	11/5/96	---	
A	B.O.M. CHANGES.	R.D.D.	11/5/96	0243	
B	B.O.M. CHANGES.	M.W.	11/5/98	0522	
C	CHANGE DECALS & PLACEMENT.	M.J.T.	4/7/99	0592	
D	UPDATE DWG. TO MATCH B.O.M.	T.R.M.	6/14/00	0764	
E	CHANGE SERIAL NO. PLATE.	T.R.M.	6/20/00	0792	
F	RE-DRAWN - WAS 4 SHEETS. SHOWED QUICK HITCH MODIFICATIONS.	M.J.Z.	12/10/21	1802	

All Dimensions in Inches Unless Otherwise Specified  
Dimensions in [ ] are in Millimeters  
Tolerance Unless Otherwise Specified  
Fractional Dimensions: 1/16" Angular Dimensions: 1°  
Decimal Dim. to Limits Shown All Holes to be +0 -1/32"

MODELED BY	M. J. Z.	11/19/21	<b>HARDEE BY EVH MFG. CO. LORIS S.C.</b>	
CHECKED BY	C. K. N.	12/6/21		
MATERIAL	R.M.N.	N/A	DESCRIPTION	SHEET 1 of 2
Manufactured By: EVH Mfg. Co., LLC			AP-72 REAR PULVERIZER	
DO NOT SCALE	B	DWG. NO.	40092	

DWG. NO.	40092			REV.	F
REV	CHANGE	BY	DATE	ECN	
IR	INITIAL RELEASE	R.D.D.	11/5/96	---	
A	B.O.M. CHANGES.	R.D.D.	11/5/96	0243	
B	B.O.M. CHANGES.	M.W.	11/5/98	0522	
C	CHANGE DECALS & PLACEMENT.	M.J.T.	4/7/99	0592	
D	UPDATE DWG. TO MATCH B.O.M.	T.R.M.	6/14/00	0764	
E	CHANGE SERIAL NO. PLATE.	T.R.M.	6/20/00	0792	
F	RE-DRAWN - WAS 4 SHEETS. SHOWED QUICK HITCH MODIFICATIONS.	M.J.Z.	12/10/21	1802	

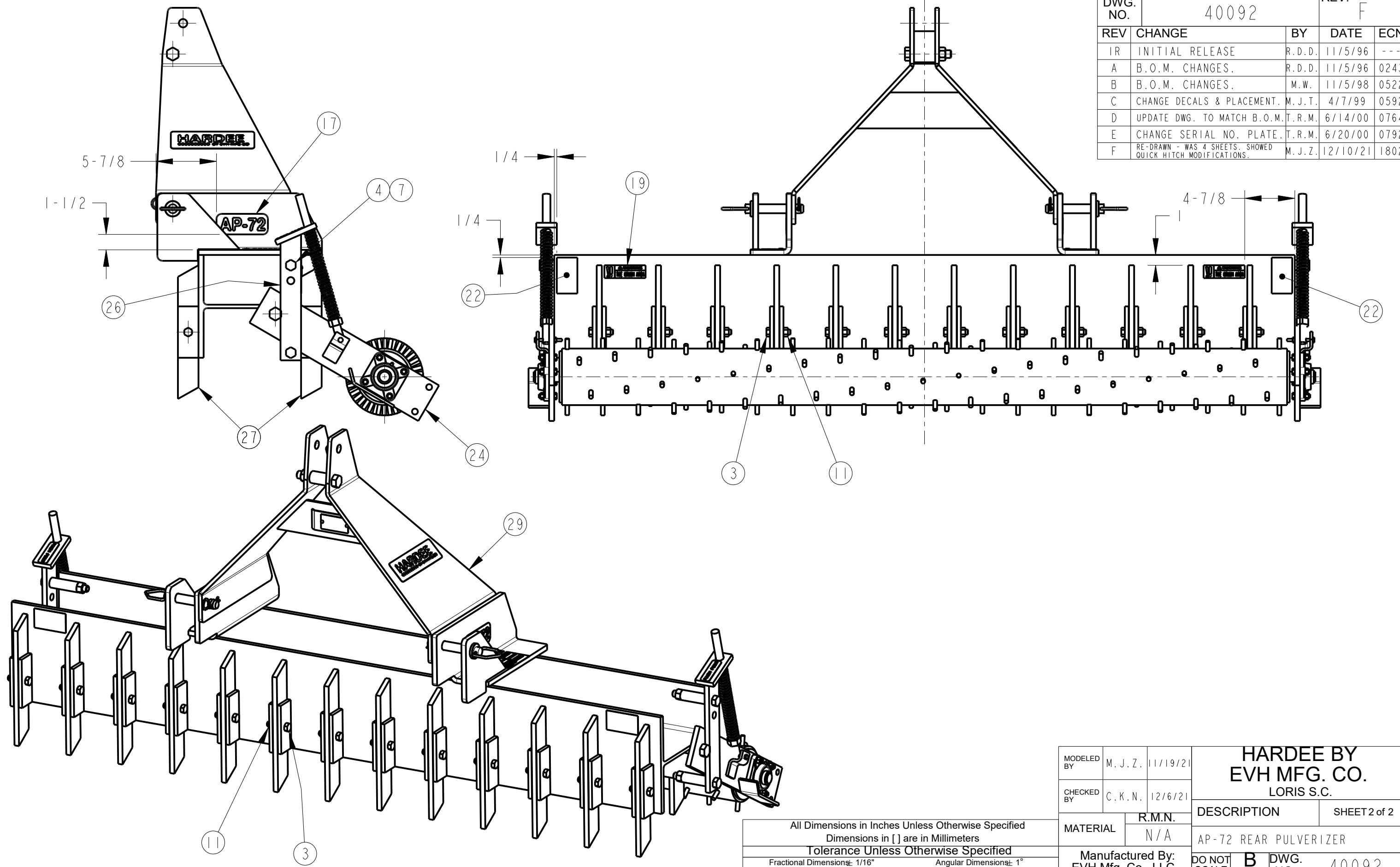

All Dimensions in Inches Unless Otherwise Specified  
 Dimensions in [ ] are in Millimeters  
 Tolerance Unless Otherwise Specified  
 Fractional Dimensions: 1/16"  
 Decimal Dim. to Limits Shown  
 Angular Dimensions: 1°  
 All Holes to be +0 -1/32"

MODELED BY	M. J. Z.	11/19/21	<b>HARDEE BY EVH MFG. CO. LORIS S.C.</b>	
CHECKED BY	C. K. N.	12/6/21		
MATERIAL	R.M.N.	N/A	DESCRIPTION	SHEET 2 of 2
Manufactured By: EVH Mfg. Co., LLC			AP-72 REAR PULVERIZER	
DO NOT SCALE	B	DWG. NO.	40092	
	DWG. SIZE			