

ITEM NO.	PART NUMBER	QTY REQD.	NOMENCLATURE OR DESCRIPTION
1	20031	1	ACCESS COVER
2	20035	1	FLOATING LINKAGE WELDMENT
3	24215	1	FLOATING LINKAGE SPACER
4	20194	1	A-FRAME SUPPORT SPACER
5	20488	2	A-FRAME WELDMENT
6	20491	2	FLAT STRUT
7	20497	2	T/W FORK & ARM ASSEMBLY
8	20298	1	BLADE HOLDER COMPLETE
9	20247	2	BOLT-ON SLIDE
10	11850	1	WEB DECAL
11	20813	1	FRONT RUBBER BELTING
12	20141	1	FRONT RUBBER SHIELD FLAT
13	20818	1	REAR RUBBER BELTING
14	20819	1	REAR RUBBER SHIELD FLAT
15	10330	2	15" SOLID TIRE AND RIM
16	20195	2	T/W HUB COMPLETE
17	11727	1	SERIAL NUMBER PLATE
18	10339	2	RIVETS FOR SERIAL # PLATE
19	10327	1	90 HP OMNI GEARBOX
20	10475	1	GEAR BOX SHIELD W/ACCESS COVER
21	11566	1	BINACCHI DRIVESHAFT
22	11009	2	MODEL NUMBER DECAL
23	11131	2	HWI LOGO DECAL
24	11001	1	DANGER DECAL
25	11002	3	DANGER KEEP CLEAR DECAL
26	11003	1	CAUTION DECAL
27	11004	1	CAUTION DECAL
28	11005	1	WARNING DECAL
29	11006	1	SAFETY DECAL
30	10307	2	CAT. 1 HITCH PIN
31	10111	2	HEX BOLT (3/4" x 2")
32	10110	4	HEX BOLT (3/4" x 1 1/2")
33	10118	1	HEX BOLT (3/4" x 5 1/2")
34	10098	1	HEX BOLT (5/8" x 5")
35	10097	4	HEX BOLT (5/8" x 4 1/2")
36	10102	2	HEX BOLT (5/8" x 7")
37	10029	5	HEX BOLT (3/8" x 1 1/4")
38	10016	4	HEX BOLT (5/16" x 3/4")
39	10260	6	PLOW BOLT (1/2" x 1 1/2")
40	10185	8	LOCK WASHER (5/8" PLATED)

DWG. NO.			REV.	
21408			IR	
REV	CHANGE	BY	DATE	ECN
IR	INITIAL RELEASE	K.N.	7/07/08	---

41	10166	8	LOCK NUT (5/8" PLATED)
42	10168	11	LOCK NUT (3/4" PLATED)
43	10186	4	LOCK WASHER (3/4" PLATED)
44	10175	9	LOCK NUT (3/8" PLATED)
45	10202	18	FLAT WASHER (3/8" PLATED)
46	10176	6	LOCK NUT (1/2" PLATED)
47	10201	4	FLAT WASHER (5/16" PLATED)
48	10181	5	LOCK WASHER (5/16" PLATED)
49	10173	1	NUT/WASHER (1 1/4")
50	10243	1	COTTER PIN (5/32" x 2")
51	20211	1	T-1060-LT DECK WELDMENT
52	10335	.76	RED PAINT (NOT SHOWN)
53	10336	.19	GEAR OIL (NOT SHOWN)
54	10646	.13	GREASE(NOT SHOWN)
55	10894	4	24" TIE STRAP (NOT SHOWN)
56	10154	1	5/16" LOCKNUT
57	10002	2	HEX BOLT (1/4" X 3/4")
58	10200	2	FLAT WASHER (1/4")
59	15854	1	MANUAL HOLDER
60	15852	2	RED REFLECTOR
61	15853	2	YELLOW REFLECTOR
62	15860	2	U-NUT 1/4"
63	10032	4	HEX BOLT (3/8" X 1-1/2")

All Dimensions in Inches Unless Otherwise Specified  
Dimensions in [ ] are in Millimeters

Tolerances Unless Otherwise Specified  
Fractional Dimensions ±1/16" Angular Dimensions ±1°  
Decimal Dim. to Limits Shown All holes to be  $\begin{matrix} +0 \\ -1/32 \end{matrix}$

DRAWN BY	K.N.	7/07/08	<b>EVH</b> <b>MANUFACTURING CO</b> LORIS S.C.	
CHECKED BY				
MATERIAL	R.M.N.	N/A	APPLICATION	OLD PART #
MANUFACTURED BY: EVH MANUFACTURING CO			1060W	N/A
			DESCRIPTION ASSEMBLY DRAWING FOR 1060W	
DO NOT SCALE	A	DWG. NO.	SHT 1 OF 3 21408	

DWG. NO.

21408

REV.

IR

REV	CHANGE	BY	DATE	ECN
IR	INITIAL RELEASE	K.N.	7/07/08	---

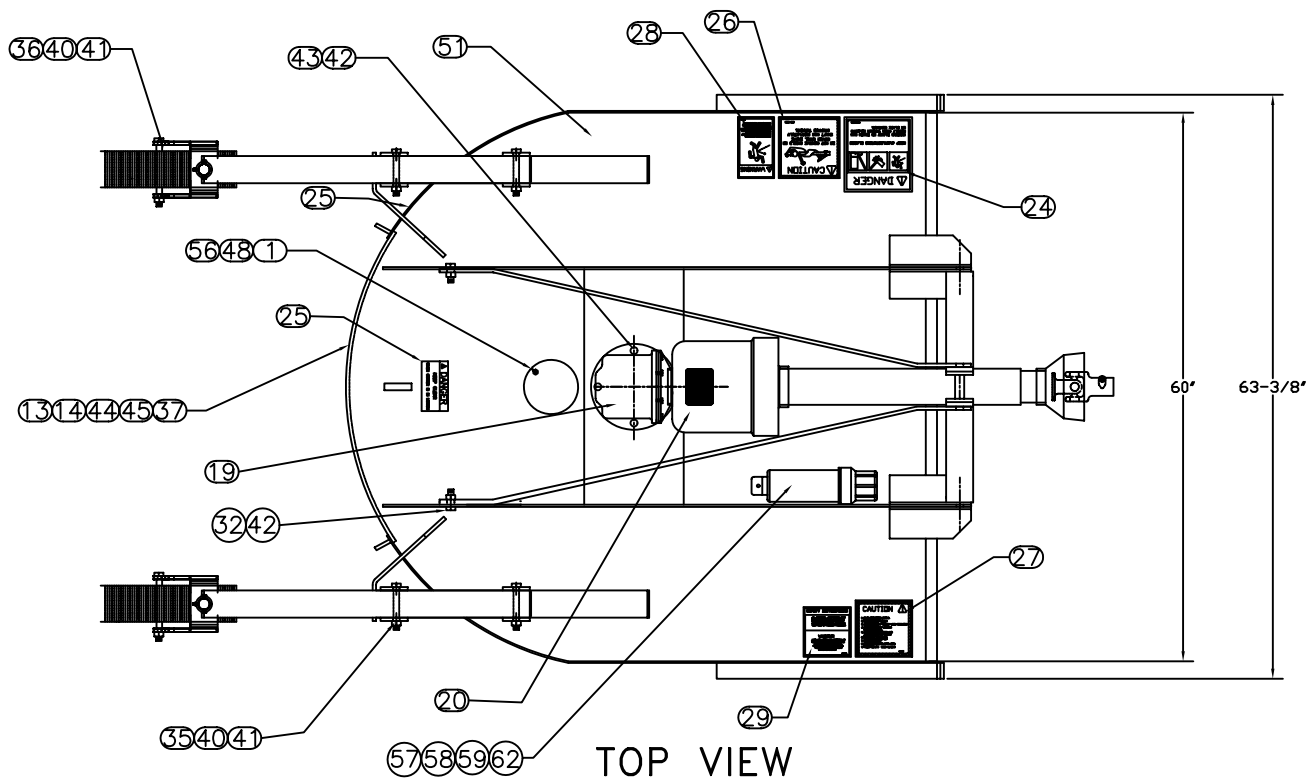

TOP VIEW

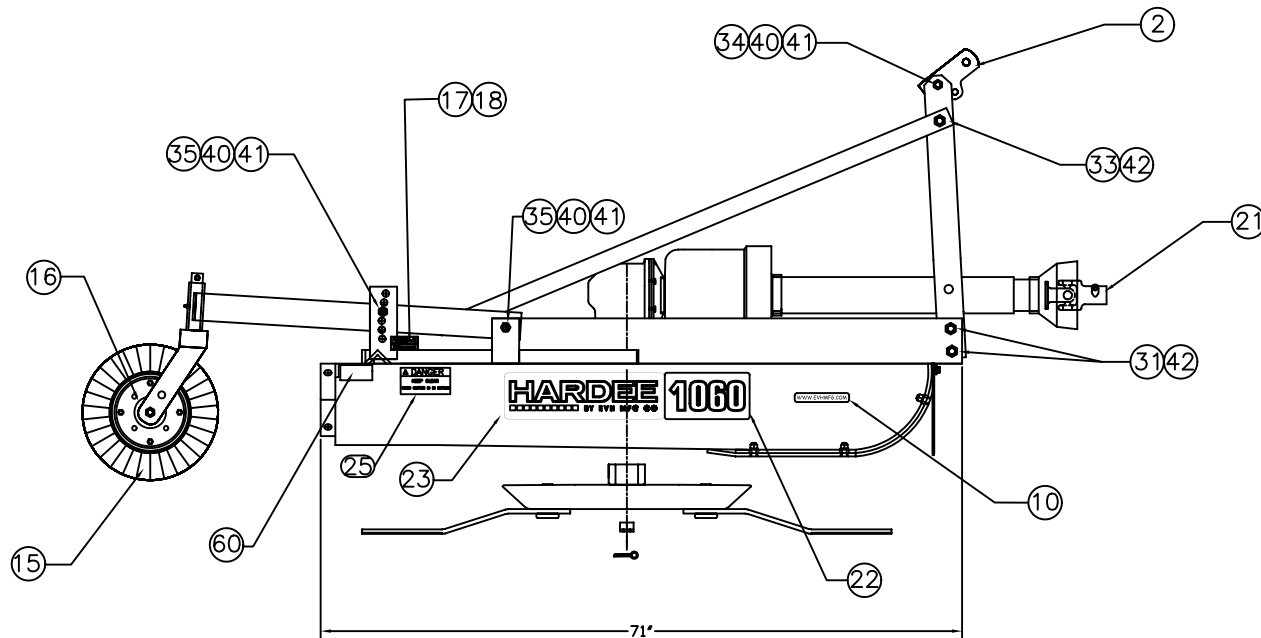

R.H. VIEW

All Dimensions in Inches Unless Otherwise Specified  
 Dimensions in [ ] are in Millimeters

Tolerances Unless Otherwise Specified  
 Fractional Dimensions  $\pm 1/16"$  Angular Dimensions  $\pm 1^\circ$   
 Decimal Dim. to Limits Shown All holes to be  $+0$   
 $-1/32$

DRAWN BY	K.N.	7/07/08
CHECKED BY		
MATERIAL	R.M.N.	
MANUFACTURED BY: EVH MANUFACTURING CO		

<b>EVH MANUFACTURING CO</b>	
LORIS S.C.	
APPLICATION 1060W	OLD PART # ----
DESCRIPTION ASSEMBLY DRAWING FOR 1060W	
DO NOT SCALE	DWG. NO. 21408
A DWG SIZE	SHT 2 OF 3

DWG. NO.

21408

REV.

IR

REV	CHANGE	BY	DATE	ECN
IR	INITIAL RELEASE	K.N.	7/07/08	---

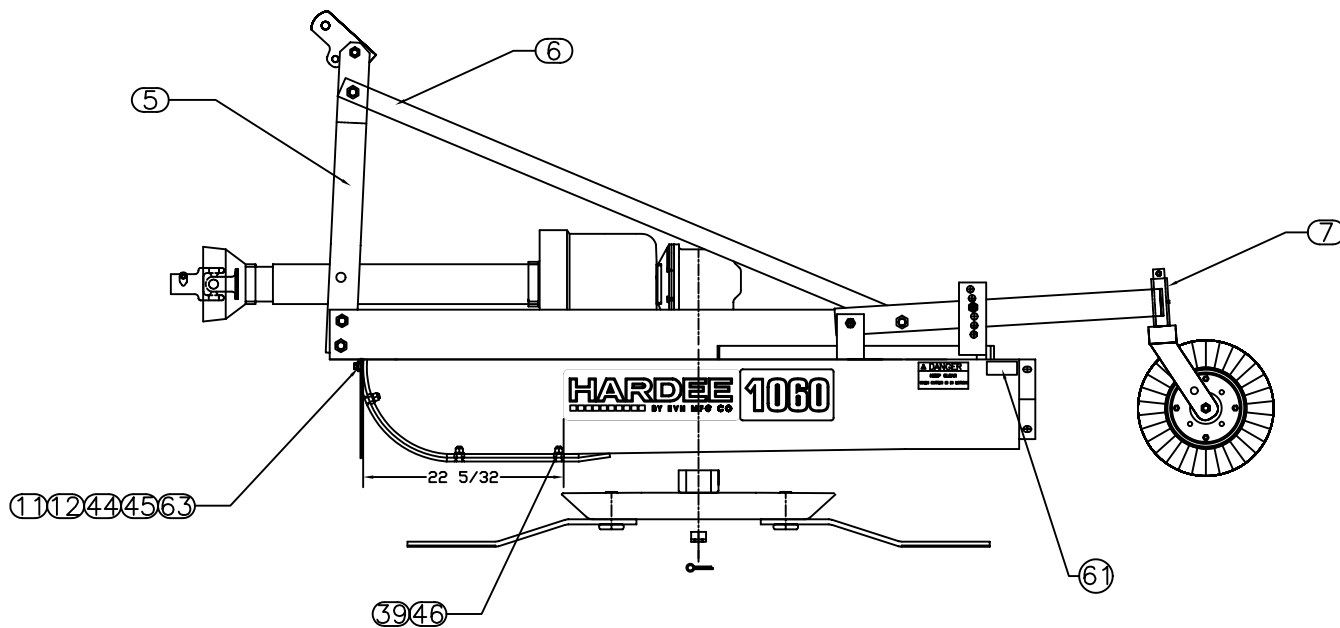

L.H. VIEW

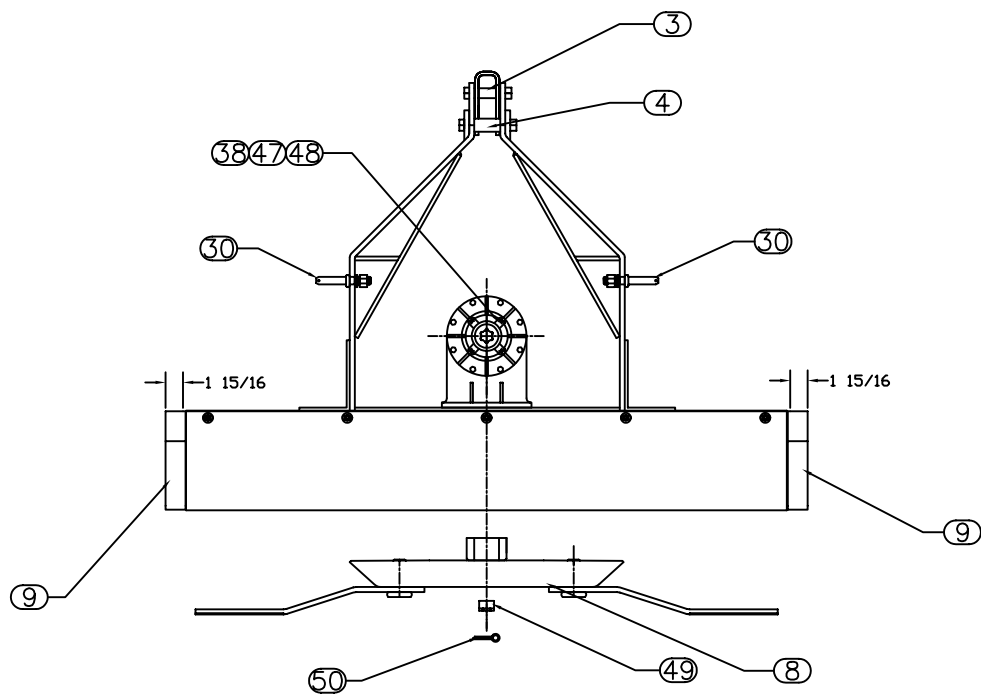

FRONT VIEW

DRAWN BY	K.N.	7/07/08	EVH MANUFACTURING CO LORIS S.C.	
CHECKED BY				
MATERIAL	R.M.N.		APPLICATION	OLD PART #
MANUFACTURED BY: EVH MANUFACTURING CO			1060W	----
			DESCRIPTION ASSEMBLY DRAWING FOR 1060W	
DO NOT SCALE	A	DWG. NO.	21408	
DWG SIZE		SHT 3 OF 3		

All Dimensions in Inches Unless Otherwise Specified  
Dimensions in [ ] are in Millimeters

Tolerances Unless Otherwise Specified  
Fractional Dimensions  $\pm 1/16"$  Angular Dimensions  $\pm 1^\circ$   
Decimal Dim. to Limits Shown All holes to be  $+0$   
 $-1/32$

ITEM NO.	PART NUMBER	QTY REQD.	NOMENCLATURE OR DESCRIPTION
1	20236	1	BLADE HOLDER WELDMENT
2	10313	2	BLADE BOLT GR.8
3	10426	2	UP LIFT BLADE
4	10311	2	BLADE BOLT NUT GR.8
5	10312	2	BLADE BOLT LOCKWASHER GR.8

DWG. NO.			REV.	
20298			B	
REV	CHANGE	BY	DATE	ECN
IR	INITIAL RELEASE	M.J.T	11/4/97	----
A	CREATE VIEWS	M.J.T	6/10/98	0381
B	CHANGE BLADE PART NUMBER	M.J.T	11/30/98	0533

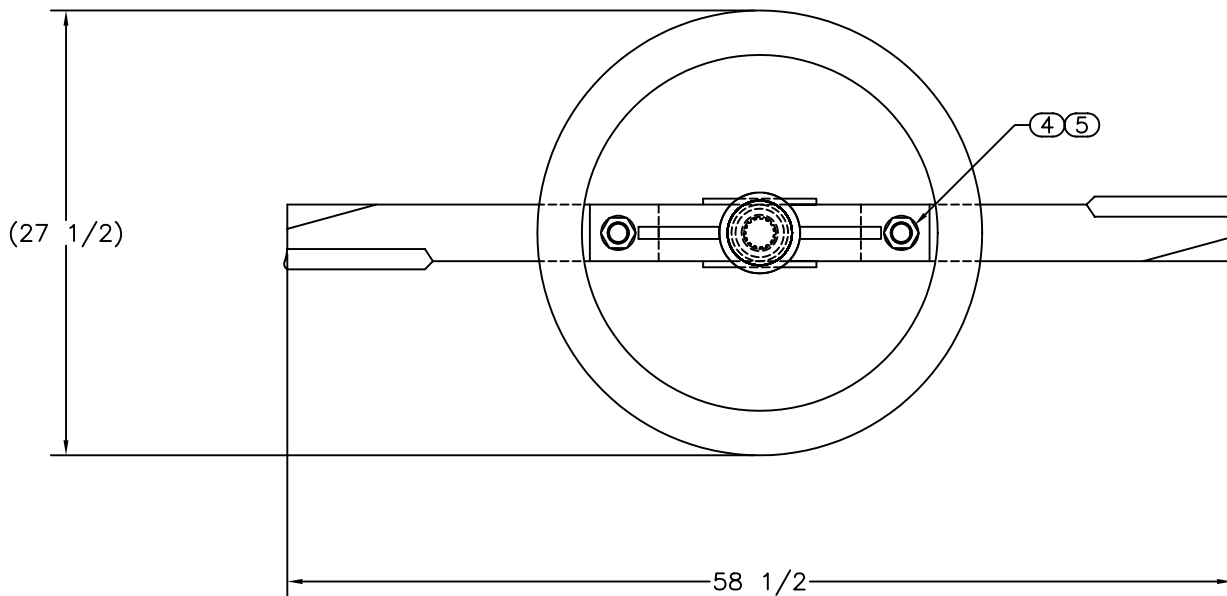
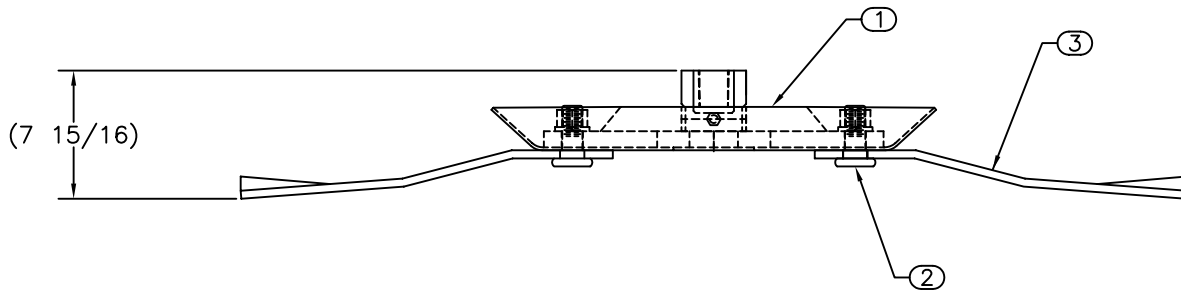

DRAWN BY	M.J.T	6/10/98
CHECKED BY		
MATERIAL	R.M.N.	
MANUFACTURED BY HARDEE WILLIAMS		

<b>HARDEE BY EVH MFG. CO. LORIS S.C.</b>	
APPLICATION	OLD PART #
DESCRIPTION BLADE HOLDER SUBASSEMBLY	
DO NOT SCALE	DWG. NO. 20298
A	DWG. SIZE

All Dimensions in Inches Unless Otherwise Specified  
Dimensions in [ ] are in Millimeters

Tolerances Unless Otherwise Specified  
Fractional Dimensions  $\pm 1/16"$  Angular Dimensions  $\pm 1^\circ$   
Decimal Dim. to Limits Shown All holes to be  $\begin{matrix} +0 \\ -1/32 \end{matrix}$

# 10327 Gearbox

( 90H.P. Gearbox 1: 1.47 Ratio)

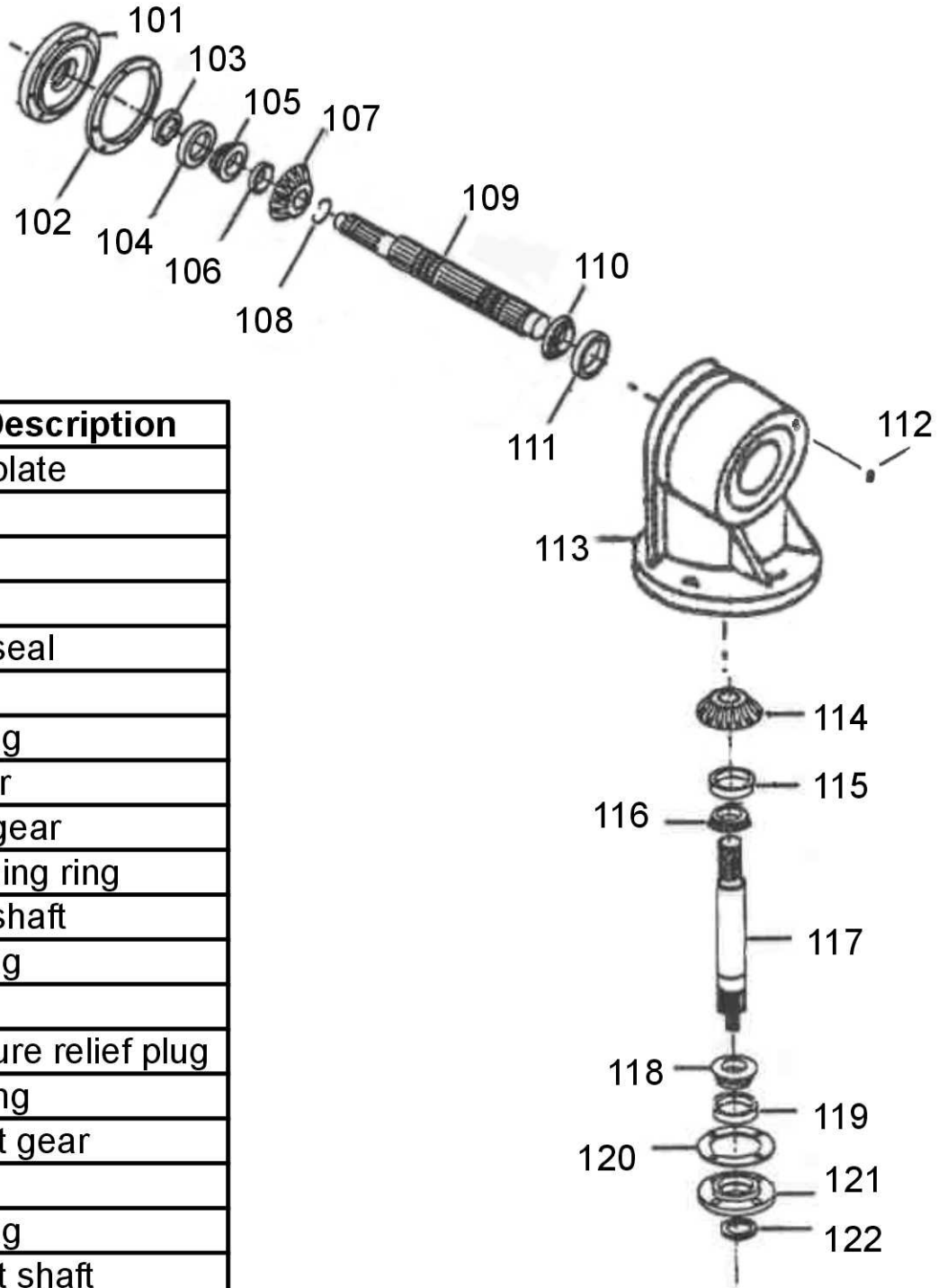

Key #	Part No.	Part Description
101	15768	Face plate
102	15732	Shim
	15733	Shim
	15734	Shim
103	15715	Input seal
104	11240	Cup
105	11241	Bearing
106	15606	Spacer
107	10683	Input gear
108	10353	Retaining ring
109	15602	Input shaft
110	11241	Bearing
111	11240	Cup
112	15664	Pressure relief plug
113	11516	Housing
114	10682	Output gear
115	11243	Cup
116	10352	Bearing
117	15600	Output shaft
118	10352	Bearing
119	11242	Cup
120	15706	Shim
121	15705	Bottom cover
122	10354	Output seal

# 11566 Driveshaft

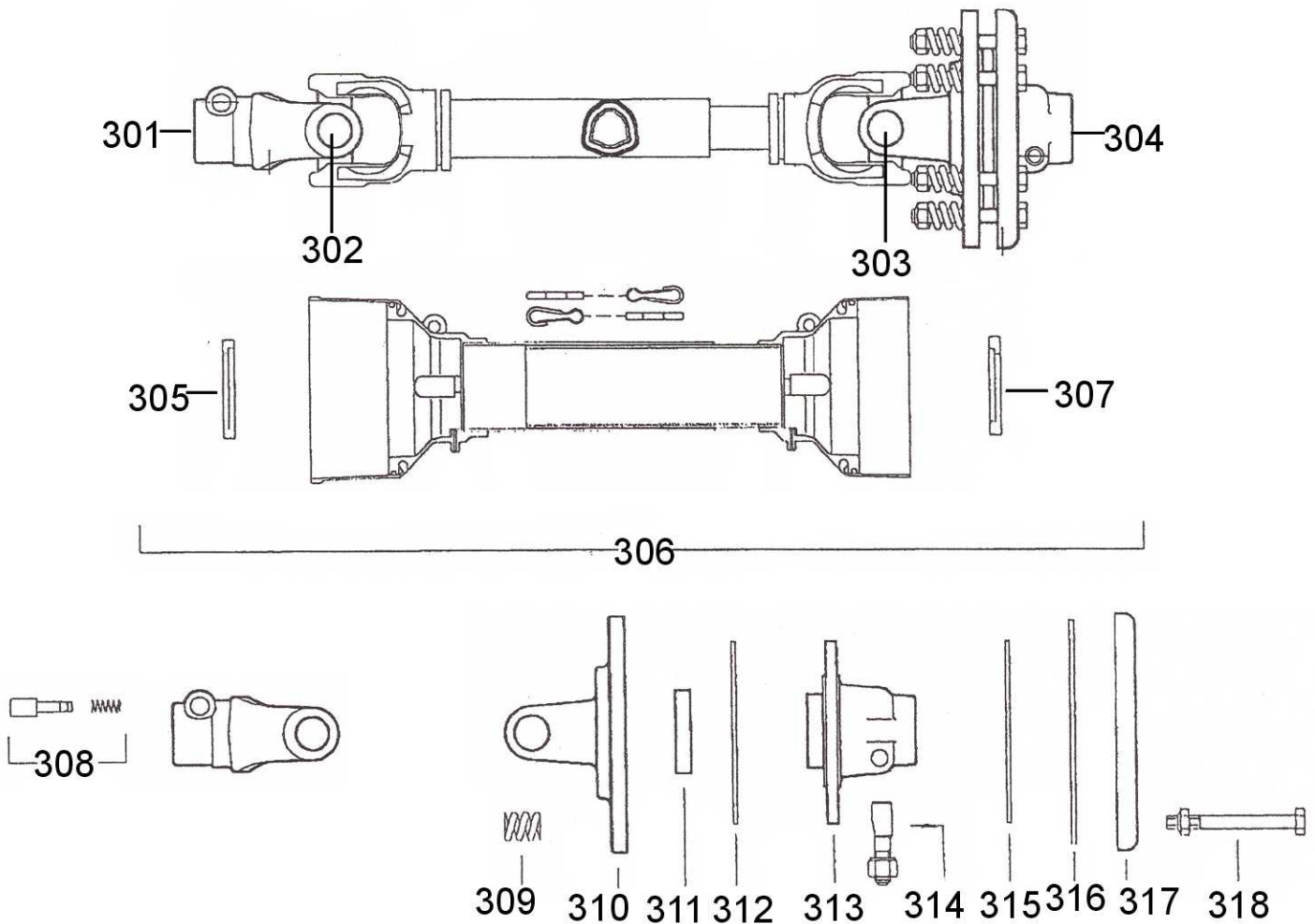

Key #	Part No.	Description	Key #	Part No.	Description
301	15658	Yoke, Tractor end	310	15798	Flange yoke
302	15629	Cross kit	311	15562	Bushing
303	15629	Cross kit	312	11204	Clutch facing
304	15630	Clutch, complete	313	15633	Center hub
305	15795	Shield bearing	314	15615	Wedge bolt
306	15797	Shield kit complete	315	11204	Clutch facing
307	15796	Shield bearing	316	15563	Inner plate
308	15579	Push pin complete	317	15799	Pressure plate
309	15561	Spring	318	15794	Clutch bolt