



OPERATOR'S AND MAINTENANCE MANUAL

Heavy-Duty Scraper Blade



DANGER
*Read this manual and the
manual for your tractor
carefully to acquaint yourself
before operating!*

ABH-96

4895 RED BLUFF RD, LORIS, SC-29569

(843) 756-2555

evhmf@hardeebyevh.com

www.hardeebyevh.com

MODEL NUMBER _____
SERIAL NUMBER _____
DATE OF PURCHASE _____

Customer Pre-Operation Check List		Reference
<input type="checkbox"/>	Read, understand and follow the general safety rules listed in this manual.	Page 2
<input type="checkbox"/>	Take note of all warning and safety decals.	Page 3-4

Table of Contents

Section 1 Introduction	1
To Our Customers	1
Owner's Responsibility	1
Purpose Of This Manual	1
Safety-Alert Symbol	1
Signal Words	1
Customer Assistance	1
Section 2	2
General Safety Rules	2
Safety Decals	3
Safety Decals Locations	4
Section 3 Operation	5
Operation Instructions	5
During Operation	5
Center Frame - Swing	5
Rear Blade - Pivot	5
Rear Blade - Tilt	5
Utility	5
Grading	5
Backfilling	5
Operating Environment	5
Section 4 Maintenance	6
Section 5 Troubleshooting Guide	7
Section 6 Replacement Parts	8
ABH-96	8-10
Section 7 Reference	11
Bolt Torque	11
Checking Bolt Torque	11
Torque Specifications Coarse Thread	11
Torque Specifications Fine Thread & Head Markings	12
Section 8 Warranty	13
Notes	14

To Our Customers

We at Hardee by EVH Manufacturing Company thank you for buying your new Heavy-Duty Scraper Blade.

We have tried hard to build a heavy-duty scraper blade to do the work you have in mind. Many hours of engineering, field-testing and improvement have gone into the design and fabrication of your heavy-duty scraper blade. We will strive to continue this quality of manufacturing in the future, always keeping the customer's needs clearly in mind.

The best performance of your heavy-duty scraper blade will depend on you. Proper maintenance, hookup, adjustments and operation are essential for it to give you long and dependable service. However, as with any type of equipment, your heavy-duty scraper blade is designed to perform specific functions.

In this manual, you will find instructions on heavy-duty scraper blade features, maintenance and operation. If customer service or repair parts are required, contact your local Hardee dealer. Please specify model and serial number when ordering parts.

Owner's Responsibility

The manufacturer has no control over the ultimate use of the heavy-duty scraper blade and therefore assumes no responsibility or liability for damage or injury resulting from the use of this equipment.

The upkeep of the heavy-duty scraper blade is the responsibility of the user. This upkeep includes all shielding, guards, and safety decals (OSHA Regulation 1928.57). You can obtain replacement parts from any authorized Hardee dealer.

Read this Operator's Manual before using the heavy-duty scraper blade. Failure to do so could result in injury to the operator or to others. Remember that most accidents occur due to neglect or carelessness. The operator is responsible for inspecting and making repairs as may be necessary. Cleaning after each use and storage under a shelter will extend the life of the heavy-duty scraper blade.

Purpose of This Manual

This manual provides information on safety, operation, adjustments, troubleshooting and maintenance of your new heavy-duty scraper blade. Please read and follow all the recommendations to help ensure that you get

many years of service from your new Hardee heavy-duty scraper blade.

If you need additional copies of this manual, please contact your local Hardee dealer or download a copy from our website at www.hardeebyevh.com.

Safety-Alert Symbol



This symbol is the safety alert symbol. It appears throughout this manual to call your attention to instructions involving your personal safety and the safety of others. Failure to follow these instructions can result in injury or death.

Signal Words

Safety signal words are words that call attention to the safety sign and designate a degree or level of hazard seriousness. The signal words used throughout this manual are DANGER, WARNING and CAUTION. Please read and follow all safety messages that have these signal words shown for your protection.



DANGER

Indicates an imminently hazardous situation which, if not avoided, will result in death or serious injury.



WARNING

Indicates a potentially hazardous situation which, if not avoided, could result in death or serious injury.



CAUTION

Indicates a potentially hazardous situation which, if not avoided, may result in minor or moderate injury.

Customer Assistance

The Hardee sales team would like you to be satisfied with your new Heavy-Duty Scraper Blade. If for some reason you have any questions about the information in this manual or have a problem with your heavy-duty scraper blade, please discuss the problem or question with the management of your local dealership. If further assistance is required, please contact:

Hardee By EVH Manufacturing Company, LLC
Sales Department
4895 Red Bluff Road, Loris, SC 29569
843-756-2555

Safety Information

General Safety Rules

This section of your manual will address the safe operation of your new heavy-duty scraper blade. We at Hardee strive to produce equipment that is both a quality product and safe to operate. Please take the time to read, understand and follow the safety rules listed below and throughout this manual.

Your safety also depends on you becoming familiar with the basic operation of your new heavy-duty scraper blade. You can find complete instructions for this heavy-duty scraper blade in the Operation Instruction section of this manual. We believe that using your heavy-duty scraper blade safely, in a safe environment will give you great results!

DANGER

This equipment is designed to be used with a Roll Over Protective Structure (ROPS) equipped tractor of not more than 60 HP. The ABH Heavy-Duty Scraper Blade is designed to grade or move loose, granular material. No other use is intended.

There are obvious and hidden potential hazards in operating Heavy-Duty Rear Blades, as in all power-driven equipment. REMEMBER! This machine is often operated in rough terrain conditions that include gullies, holes, slopes, hidden obstructions and the like. Serious injury or even death may occur unless care is taken to assure the safety of the operator and bystanders in the area.

Included here is a list of safety messages which should be followed. Observing these messages and using common sense learned from experience will go far toward eliminating the hazards of operating this and other such machinery.

DANGER

Read this manual and the manual for the tractor carefully to acquaint yourself with both machines before operating. REMEMBER! Power-driven equipment should be operated only by those trained and familiar with the operation and instructed to do so. Working with unfamiliar equipment or in unfamiliar conditions can lead to accidents.

WARNING

Do not modify or alter this machine or any of its components or any equipment function without consulting Hardee By EVH Mfg. Customer Service.

WARNING

Failure to keep the tractor level may result in loss of traction, tipping, rollover, property damage, personal injury or death.

WARNING

The operator and all support personnel should wear hard hats, safety glasses, and safety shoes for personnel protection.

WARNING

Before leaving the tractor seat, always engage the tractor brake and/or set the tractors transmission in parking gear. Set the Blade on the ground or securely block up. Stop engine and remove key.

DANGER

Falling while mounting or dismounting a moving tractor can cause crushing injury or death.

WARNING

Operate tractor controls from the seat only. Inadvertent dropping or movement of components may cause serious injury or death.









DANGER

Never allow children to play or ride on tractor or equipment. Children may also distract the operator and cause an accident due to inattention.

DANGER

On rear blades that will fall down if not supported, always set on a hard flat surface, with stand installed properly to prevent falling and possible crushing and or back injury from heavy lifting.

SAFETY DECALS

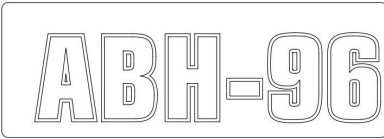
		
11636-ITEM 1 (1)	11636-ITEM 2 (1)	11636-ITEM 3 (3)
		
11636-ITEM 4 (2)	11636-ITEM 5 (2)	11636-ITEM 6 (1)
		WWW.HARDEEBYEVH.COM
11032-ITEM 7 (2)	11131-ITEM 8 (1)	11850-ITEM 9 (1)
		
11610-ITEM 10 (1)		
ITEM	PART NUMBER / (QTY)	DESCRIPTION
1	11636-ITEM 1 (1)	WARNING DECAL
2	11636-ITEM 2 (1)	WARNING DECAL
3	11636-ITEM 3 (3)	WARNING DECAL
4	11636-ITEM 4 (2)	WARNING DECAL
5	11636-ITEM 5 (2)	DANGER DECAL
6	11636-ITEM 6 (1)	WARNING DECAL
7	11032-ITEM 7 (2)	Small Hardee Decal
8	11131-ITEM 8 (1)	Large Hardee Decal
9	11850-ITEM 9 (1)	Web Site Decal
10	11610-ITEM 10 (1)	ABH-96 I.D. DECAL (LARGE)
	11636 (1)	Safety Decal Sheet

Safety Information

Safety Decals Locations

Your Hardee heavy-duty scraper blade ships with all safety decals in place. They are located in areas on the scraper that are potentially hazardous. Please locate, read and follow the information you find on these decals.

By law, you must replace any safety decals that are damaged or missing. You can order replacement decals from any local Hardee dealer. Just ask for part number 11636.

To apply the replacement decals:

- Clean the surface to place the new decal.
- Peel the decal away from the paper backing.
- Press firmly onto the clean surface.
- Squeeze out any air pockets using a straight edge.

DECAL CHART

Note: Part Number 11636 can not be ordered as individual items.

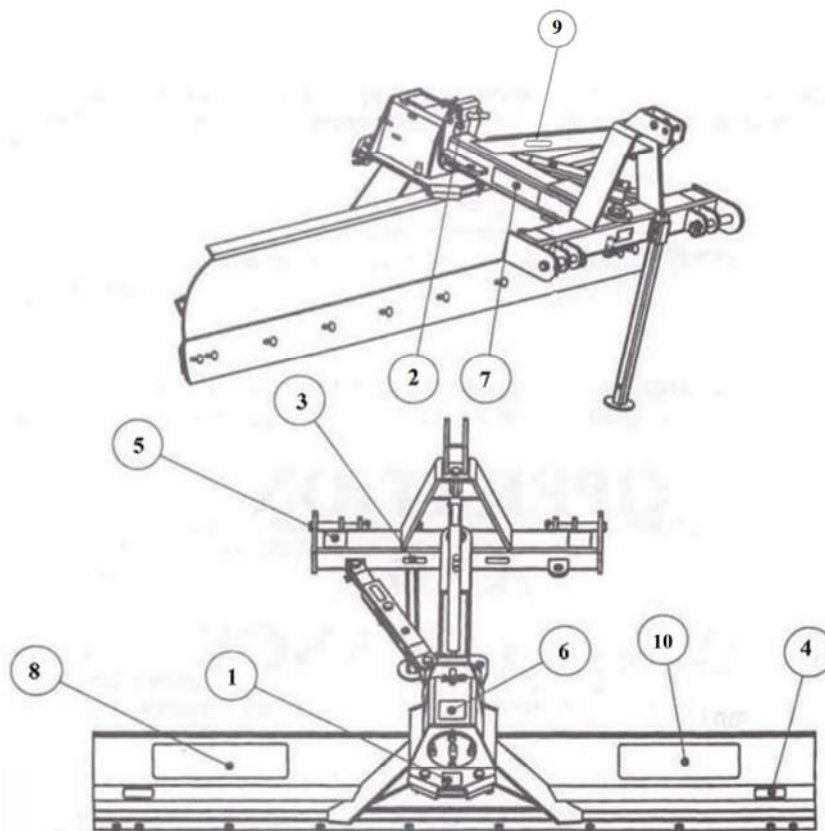

Operation Instruction

Operation Instructions

During Operation

Your ABH Heavy-Duty Scraper Blade should now be assembled and inspected for any evidence of defective or damaged parts before use. Any evidence of damage should be reported to your dealer immediately. All joints requiring grease should be inspected and greased if necessary.

A variety of Blade Positions are possible with mechanical Adjust Links.

CENTER FRAME - SWING:

A 6 position mechanical adjusting link will swing the center frame a maximum of 30 degrees right or left.

REAR BLADE - PIVOT:

An 18 position mechanical adjusting plate will pivot the rear blade a maximum of 60 degrees right or left from perpendicular to the center frame.



WARNING

Always check to see that the castle nut is secured to the pivot bolt before rotating the rear blade. If the castle nut is missing, the rear blade can fall off while pivoting causing serious injury.

REAR BLADE - TILT:

A 5 position mechanical adjusting plate will tilt the rear blade a maximum of 30 degrees to either side of horizontal.

UTILITY:

To clean close to a fence or barn, offset the center frame to the right or left to extend the blade beyond the tractor tire. Be careful not to hang the blade tip as this could result in damage to the blade or center frame. For smoothing out loose soil a fine finish can be obtained by pushing the soil with the back of the rear blade.

GRADING:

Set the rear blade pivot to the desired angle, lower the blade to the ground and then set the depth of cut using the tractor's draft or lift controls.

BACKFILLING:

The rear blade can be manually rotated 180 degrees for backfilling operations. This position requires a careful setting of the top link allowing a blade angle, which does not tend to bury itself, but move more across the top of the ground. Backfilling is a very critical operation because the blade tends to dig into the ground. The backfilling operation should be performed with the center frame straight behind the tractor with the blade set in the center position (perpendicular to the center frame). The work should be kept in the center of the blade. Avoid concentrated loads on the end of the blade. Do not ram into a load at any time as this multiplies the forces several times normal and could result in damage to your blade. Perform all backfilling operations at slow speeds to prevent damage if the blade hits an object. Moving snow with the blade in the backfill position is a very delicate operation and should be performed with care. It is very easy to hit hidden objects when moving the light snow. It is also very easy to operate the blade at too high a speed, resulting in damage.

Operating Environment

Application Do's and Don'ts

There are obvious and hidden potential hazards in operating this equipment. **REMEMBER!** This equipment is often operated in rough terrain conditions that include gullies, holes, slopes and hidden obstructions. Serious injury or even death may occur unless care is taken to assure the safety of the operator and bystanders in the area.

MAINTENANCE

- The ABH series are rugged, heavy-duty Blades that will perform satisfactorily with the following preventive maintenance.
- Lubricate the Rear Blade Pivot Pin and the Rear Blade Tilt Pin after every 10 hours of operation.
- Replace excessively worn Grader Blade when Ditching. A badly worn cutting edge increases the strain on the Blade and the tractor.
- The ABH Scraper Blade should be kept rust free, and with a good coat of paint.

TROUBLESHOOTING

PROBLEM	POSSIBLE CAUSE	REMEDY
Shearing M/B Carrier Pivot Pin Bolt	Lack of lubrication. Bolt not tightened properly.	Lubricate Pivot Pin. Tighten Bolt to proper torque
Bent Rear Blade	Small curve is normal from weld pull. Hitting hidden objects/	Can be removed but will not affect operation. Know soil conditions, keep speed to a minimum.
Blade will not penetrate Soil	Cutting edge dull. Blade set to straight. Soil too hard.	Replace Cutting Edge. Increase Top Link length. Use scarifiers to loosen soil.
A-Frame bent	Hitting hidden objects in the Backfill position.	Use slow speed when in unknown soil conditions.
Rear Blade digging in too much	Blade pitch excessive. Soft ground.	Adjust Top Link. Install Skid Shoes.
Unable to hold level ground	Tractor and Blade following contour. Tractor Draft Control lifting Blade.	Adjust Tractor Draft Control. Set Tractor Draft Control.

SECTION 6 - REPLACEMENT PARTS

ABH-96 Rear Blade Complete

DWG. NO.	40034		REV.	G
REV	CHANGE	BY	DATE	ECN
G	Weldment updated (Complete machine created in Creo 2.0)	T.B.B.	8/25/15	1626

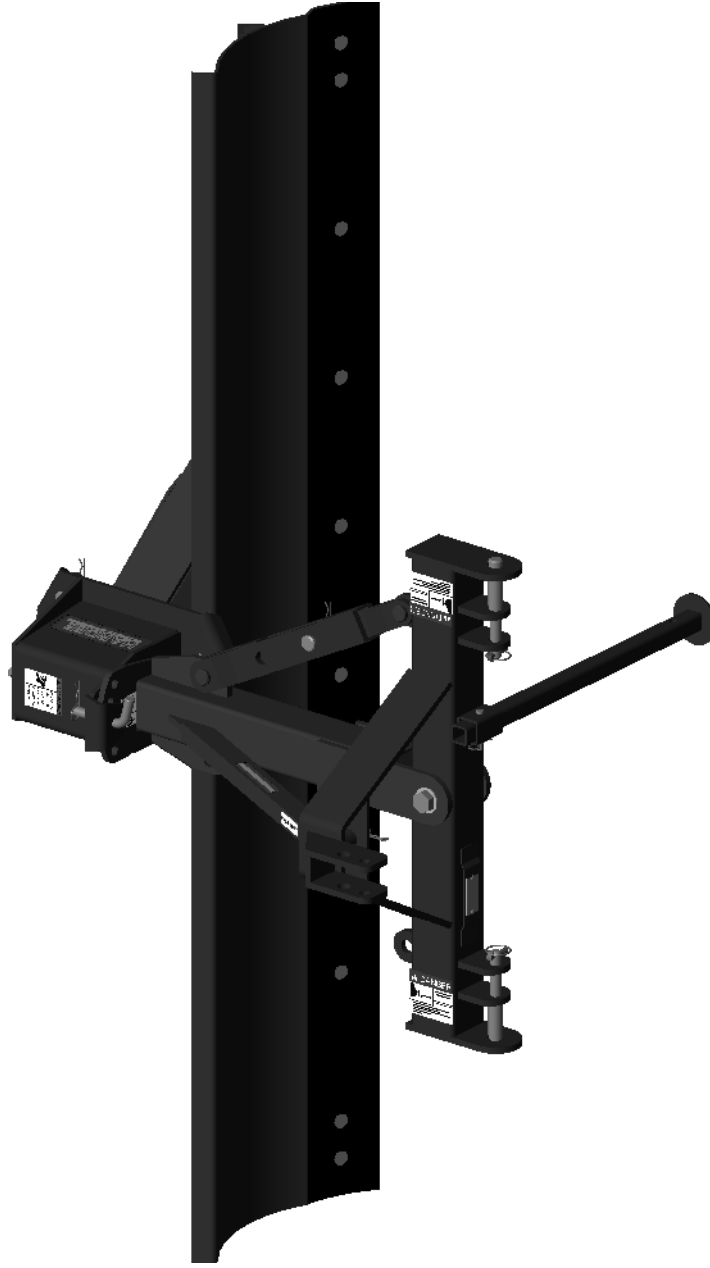

Item	Part Number	Qty.	Description
1	10072	4	Hex Bolt 1/2 x 1 1/2 gr.5 plated
2	10136	1	Hex Bolt 1 x 6 1/2 gr.5 plated
3	10166	10	Lock Nut 5/8"-11 plated
4	10171	1	Lock Nut 1" plated
5	10184	4	Lockwasher 1/2 plated
6	10207	4	Flatwasher, 1" plated
7	10252	1	Cotter Pin 3/16" X 2" Plated
8	10262	10	Plow Bolt 5/8 x 1 1/2 Gr.5 Plated
9	10335	1	Hardee Red Paint - (Not Shown)
10	10339	2	Pop Rivet
11	10346	2	3 pt. Snap Pin (Lynch Pin)
12	10390	1	Clip Pin (1/8 x 2)
13	10391	7	Clip Pin (Hairpin) 3/16 X 3-1/4"
14	10393	1	Universal Clip Pin
15	10434	1	96 Cutting Edge
16	10445	1	3/4 Dia. Bent Hitch Pin
17	10446	5	Clevis Pin (1 X 2 5/8)
18	10447	1	Clevis Pin (1 X 5)
19	10464	2	Category I and II Hitch Pin
20	11032	2	Small Hardee Logo Decal
21	11131	1	Large Hardee Logo Decal
22	11413	1	Castle Nut (1) Gr.5 Plated Fine Thread
23	11610	1	ABH-96 I.D. DECAL (LARGE)
24	11636	1	Safety Decal Sheet
25	11636-1	1	WARNING DECAL (KIT 15845)
26	11636-2	1	WARNING DECAL (KIT 15845)
27	11636-3	3	WARNING DECAL (KIT 15845)
28	11636-4	2	WARNING DECAL (KIT 15845)
29	11636-5	2	DANGER DECAL (KIT 15845)
30	11636-6	1	WARNING DECAL (KIT 15845)
31	11727	1	Serial Number Plate
32	11850	1	Web Site Decal
33	40035	1	Rear Blade Front Frame Weldment
34	40036	1	Rear Blade Center Frame Weldment
35	40037	1	Rear Blade Carriage Housing Weldment
36	40039	1	Rear Blade Inner Stabilizer Weldment
37	40040	1	Rear Blade Outer Stabilizer Weldment
38	40058	1	Outer Pivot Cap
39	40087	1	ABH96 Rear Blade Weldment
40	40227	1	Pivot Bolt Weldment
41	40308	1	ABH Stand Weldment

MODELED BY	JIM CREEL	N/A
DRAWN BY	T.B.B.	8/25/15
MATERIAL	R.M.N.	
	N/A	
DESCRIPTION		
ABH-96 Rear Scraper		
DO NOT SCALE	A	DWG. NO.
		40034
HARDEE BY		
EVH MFG. CO.		
LORIS S.C.		
SHEET 1 of 3		

All Dimensions in Inches Unless Otherwise Specified

Dimensions in [] are in Millimeters

Tolerance Unless Otherwise Specified

Fractional Dimensions ± 1/16" Angular Dimensions ± 1°

Decimal Dim. to Limits Shown All Holes to be +0 -1/32"

SECTION 6 - REPLACEMENT PARTS

DWG. NO.	40034			REV.	G		
REV	CHANGE	BY	DATE	ECN			
G	Weldment updated (Complete machine created in Creo 2.0)	T.B.B.	8/25/15	1626			

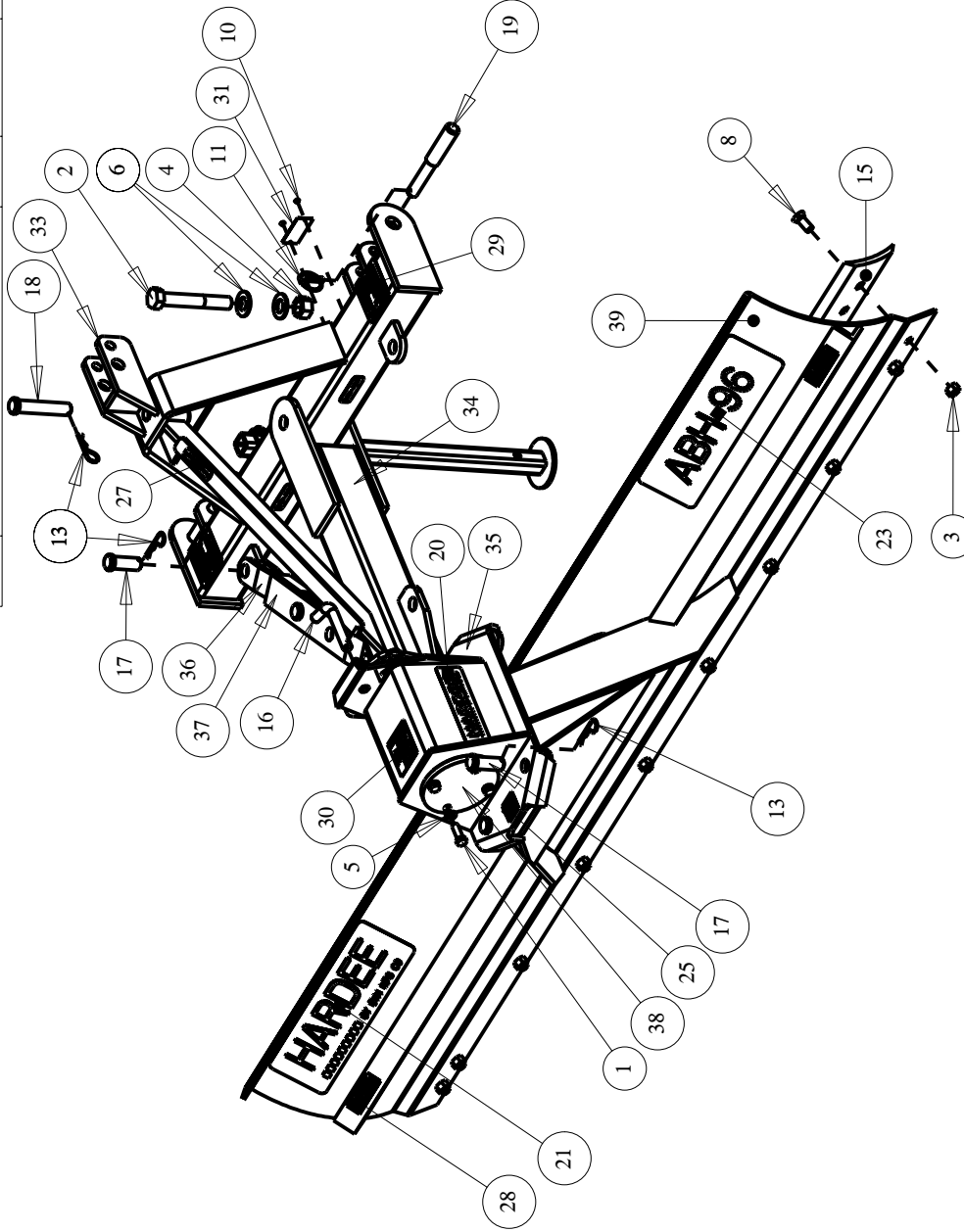

Item	Part Number	Qty.	Description
1	10072	4	Hex Bolt 1/2 x 1 1/2 gr.5 plated
2	10136	1	Hex Bolt 1 x 6 1/2 gr.5 plated
3	10166	10	Lock Nut 5/8"-11 plated
4	10171	1	Lock Nut 1" plated
5	10184	4	Lockwasher 1/2 plated
6	10207	4	Flatwasher, 1" plated
7	10252	1	Cotter Pin 3/16" X 2" Plated
8	10262	10	Plow Bolt 5/8 x 1 1/2 Gr.5 Plated
9	10335	1	Hardee Red Paint - (Not Shown)
10	10339	2	Pop Rivet
11	10346	2	3 pt. Snap Pin (Lynch Pin)
12	10390	1	Clip Pin (1/8 x 2)
13	10391	7	Clip Pin (Hairpin) 3/16 X 3-1/4"
14	10393	1	Universal Clip Pin
15	10434	1	96 Cutting Edge
16	10445	1	3/4 Dia. Bent Hitch Pin
17	10446	5	Clevis Pin (1 X 2 5/8)
18	10447	1	Clevis Pin (1 X 5)
19	10464	2	Category I and II Hitch Pin
20	11032	2	Small Hardee Logo Decal
21	11131	1	Large Hardee Logo Decal
22	11413	1	Castle Nut (1) Gr.5 Plated Fine Thread
23	11610	1	ABH-96 I.D. DECAL (LARGE)
24	11636	1	Safety Decal Sheet
25	11636-1	1	WARNING DECAL (KIT 15845)
26	11636-2	1	WARNING DECAL (KIT 15845)
27	11636-3	3	WARNING DECAL (KIT 15845)
28	11636-4	2	WARNING DECAL (KIT 15845)
29	11636-5	2	DANGER DECAL (KIT 15845)
30	11636-6	1	WARNING DECAL (KIT 15845)
31	11727	1	Serial Number Plate
32	11850	1	Web Site Decal
33	40035	1	Rear Blade Front Frame Weldment
34	40036	1	Rear Blade Center Frame Weldment
35	40037	1	Rear Blade Carriage Housing Weldment
36	40039	1	Rear Blade Inner Stabilizer Weldment
37	40040	1	Rear Blade Outer Stabilizer Weldment
38	40058	1	Outer Pivot Cap
39	40087	1	ABH96 Rear Blade Weldment
40	40227	1	Pivot Bolt Weldment
41	40308	1	ABH Stand Weldment

MODELED BY	JIM CREEL	N/A	R.M.N.	SHEET 2 of 3
DRAWN BY	T.B.B.	8/25/15		
MATERIAL	N/A			DESCRIPTION
Manufactured By: EVH Mfg. Co., LLC				ABH-96 Rear Scraper
DO NOT SCALE	A	DWG. NO.	40034	

All Dimensions in Inches Unless Otherwise Specified
 Dimensions in [] are in Millimeters
 Tolerance Unless Otherwise Specified
 Fractional Dimensions ± 1/16"
 Angular Dimensions ± 1°
 Decimal Dim. to Limits Shown
 All Holes to be +0 -1/32"

HARDEE BY	
EVH MFG. CO.	
LORIS S.C.	

SECTION 6 - REPLACEMENT PARTS

DWG. NO.	40034			REV.	G		
REV	CHANGE	BY	DATE	ECN			
G	Weldment updated (Complete machine created in Creo 2.0)	T.B.B.	8/25/15	1626			

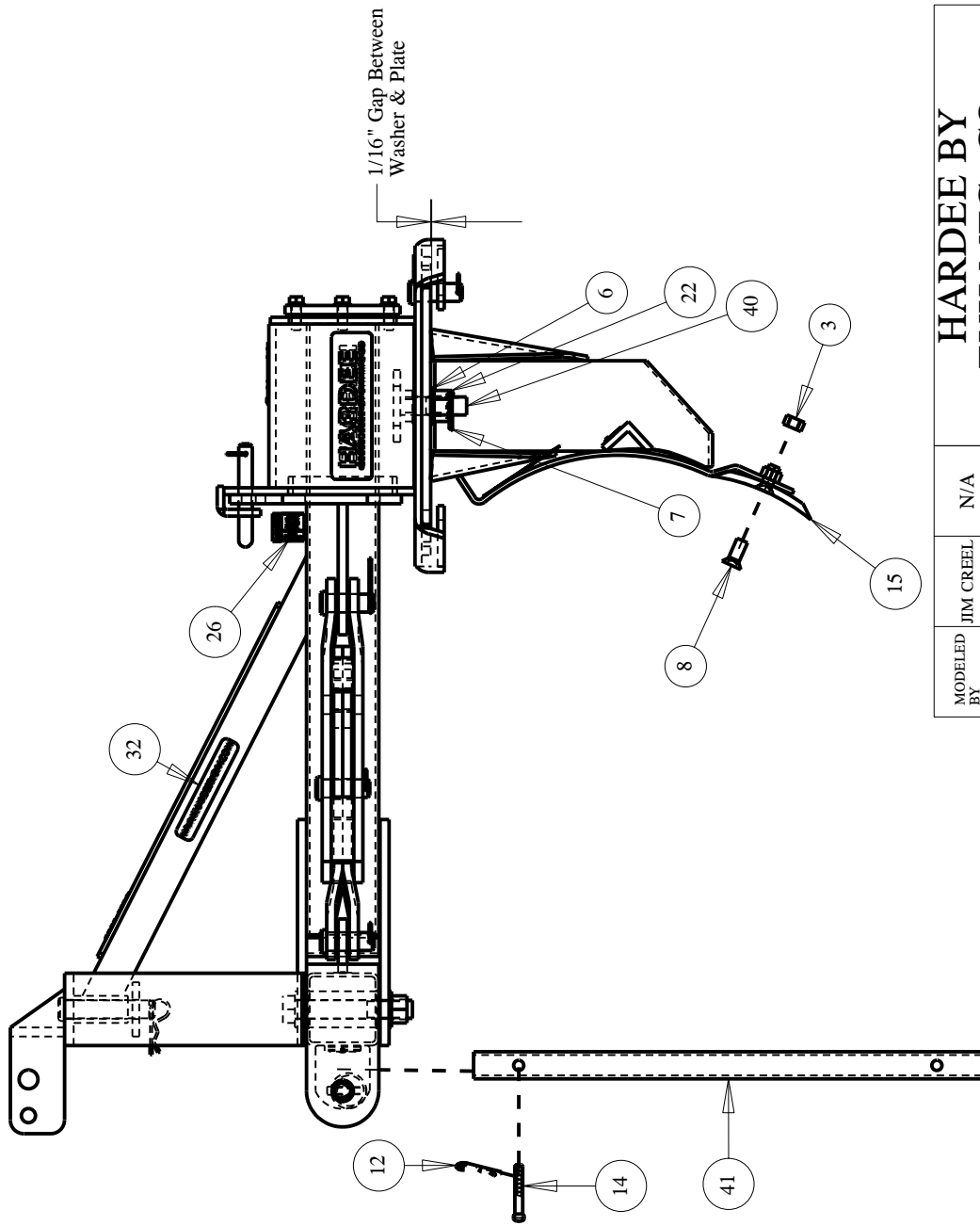

Item	Part Number	Qty.	Description
1	10072	4	Hex Bolt 1/2 x 1 1/2 gr.5 plated
2	10136	1	Hex Bolt 1 x 6 1/2 gr.5 plated
3	10166	10	Lock Nut 5/8"-11 plated
4	10171	1	Lock Nut 1" plated
5	10184	4	Lockwasher 1/2 plated
6	10207	4	Flatwasher, 1" plated
7	10252	1	Cotter Pin 3/16" X 2" Plated
8	10262	10	Plow Bolt 5/8 x 1 1/2 Gr.5 Plated
9	10335	1	Hardee Red Paint - (Not Shown)
10	10339	2	Pop Rivet
11	10346	2	3 pt. Snap Pin (Lynch Pin)
12	10390	1	Clip Pin (1/8 x 2)
13	10391	7	Clip Pin (Hairpin) 3/16 X 3-1/4"
14	10393	1	Universal Clip Pin
15	10434	1	96 Cutting Edge
16	10445	1	3/4 Dia. Bent Hitch Pin
17	10446	5	Clevis Pin (1 X 2 5/8)
18	10447	1	Clevis Pin (1 X 5)
19	10464	2	Category I and II Hitch Pin
20	11032	2	Small Hardee Logo Decal
21	11131	1	Large Hardee Logo Decal
22	11413	1	Castle Nut (1) Gr.5 Plated Fine Thread
23	11610	1	ABH-96 I.D. DECAL (LARGE)
24	11636	1	Safety Decal Sheet
25	11636-1	1	WARNING DECAL (KIT 15845)
26	11636-2	1	WARNING DECAL (KIT 15845)
27	11636-3	3	WARNING DECAL (KIT 15845)
28	11636-4	2	WARNING DECAL (KIT 15845)
29	11636-5	2	DANGER DECAL (KIT 15845)
30	11636-6	1	WARNING DECAL (KIT 15845)
31	11727	1	Serial Number Plate
32	11850	1	Web Site Decal
33	40035	1	Rear Blade Front Frame Weldment
34	40036	1	Rear Blade Center Frame Weldment
35	40037	1	Rear Blade Carriage Housing Weldment
36	40039	1	Rear Blade Inner Stabilizer Weldment
37	40040	1	Rear Blade Outer Stabilizer Weldment
38	40058	1	Outer Pivot Cap
39	40087	1	ABH96 Rear Blade Weldment
40	40227	1	Pivot Bolt Weldment
41	40308	1	ABH Stand Weldment

All Dimensions in Inches Unless Otherwise Specified
Dimensions in [] are in Millimeters

Tolerance Unless Otherwise Specified

Fractional Dimensions ± 1/16"
Angular Dimensions ± 1°
Decimal Dim. to Limits Shown
All Holes to be +0 -1/32"

**HARDEE BY
EVH MFG. CO.**
LORIS S.C.

MODELED BY: JIM CREEL
DRAWN BY: T.B.B.
MATERIAL: N/A
R.M.N.: N/A

DESCRIPTION: ABH-96 Rear Scraper
SHEET 3 of 3
DO NOT SCALE: A
DWG. NO.: 40034

Manufactured By:
EVH Mfg. Co., LLC

Bolt Torque

Checking Bolt Torque

The tables shown below give correct torque values for various bolts and capscrews. Tighten all bolts to the torque specified in the chart unless otherwise noted. Check tightness of bolts periodically, using bolt torque chart as a guide. Replace hardware with the same strength bolt. Torque figures indicated are valid for non-greased or non-oiled threads and heads unless otherwise specified. Therefore, do not grease or oil bolts or cap screws unless otherwise specified in this manual. When using locking elements, increase torque values by 5%.

NOTE: Bolt Torques shown are maximum allowable values for ultimate safe working strength or external load-carrying capacity. The bolt torque are not applicable in cases where bolts are used as a pin-like device, holding together two or more movable objects and keeping them from spreading apart. – “Clamping Torque” Being dependent upon the application of the bolt. -

*Torque value for bolts and cap screws are identified by their head markings.
See Page 21.*

Torque Specifications for Coarse Threads

Diameter “A”	Bolt Torque		Coarse Thread			
	SAE-2		SAE-5		SAE-8	
	LB-FT	N.m	LB-FT	N.m	LB-FT	N.m
1/4" - 20	6	8	9	12	12	17
5/16" - 18	10	13	19	25	27	36
3/8" - 16	20	27	33	45	45	63
7/16" - 14	30	41	53	72	75	100
1/2" - 13	45	61	80	110	115	155
9/16" - 12	70	95	115	155	165	220
5/8" - 11	95	128	160	215	220	305
3/4" - 10	165	225	290	390	400	540
7/8" - 9	170	230	420	570	650	880
1" - 8	225	345	630	850	970	1320
1 1/8" - 7	354	478	794	1072	1287	1737
1 1/4" - 7	500	675	1120	1512	1875	2531
1 3/8" - 6	655	884	1470	1985	2382	3216
1 1/2" - 6	870	1175	1950	2632	3161	4267

See page 21 for Torque Specifications for Fine Threads and Head Markings

Torque Specifications for Fine Threads

Diameter "A"	Bolt Torque					
	SAE-2		SAE-5		SAE-8	
	LB-FT	N.m	LB-FT	N.m	LB-FT	N.m
1/4" - 28	6	8	10	14	14	19
5/16" - 24	12	16	19	26	27	36
3/8" - 24	22	31	35	47	49	66
7/16" - 20	36	49	55	74	78	105
1/2" - 20	55	74	85	115	120	162
9/16" - 18	80	108	122	165	172	232
5/8" - 18	110	148	170	230	240	324
3/4" - 16	200	270	297	400	420	567
7/8" - 14	180	243	474	640	668	402
1" - 12	274	370	705	952	995	1343
1" - 14	280	378	721	973	1019	1376
1 1/8" - 12	397	536	890	1201	1444	1950
1 1/4" - 12	553	747	1241	1675	2012	2716
1 3/8" - 12	746	1007	1672	2257	2712	3661
1 1/2" - 12	979	1322	2194	2962	3557	4802

Head Markings

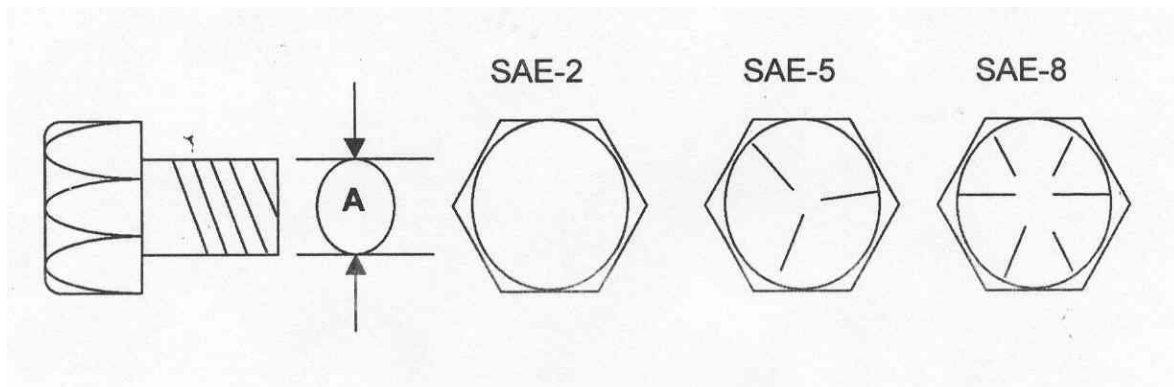

Hardee by EVH Manufacturing Co., LLC Limited Warranty

Hardee by EVH Manufacturing Co., LLC warrants its **Equipment*** for one year to the **original** non-commercial, non-governmental, or non-municipal purchaser. For the **original** commercial, industrial, or municipal purchaser, the goods are warranted for 90 days to be free from defects in material or workmanship.

Special OMNI Gearbox Warranty:

OMNI Gearboxes are warranted for a total of:

3 years to the original non-commercial user

1 year to the original commercial user

This limited warranty does not apply to any part of the goods which have been subjected to improper or abnormal use, negligence, alteration, modification, accident, or damage due to lack of maintenance, wrong oil or lubricants, or which has served its normal life.

The Warranty Card **must** be filled out and returned within **30 days** of purchase. **No** warranty will be allowed without a properly completed and returned warranty card.

“Our obligation under this warranty shall be limited to repair or replacement of any part or parts of this implement, which in our judgement, shows evidence of such defect, and provided further, that said parts shall be removed and returned by the owner at the owner’s expense to Hardee by EVH Manufacturing Co., LLC, Loris, SC, through an authorized dealer, transportation prepaid, free and clear of liens or encumbrances.”

This warranty shall not include normal wear items.

Changes or alterations to the implement made without the **written** authorization of the manufacturer will render this warranty void.

This warranty does not obligate this company to bear any labor costs in replacement of defective parts.

Hardee by EVH Manufacturing Co., LLC reserves the right to make changes or improvements in its equipment at any time, with the express understanding that such changes or improvements do not impose any obligation of the company to install such changes or improvements on implements previously manufactured.

IMPLIED WARRANTIES: You may have some implied warranties. For example, you may have an implied warranty of merchantability (that the unit is reasonably fit for the general purpose for which it was sold) or an implied warranty of fitness for a particular purpose (that the unit is suitable for your special purposes). Special purposes must be specifically disclosed to Hardee by EVH Manufacturing Co., LLC and not merely to the dealer before your purchase. Hardee by EVH Manufacturing Co., LLC itself must approve, in writing, that the special purpose is warrantable.

These implied warranties do not apply at all if you use your equipment for business or commercial use.

***See separate Hydraulic Mower Limited Warranty for Hydraulics**

NOTES:

NOTES:

NOTES:



EVH MANUFACTURING COMPANY, LLC
4895 RED BLUFF ROAD LORIS, SC 29569
PHONE: 843-756-2555 OR 1-888-990-2555
WWW.HARDEEBYEVH.COM EVHMFG@HARDEEBYEVH.COM