

ITEM NO.	PART NUMBER	QTY REQD.	NOMENCLATURE OR DESCRIPTION
1	10311	2	1 1/4" NUT FOR BLADE BOLT
2	10312	2	1 1/4" LOCK WASHER FOR BLADE BOLT
3	10313	2	BLADE BOLT
4	10413	2	BLADE
5	20236	1	ROUND BLADE HOLDER WELDMENT

DWG. NO.		REV.	
20304		IR	
REV	CHANGE	BY	DATE
IR	INITIAL RELEASE	T.R.M.	1/19/01
		ECN	----

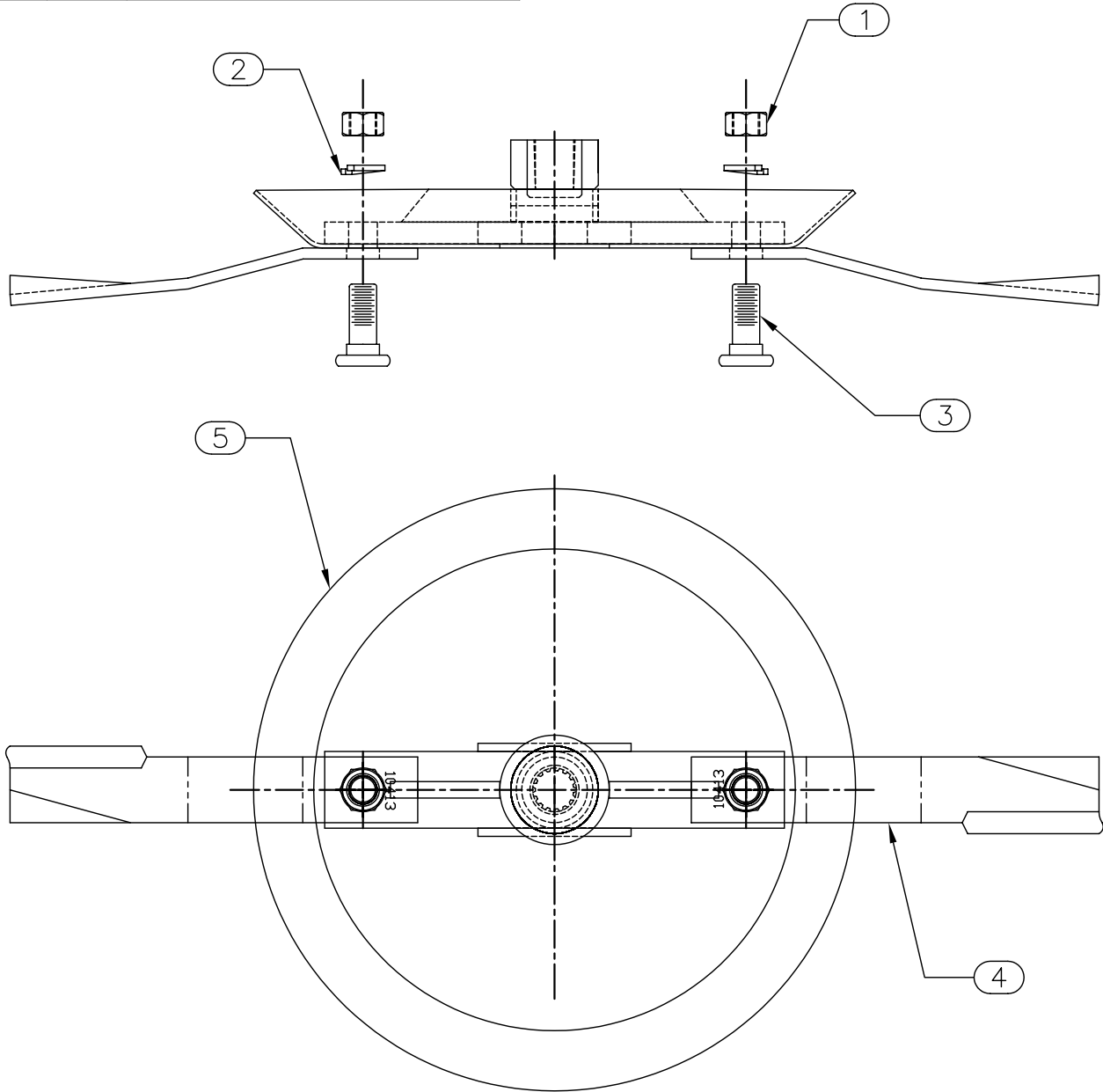

DRAWN BY	T.R.M.	1/19/01	EVH Manufacturing Co. LORIS S.C.	
CHECKED BY				
MATERIAL	R.M.N.		APPLICATION	OLD PART #
MANUFACTURED BY: HARDEE MFG. CO., LLC			1198W	----
			DESCRIPTION BLADE HOLDER WITH BLADES COMPLETE (RIGHT)	
DO NOT SCALE	A	DWG. NO.	20304	
	DWG SIZE			

All Dimensions in Inches Unless Otherwise Specified
Dimensions in [] are in Millimeters

Tolerances Unless Otherwise Specified
Fractional Dimensions $\pm 1/16"$ Angular Dimensions $\pm 1^\circ$
Decimal Dim. to Limits Shown All holes to be $+0$
 $-1/32$

ITEM NO.	PART NUMBER	QTY REQD.	NOMENCLATURE OR DESCRIPTION
1	10311	2	1 1/4" NUT FOR BLADE BOLT
2	10312	2	1 1/4" LOCK WASHER FOR BLADE BOLT
3	10313	2	BLADE BOLT
4	10414	2	REVERSE UPLIFT BLADE
5	20236	1	ROUND BLADE HOLDER WELDMENT

DWG. NO. 20305			REV. IR	
REV	CHANGE	BY	DATE	ECN
IR	INITIAL RELEASE	T.R.M.	1/19/01	----

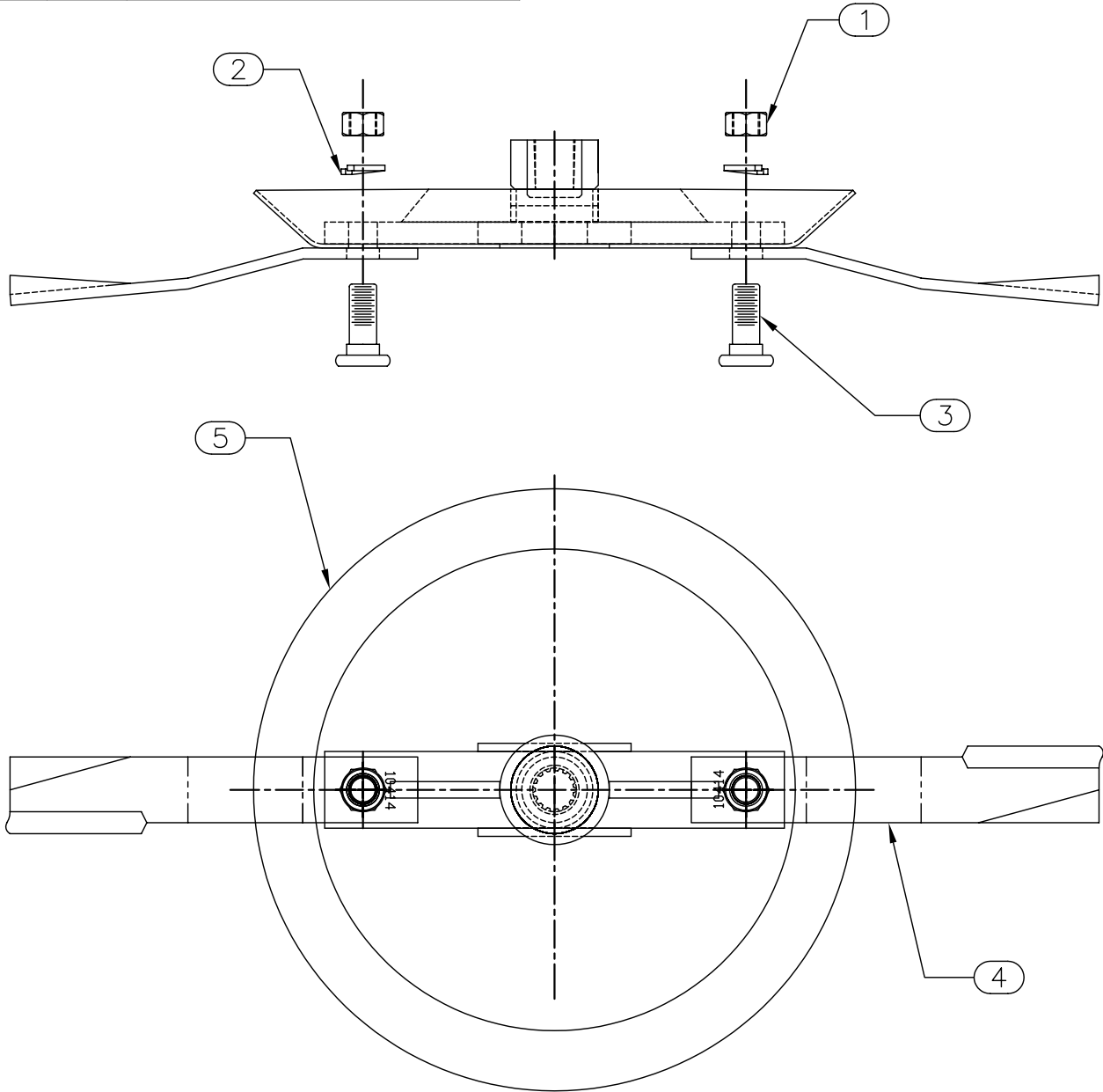

DRAWN BY	T.R.M.	1/19/01	EVH Manufacturing Co. LORIS S.C.	
CHECKED BY				
MATERIAL	R.M.N.		APPLICATION	OLD PART #
MANUFACTURED BY: HARDEE MFG. CO., LLC			1198W	----
			DESCRIPTION BLADE HOLDER WITH BLADES COMPLETE (LEFT)	
DO NOT SCALE	A	DWG. NO.	20305	
	DWG SIZE			

All Dimensions in Inches Unless Otherwise Specified
Dimensions in [] are in Millimeters

Tolerances Unless Otherwise Specified
Fractional Dimensions $\pm 1/16"$ Angular Dimensions $\pm 1^\circ$
Decimal Dim. to Limits Shown All holes to be $+0/-1/32$

10415 Gearbox

(Center Gearbox 1:1 Ratio)

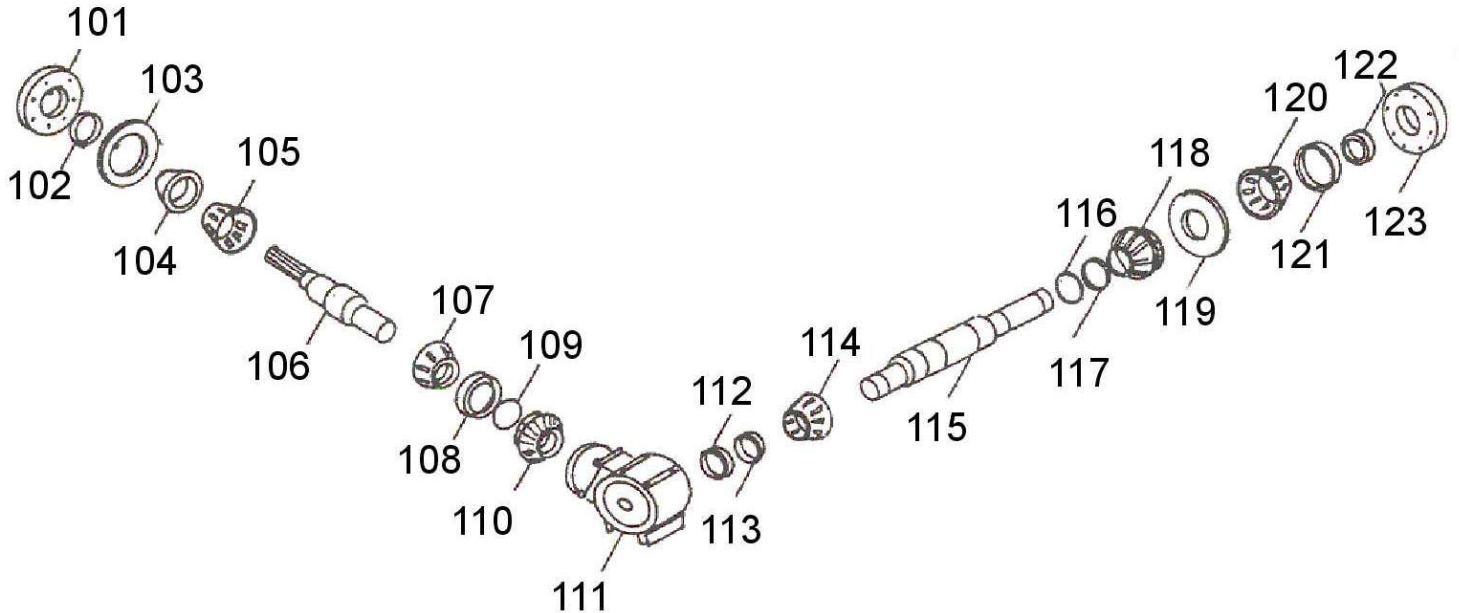

Key #	Part No.	Description	Key #	Part #	Description
101	23013	Input cover plate	114	11241	Bearing
102	10354	Input seal	115	15608	Output shaft
103	10356	Shim	116	10353	Retaining ring
104	11242	Cup	117	15607	Spacer
105	10352	Bearing	118	10684	Output gear
106	15610	Input shaft	119	15732	Shim
107	10352	Bearing		15733	Shim
108	11242	Cup		15734	Shim
109	15593	Spacer	120	11241	Bearing
110	10684	Input gear	121	11240	Cup
111	15770	Gearbox housing	122	15715	Output seal
112	15715	Output seal	123	15768	Side cover plate
113	11240	Cup			

11854 Gearbox

(90H.P. Gearbox 1.93 : 1 Ratio)

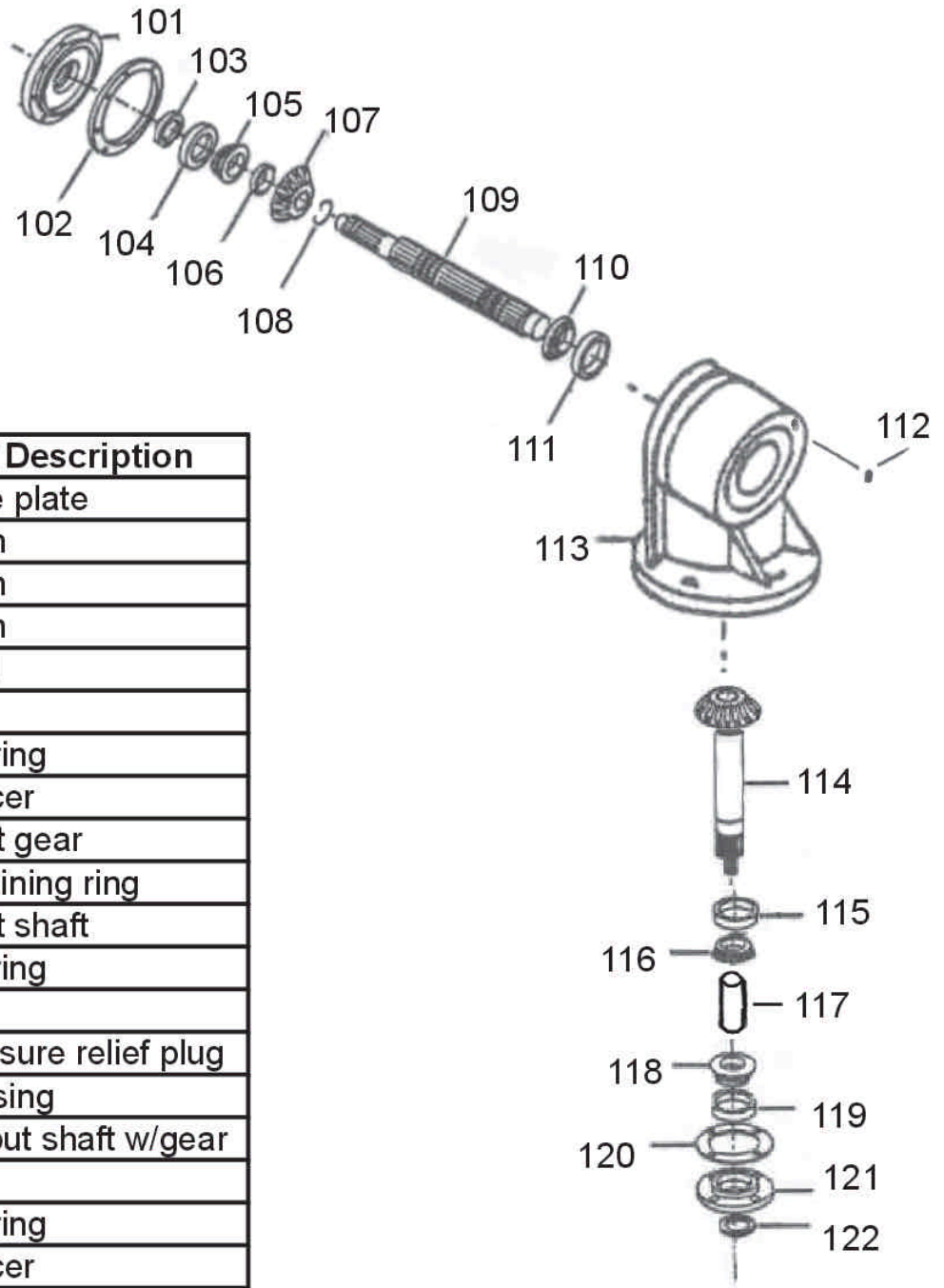

Key #	Part No.	Part Description
101	15768	Face plate
102	15732	Shim
	15733	Shim
	15734	Shim
103	15715	Seal
104	11240	Cup
105	11241	Bearing
106	15606	Spacer
107	15863	Input gear
108	10353	Retaining ring
109	15602	Input shaft
110	11241	Bearing
111	11240	Cup
112	15664	Pressure relief plug
113	11516	Housing
114	15864	Output shaft w/gear
115	11243	Cup
116	10352	Bearing
117	23012	Spacer
118	10352	Bearing
119	11242	Cup
120	15706	Shim
121	15705	Bottom cover
122	10354	Output seal

10422

Outrigger Shaft

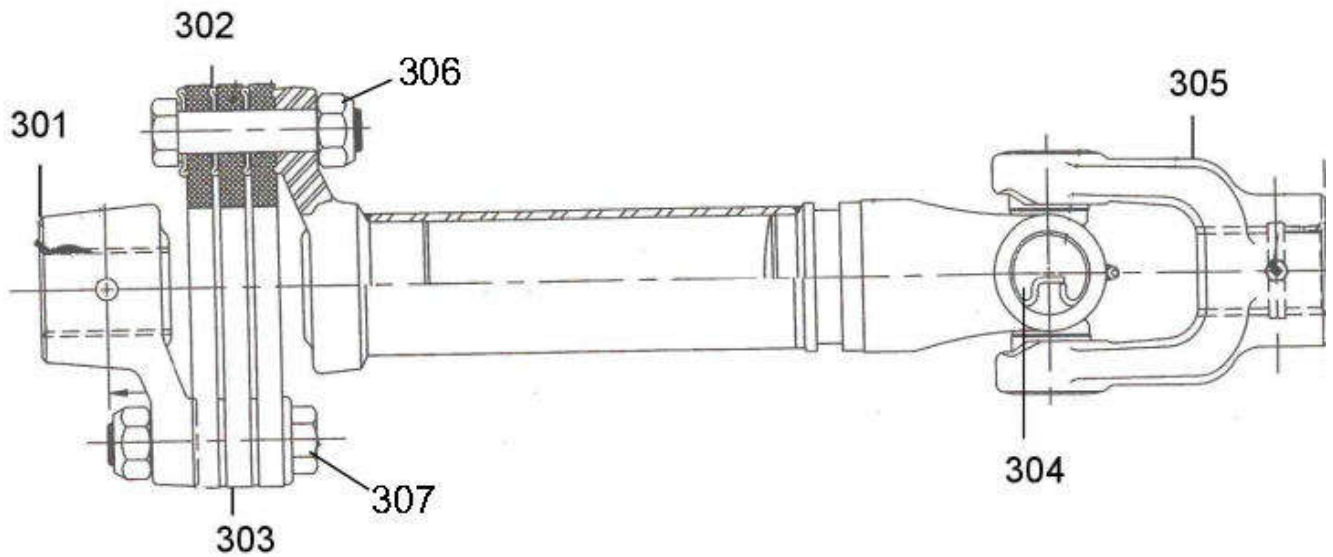

Key#	Part No.	Description
301	11768	6 Spline hub
302	15741	Spacer
303	11769	Rubber disc
304	15538	Cross Kit
305	10702	Yoke, 6 Spline
306	10166	Lock Nut
307	10094	Bolt 5/8 X 3

10619 Driveshaft

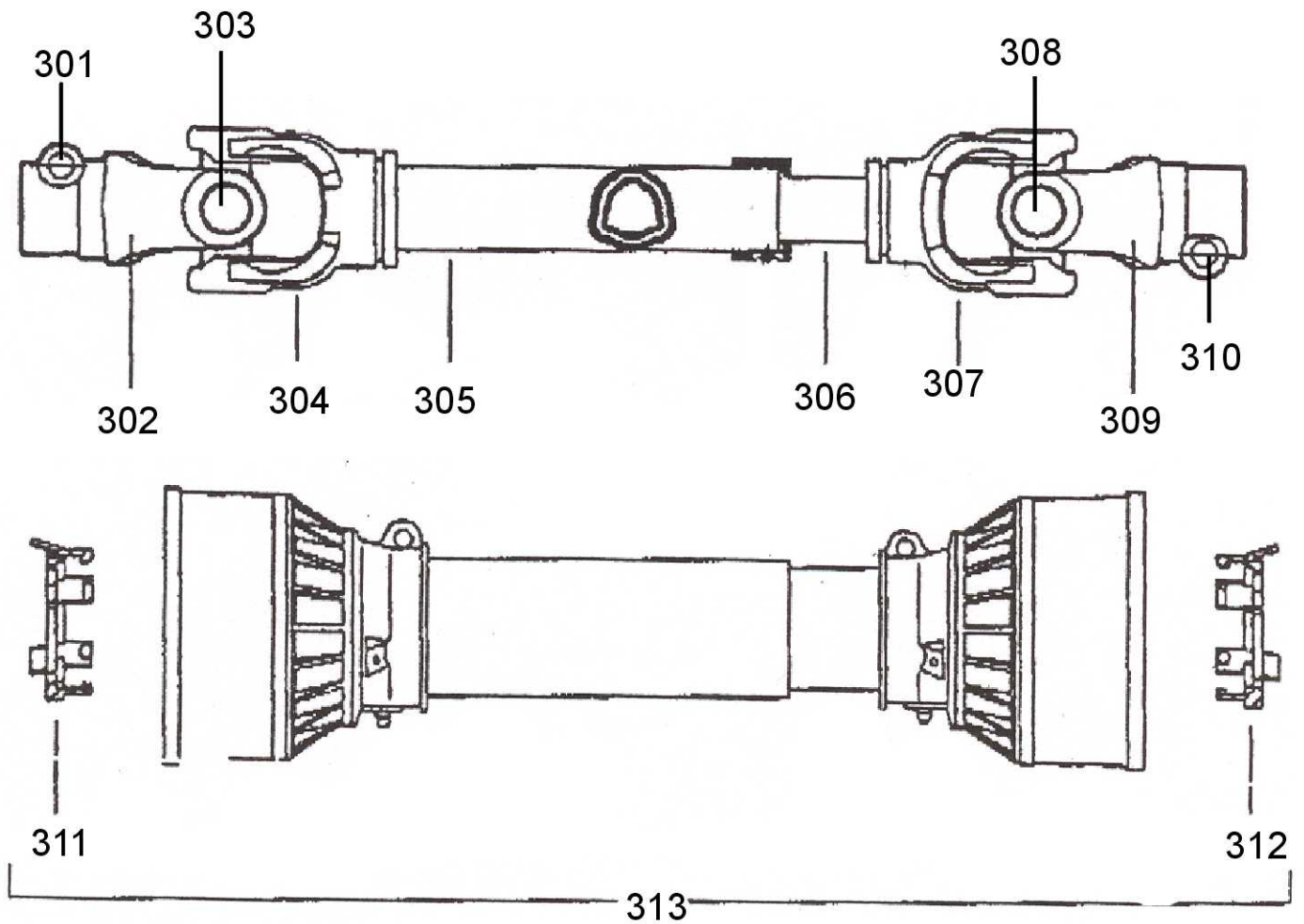

Key #	Part No.	Description	Key #	Part No.	Description
301	15579	Push pin complete	308	15572	Cross kit
302	15571	Yoke, tractor end	309	15571	Yoke, Imp end
303	15572	Cross kit	310	15579	Push pin complete
304	15573	Yoke, large tube	311	15565	Shield bearing
305	15585	Large tube	312	15566	Shield bearing
306	15586	Small tube	313	15812	Shield kit complete
307	15577	Yoke, small tube			

15885 Jackshaft

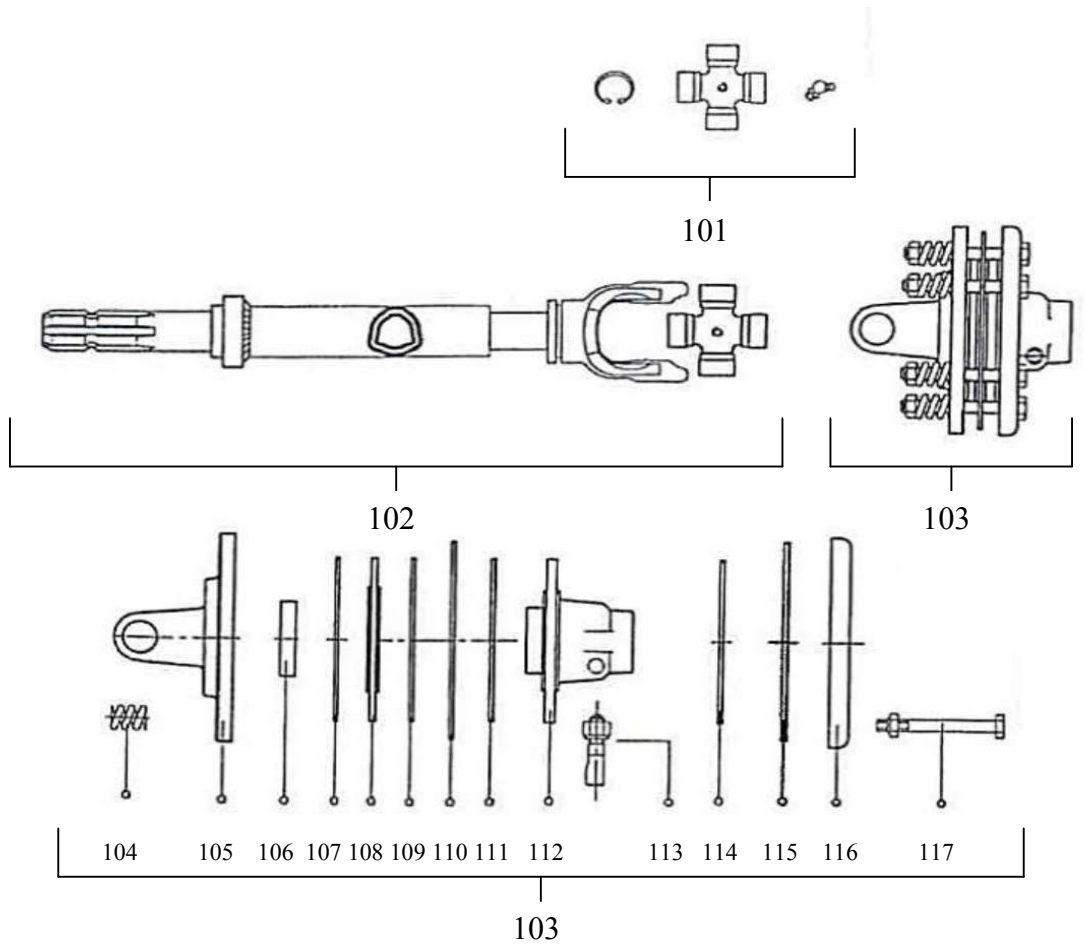

Key #	Part No.	Part Description	Key #	Part No.	Part Description
101	15572	#7 Cross Kit	110	16704	Inner Plate
102	15587	Front Section Shaft	111	11204	Friction Disc
103	15596	Slip Clutch	112	15597	Center Hub For Slip Clutch
104	15561	Spring For Slip Clutch	113	15615	Pin Kit
105	16703	Flanged Yoke	114	11204	Friction Disc
106	15562	Sleeve For Slip Clutch	115	15563	Inner Plate For Slip Clutch
107	11204	Friction Disc	116	15799	Pressure Plate
108	15581	Driving Plate For Slip Clutch	117	15584	Bundle Of 8 Bolts For Slip Clutch
109	11204	Friction Disc			