

ITEM NO.	PART NUMBER	QTY REQD.	NOMENCLATURE OR DESCRIPTION
1	20031	1	ACCESS COVER
2	20035	1	FLOATING LINKAGE WELDMENT
3	20244	2	A-FRAME BRACE
4	20059	1	A-FRAME SUPPORT SPACER
5	20497	1	TAILWHEEL FORK AND ARM ASSEMBLY
6	20491	2	FLAT STRUT
7	10894	2	24" TIE STRAP
8	20298	1	BLADE HOLDER COMPLETE
9	20247	2	BOLT-ON SLIDE
10	20242	2	T/W ADJUSTER PLATES
11	20813	1	FRONT RUBBER BELTING
12	20141	1	FRONT RUBBER SHIELD FLAT
13	20818	1	REAR RUBBER BELTING
14	20819	1	REAR RUBBER SHIELD FLAT
15	10330	1	15" SOLID TIRE AND RIM
16	20195	1	T/W HUB COMPLETE
17	11727	1	SERIAL NUMBER PLATE
18	10339	2	RIVETS FOR SERIAL # PLATE
19	10327	1	90 HP OMNI GEARBOX
20	10475	1	GEAR BOX SHIELD W/ACCESS COVER
21	11566	1	BINACCHI DRIVESHAFT
22	11009	2	MODEL NUMBER DECAL
23	11131	2	EVH LOGO DECAL
24	11001	1	DANGER DECAL
25	11002	2	DANGER KEEP CLEAR DECAL
26	11003	1	CAUTION DECAL
27	11004	1	CAUTION DECAL
28	11005	1	WARNING DECAL
29	11006	1	SAFETY DECAL
30	10307	2	CAT. 1 HITCH PIN
31	10111	4	HEX BOLT (3/4" x 2")
32	10110	2	HEX BOLT (3/4" x 1 1/2")
33	10118	1	HEX BOLT (3/4" x 5 1/2")

DWG. NO.			REV.	
21403			L	
REV	CHANGE	BY	DATE	ECN
L	DELETE PART 20005, 20207 - ADD 20497	R.T.N.	4/28/05	1065

34	10098	1	HEX BOLT (5/8" x 5")
35	10097	3	HEX BOLT (5/8" x 4 1/2")
36	10102	1	HEX BOLT (5/8" x 7")
37	10032	4	HEX BOLT (3/8" x 1 1/2")
38	10016	4	HEX BOLT (5/16" x 3/4")
39	10260	6	PLOW BOLT (1/2" x 1 1/2")
40	10185	5	LOCK WASHER (5/8" PLATED)
41	10166	5	LOCK NUT (5/8" PLATED)
42	10168	11	LOCK NUT (3/4" PLATED)
43	10186	4	LOCK WASHER (3/4" PLATED)
44	10175	9	LOCK NUT (3/8" PLATED)
45	10202	18	FLAT WASHER (3/8" PLATED)
46	10176	6	LOCK NUT (1/2" PLATED)
47	10201	4	FLAT WASHER (5/16" PLATED)
48	10181	5	LOCK WASHER (5/16" PLATED)
49	10173	1	NUT/WASHER (1 1/4")
50	10243	1	COTTER PIN (5/32" x 2")
51	21505	1	1060R DECK WELDMENT
52	10335	.76	RED PAINT
53	10336	.19	GEAR OIL
54	10646	.13	GREASE
55	20201	1	RIGHT A-FRAME BRACE WELD
56	20202	1	LEFT A-FRAME BRACE WELD
57	10154	1	5/16" LOCKNUT
58	10029	5	HEX BOLT (3/8" X 1-1/4")
59	10002	2	HEX BOLT (1/4" X 1")
60	10200	2	FLAT WASHER (1/4')
61	11850	1	WEBSITE DECAL
62	15852	2	DECAL - RED
63	15854	1	MANUAL HOLDER
64	15860	2	U-NUT (1/4")

All Dimensions in Inches Unless Otherwise Specified
Dimensions in [] are in Millimeters

Tolerances Unless Otherwise Specified
Fractional Dimensions ±1/16" Angular Dimensions ±1°
Decimal Dim. to Limits Shown All holes to be ⁺⁰/_{-1/32}

DRAWN BY	M.J.T.	4/8/99	EVH MANUFACTURING CO LORIS S.C.	
CHECKED BY				
MATERIAL	R.M.N. N/A	APPLICATION 1060R	OLD PART # N/A	
MANUFACTURED BY: EVH MANUFACTURING CO		DESCRIPTION ASSEMBLY DRAWING FOR 1060R		
DO NOT SCALE	A DWG SIZE	DWG. NO. 21403	SHT 1 OF 3	

DWG. NO.

21403

REV.

L

REV	CHANGE	BY	DATE	ECN
H	CHANGE PART NUMBER	T.R.M.	12/6/99	0688
I	CHANGE SERIAL # PLATE	T.R.M.	6/2/00	0792
J	CHANGE TO FLAT STRUT	T.R.M.	1/22/03	0937
K	UPDATE DRAWING	T.R.M.	10/23/03	0950
L	DELETE PART 20005, 20207 - ADD 20497	R.T.N.	4/28/05	1065

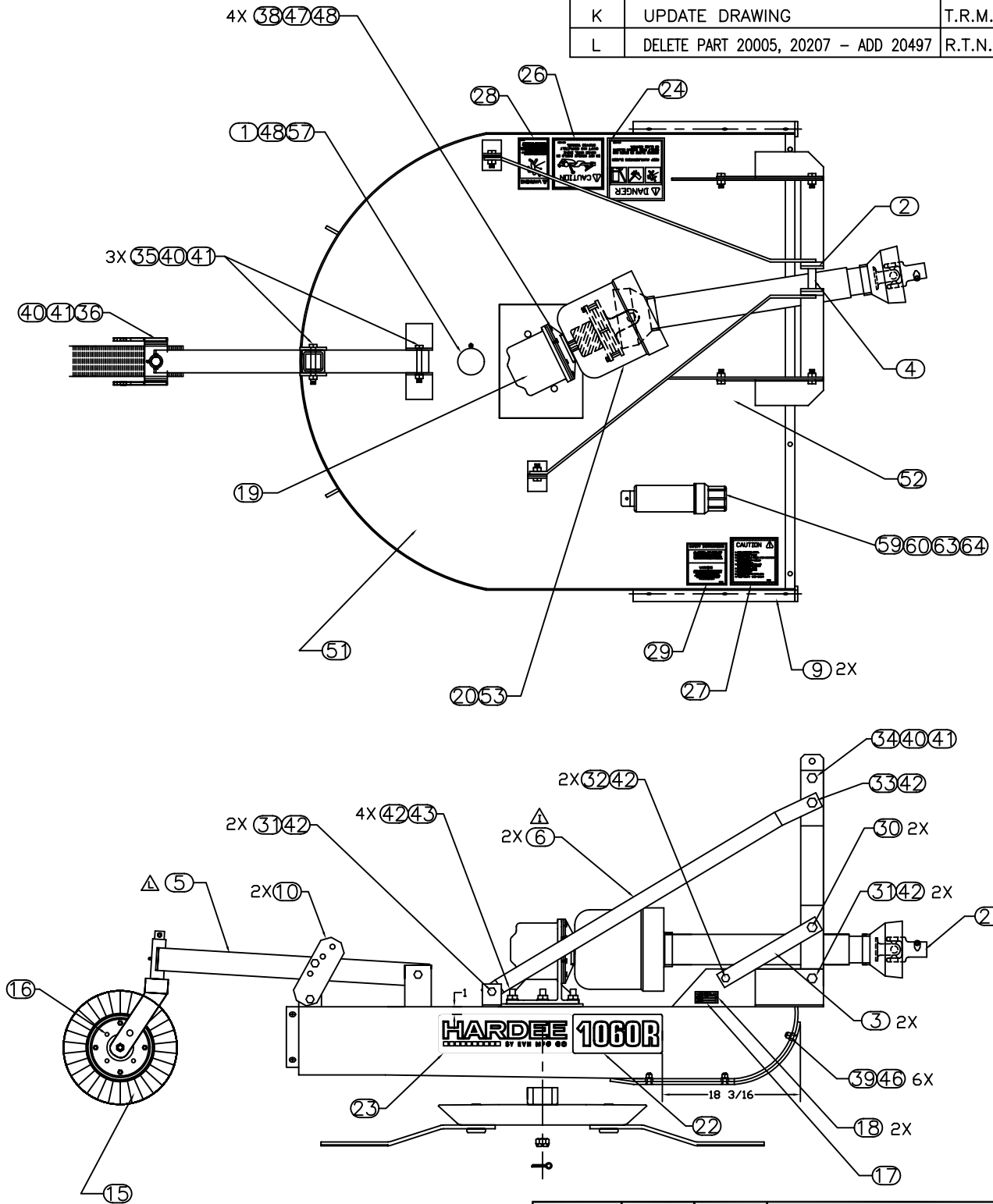

DRAWN BY	M.J.T.	4/8/99
CHECKED BY		
MATERIAL	R.M.N.	
MANUFACTURED BY: EVH MANUFACTURING CO		

EVH MANUFACTURING CO	
LORIS S.C.	
APPLICATION 1060R	OLD PART # ----
DESCRIPTION ASSEMBLY DRAWING FOR 1060R	
DO NOT SCALE	A DWG. NO. 21403
SHT 2 OF 3	

All Dimensions in Inches Unless Otherwise Specified
Dimensions in [] are in Millimeters

Tolerances Unless Otherwise Specified
Fractional Dimensions $\pm 1/16"$ Angular Dimensions $\pm 1"$
Decimal Dim. to Limits Shown All holes to be $\begin{matrix} +0 \\ -1/32 \end{matrix}$

DWG. NO.

21403

REV.

L

REV	CHANGE	BY	DATE	ECN
H	CHANGE PART NUMBER	T.R.M.	12/6/99	0688
I	CHANGE SERIAL # PLATE	T.R.M.	6/2/00	0792
J	CHANGE TO FLAT STRUT	T.R.M.	1/22/03	0937
K	UPDATE DRAWING	T.R.M.	10/23/03	0950
L	DELETE PART 20005, 20207 - ADD 20497	R.T.N.	4/28/05	1065

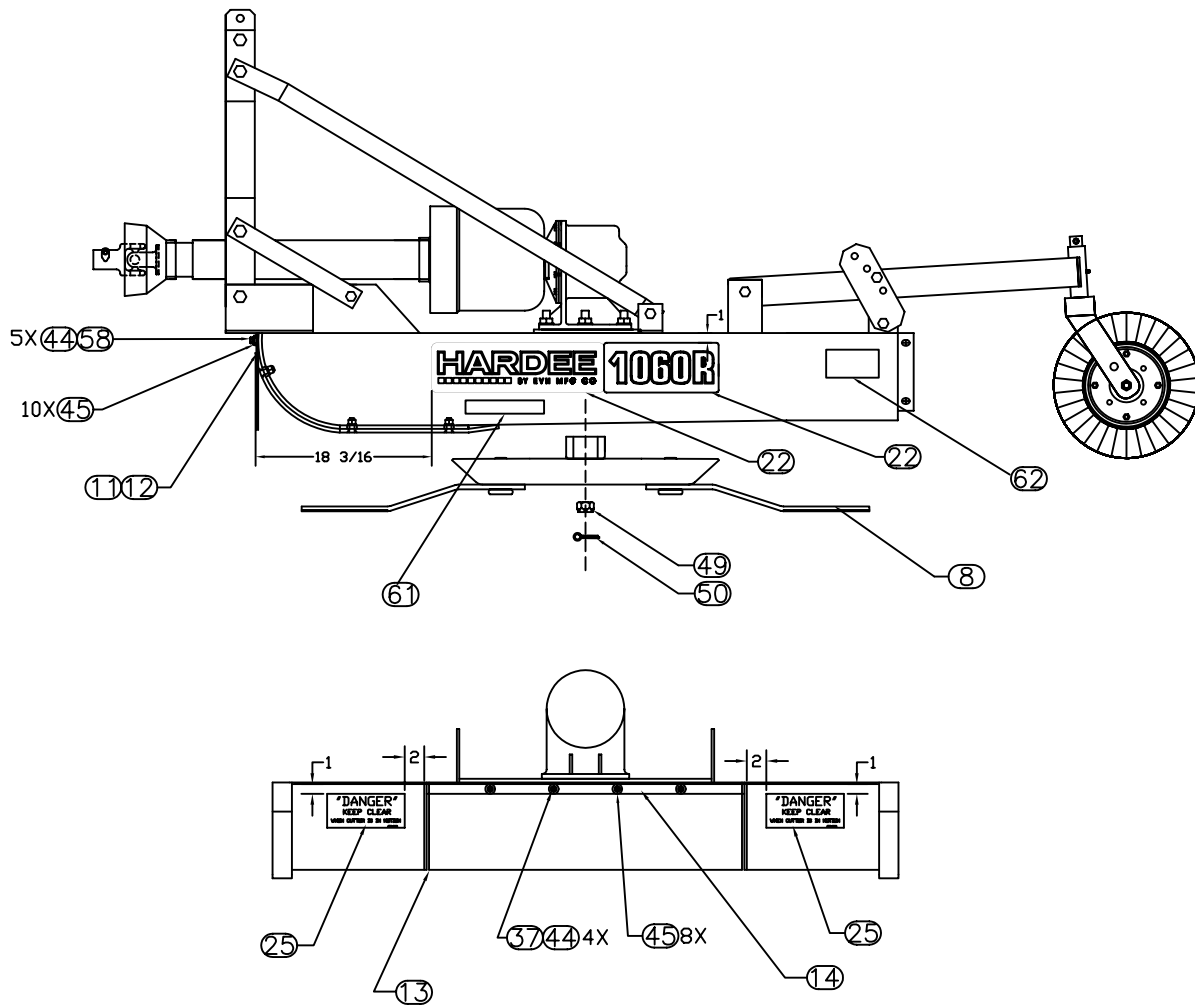

DRAWN BY	M.J.T.	4/8/99	EVH MANUFACTURING CO LORIS S.C.	
CHECKED BY				
MATERIAL		R.M.N.	APPLICATION	OLD PART #
MANUFACTURED BY:		EVH MANUFACTURING CO	1060R	----
			DESCRIPTION ASSEMBLY DRAWING FOR 1060R	
DO NOT SCALE	A	DWG. NO.	21403	
	DWG SIZE	SHT 3 OF 3		

All Dimensions in Inches Unless Otherwise Specified
Dimensions in [] are in Millimeters

Tolerances Unless Otherwise Specified
Fractional Dimensions $\pm 1/16"$ Angular Dimensions $\pm 1^\circ$
Decimal Dim. to Limits Shown All holes to be $^{+0}_{-1/32}$

ITEM NO.	PART NUMBER	QTY REQD.	NOMENCLATURE OR DESCRIPTION
1	20236	1	BLADE HOLDER WELDMENT
2	10313	2	BLADE BOLT GR.8
3	10426	2	UP LIFT BLADE
4	10311	2	BLADE BOLT NUT GR.8
5	10312	2	BLADE BOLT LOCKWASHER GR.8

DWG. NO.			REV.	
20298			B	
REV	CHANGE	BY	DATE	ECN
IR	INITIAL RELEASE	M.J.T	11/4/97	----
A	CREATE VIEWS	M.J.T	6/10/98	0381
B	CHANGE BLADE PART NUMBER	M.J.T	11/30/98	0533

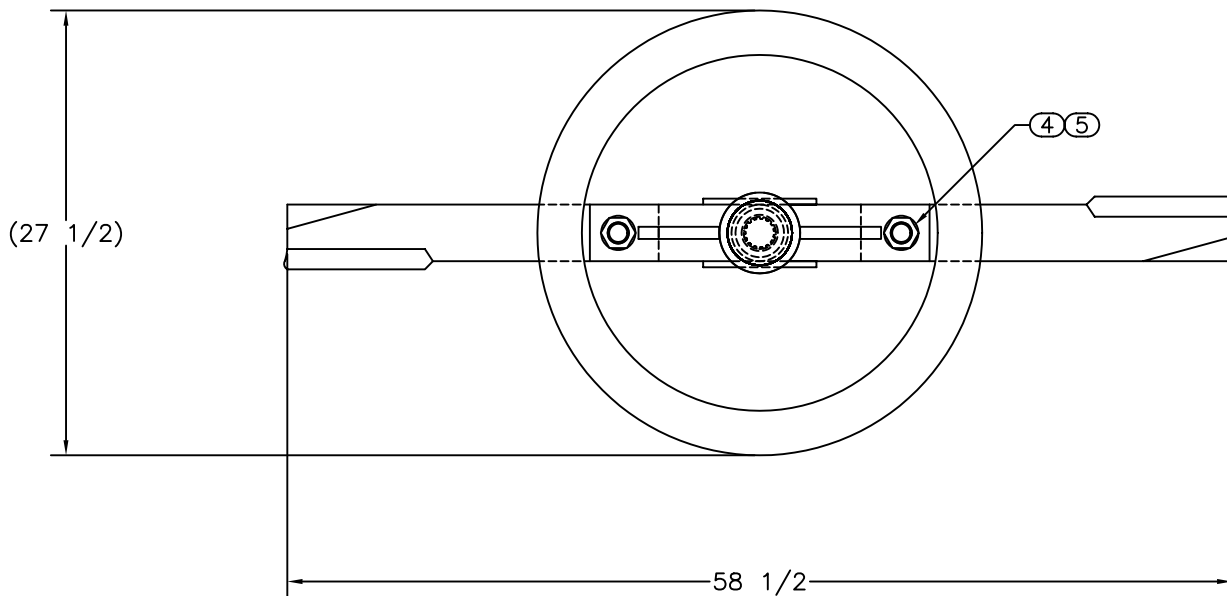
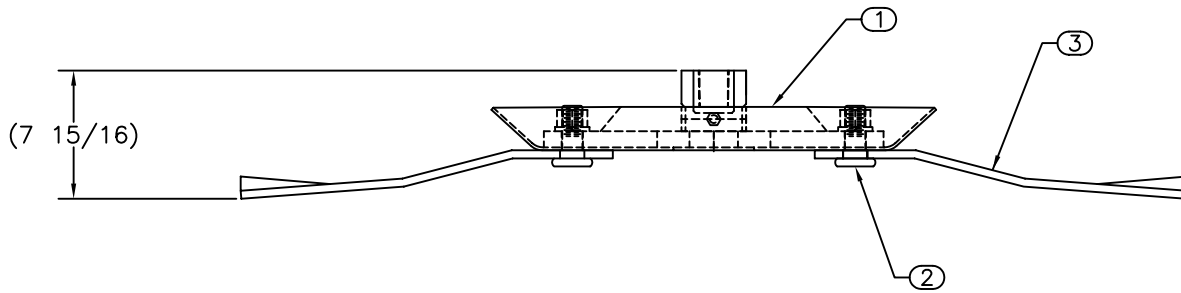

DRAWN BY	M.J.T	6/10/98
CHECKED BY		
MATERIAL	R.M.N.	
MANUFACTURED BY HARDEE WILLIAMS		

HARDEE BY EVH MFG. CO. LORIS S.C.	
APPLICATION	OLD PART #
DESCRIPTION BLADE HOLDER SUBASSEMBLY	
DO NOT SCALE	DWG. NO. 20298
A	DWG SIZE

All Dimensions in Inches Unless Otherwise Specified
Dimensions in [] are in Millimeters

Tolerances Unless Otherwise Specified
Fractional Dimensions $\pm 1/16"$ Angular Dimensions $\pm 1^\circ$
Decimal Dim. to Limits Shown All holes to be $\begin{matrix} +0 \\ -1/32 \end{matrix}$

10327 Gearbox

(90H.P. Gearbox 1: 1.47 Ratio)

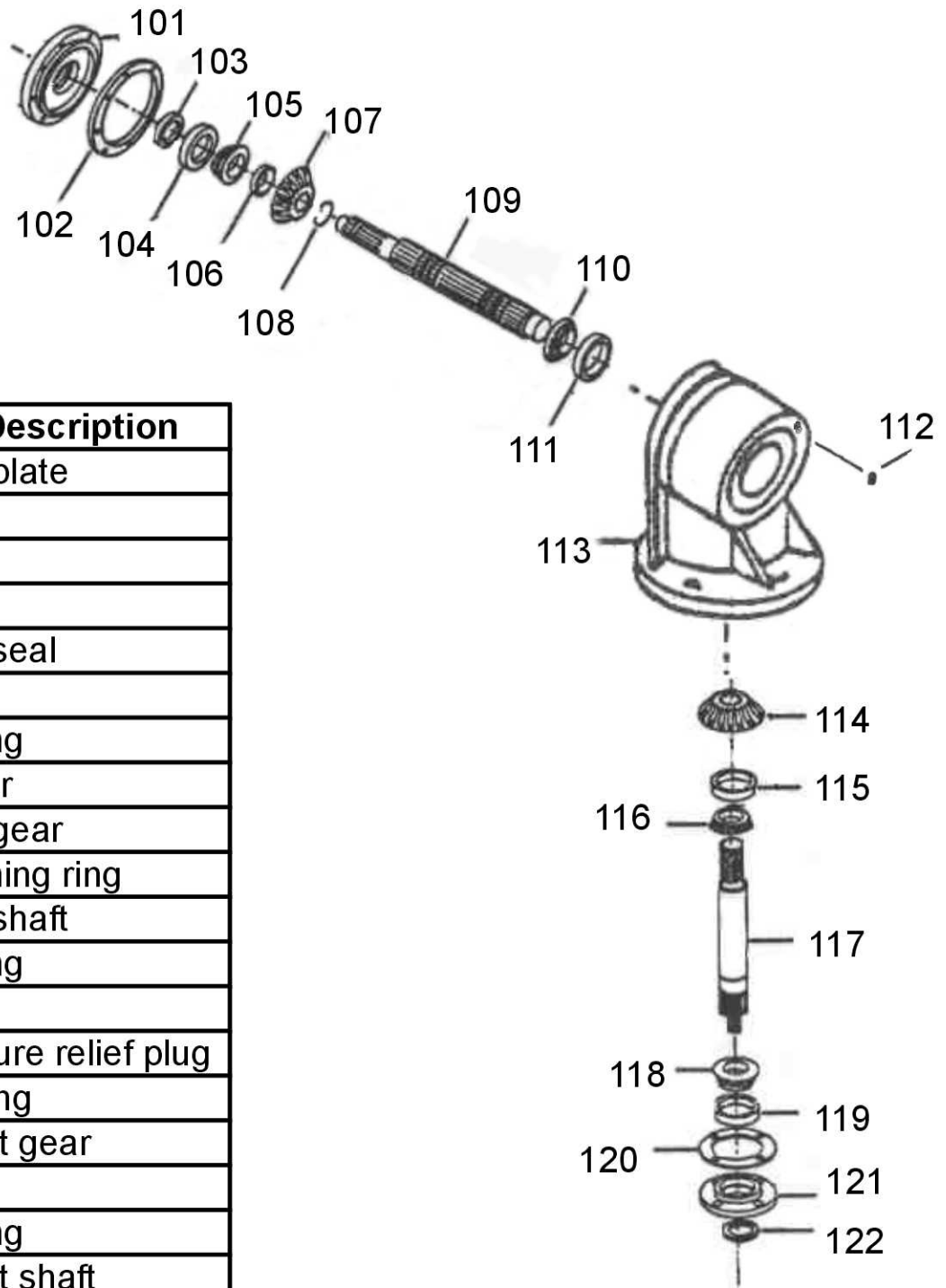

Key #	Part No.	Part Description
101	15768	Face plate
102	15732	Shim
	15733	Shim
	15734	Shim
103	15715	Input seal
104	11240	Cup
105	11241	Bearing
106	15606	Spacer
107	10683	Input gear
108	10353	Retaining ring
109	15602	Input shaft
110	11241	Bearing
111	11240	Cup
112	15664	Pressure relief plug
113	11516	Housing
114	10682	Output gear
115	11243	Cup
116	10352	Bearing
117	15600	Output shaft
118	10352	Bearing
119	11242	Cup
120	15706	Shim
121	15705	Bottom cover
122	10354	Output seal

11566 Driveshaft

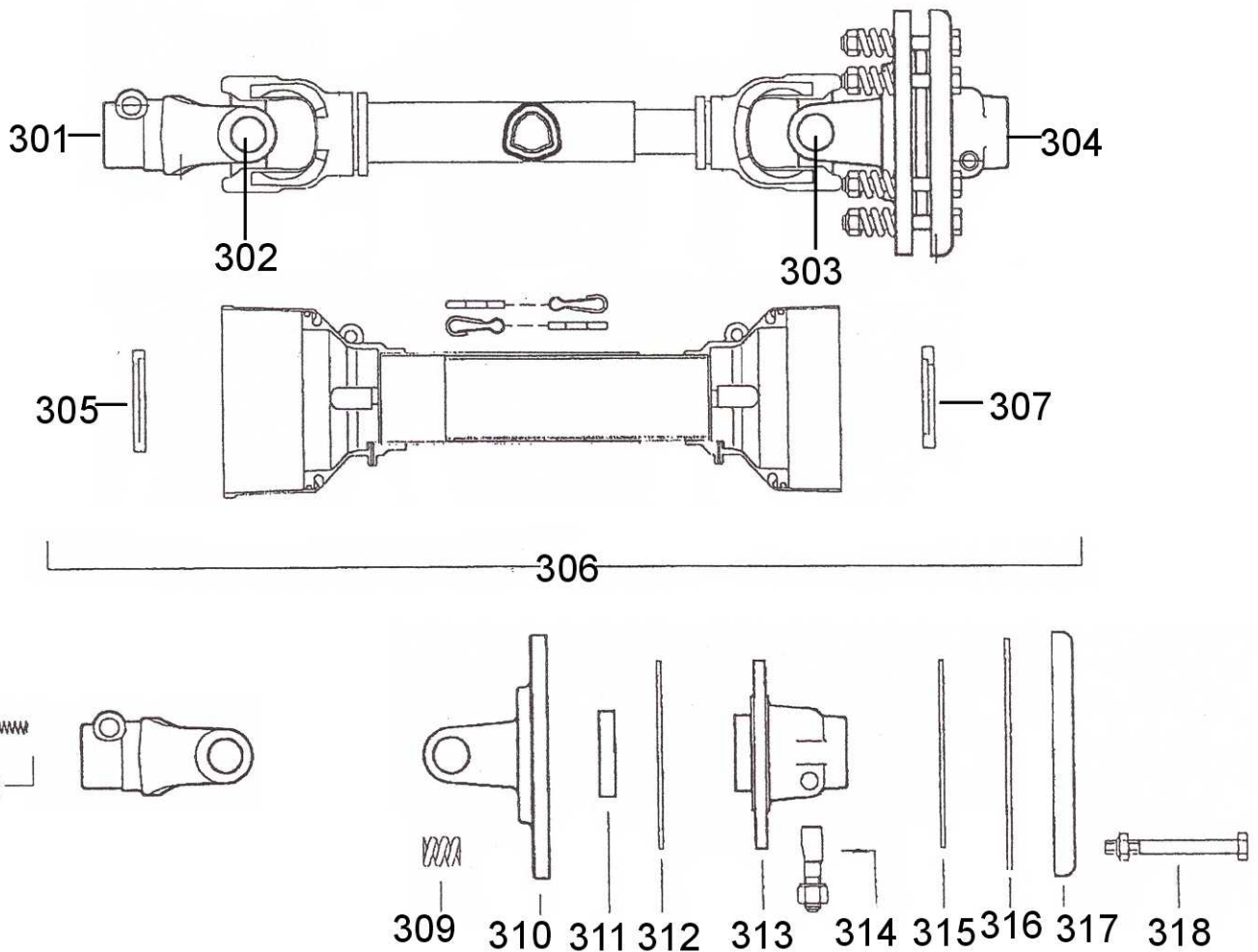

Key #	Part No.	Description	Key #	Part No.	Description
301	15658	Yoke, Tractor end	310	15798	Flange yoke
302	15629	Cross kit	311	15562	Bushing
303	15629	Cross kit	312	11204	Clutch facing
304	15630	Clutch, complete	313	15633	Center hub
305	15795	Shield bearing	314	15615	Wedge bolt
306	15797	Shield kit complete	315	11204	Clutch facing
307	15796	Shield bearing	316	15563	Inner plate
308	15579	Push pin complete	317	15799	Pressure plate
309	15561	Spring	318	15794	Clutch bolt