

Item	Part Number	Qty.	Description
1	10078	4	1/2 X 4 1/2 Hex Bolt (Gr.5 Plated)
2	10097	2	Hex Bolt 5/8"-11 x 4 1/2" gr.5 Plated
3	10166	2	Lock Nut 5/8"-11 plated
4	10176	24	1/2" Locknut (Gr.5 Plated)
5	10307	2	CATEGORY I HITCH PIN
6	10335	1	Hardee Red Paint - (Not Shown)
7	10855	8	U-Bolt, PLATED Sq 3-1/2" x 4"x 1/2" Dia
8	11032	2	DECAL, SMALL HARDEE LOGO
9	15211	2	D-10-1618 Model Decal
10	15464	4	Tubing Insert, 3" X 2" X 10 Gage
11	60505	4	D-10-1618 Gang Assembly
12	60510	1	D-10 MAIN FRAME WELDMENT
13	60519	2	Gang Beam (22")
14	60520	2	Gang Beam (30")
15	60522	2	A-FRAME BRACE
16	60527	1	Gang Pin Rear Weldment
17	60530	1	Gang Pin Front Weldment
18	60536	1	D-10 A-FRAME WELDMENT
19	60539	4	GANG TIE PLATE WELDMENT
20	11636-ITEM_4	1	Toe Crush Decal (4 X 1.25)
21	11636-ITEM_5	1	Crushing Hazard Decal (3 X 3)

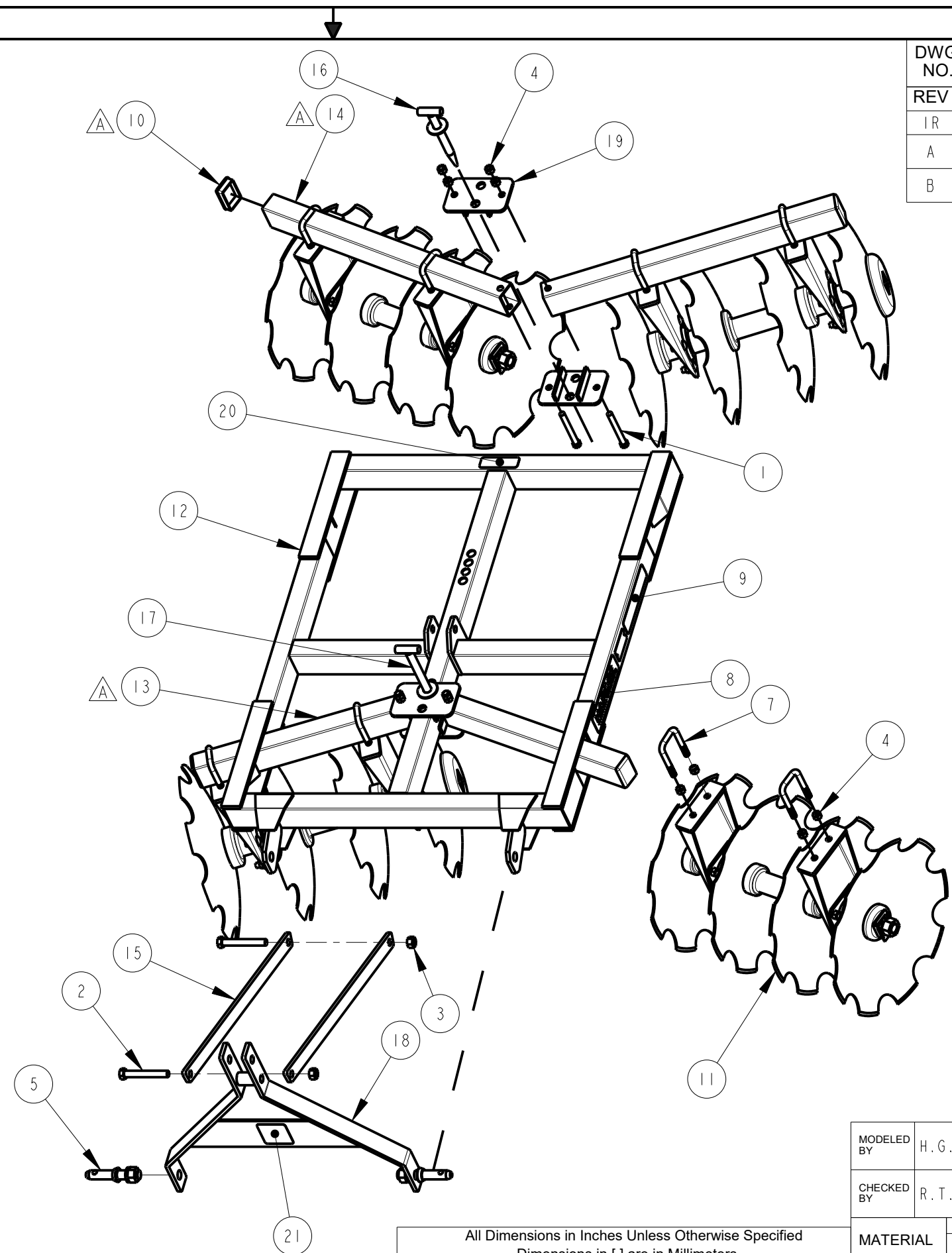

DWG. NO.	60501		REV.	B	
REV	CHANGE	BY	DATE	ECN	
IR	INITIAL RELEASE	J.O.C.	8/12/02	---	
A	Removed Beam Weldments Added Tubing Inserts & Beams	J.O.C.	4/4/05	1057	
B	WAS 2 SHEETS. SHOWED A-FRAME QUICK HITCH MODIFICATIONS.	M.J.Z.	7/24/20	1775	

All Dimensions in Inches Unless Otherwise Specified  
Dimensions in [ ] are in Millimeters  
Tolerance Unless Otherwise Specified  
Fractional Dimensions: 1/16" Angular Dimensions: 1°  
Decimal Dim. to Limits Shown All Holes to be +0 -1/32"

MODELED BY	H.G.S.	8/12/02	<b>HARDEE BY EVH MFG. CO. LORIS S.C.</b>	
CHECKED BY	R.T.N.	9/9/02		
MATERIAL	R.M.N.	N/A	DESCRIPTION	SHEET 1 of 1
Manufactured By: EVH Mfg. Co., LLC			D-10-1618 ASSEMBLY	
DO NOT SCALE	B	DWG. NO.	60501	
	DWG. SIZE			