

Item	Part Number	Qty.	Description
1	10072	4	Hex Bolt 1/2 x 1 1/2 gr.5 plated
2	10136	1	Hex Bolt 1 x 6 1/2 gr.5 plated
3	10166	9	Lock Nut 5/8"-11 plated
4	10171	1	Lock Nut 1" plated
5	10184	4	Lockwasher 1/2 plated
6	10207	4	Flatwasher, 1" plated
7	10252	1	Cotter Pin 3/16" X 2" Plated
8	10262	9	Plow Bolt 5/8 x 1 1/2 Gr.5 Plated
9	10335	1	Hardee Red Paint - (Not Shown)
10	10339	2	Pop Rivet
11	10343	1	Ratchet Jack
12	10346	2	3 pt. Snap Pin (Lynch Pin)
13	10390	1	Clip Pin (1/8 x 2)
14	10391	6	Clip Pin (Hairpin) 3/16 X 3-1/4"
15	10393	1	Universal Clip Pin
16	10433	1	84 Cutting Edge
17	10445	1	3/4 Dia. Bent Hitch Pin
18	10446	4	Clevis Pin (1 X 2 5/8)
19	10447	1	Clevis Pin (1 X 5)
20	10464	2	Category I and II Hitch Pin
21	11032	2	Small Hardee Logo Decal
22	11131	1	Large Hardee Logo Decal
23	11413	1	Castle Nut (1) Gr.5 Plated Fine Thread
24	11609	1	ABH-84 I.D. DECAL (LARGE)
25	11636	1	Safety Decal Sheet
26	11636-1	1	WARNING DECAL (KIT 11636)
27	11636-2	1	WARNING DECAL (KIT 15845)
28	11636-3	3	WARNING DECAL (KIT 11636)
29	11636-4	2	WARNING DECAL (KIT 11636)
30	11636-5	2	DANGER DECAL (KIT 11636)
31	11636-6	1	WARNING DECAL (KIT 11636)
32	11727	1	Serial Number Plate
33	11850	1	Web Site Decal
34	40035	1	Rear Blade Front Frame Weldment
35	40036	1	Rear Blade Center Frame Weldment
36	40037	1	Rear Blade Carriage Housing Weldment
37	40058	1	Outer Pivot Cap
38	40086	1	ABH84 REAR BLADE WELDMENT
39	40227	1	Pivot Bolt Weldment
40	40308	1	ABH Stand Weldment

## ABH-84 Rear Blade Complete

DWG. NO.	40033		REV.		H
REV	CHANGE	BY	DATE	ECN	
G	Weldment updated (Complete machine created in Creo 2.0)	T.B.B.	8/25/15	1626	
H	Replace stabilizer with Ratchet Jack	C.K.N.	6/15/16	1658	

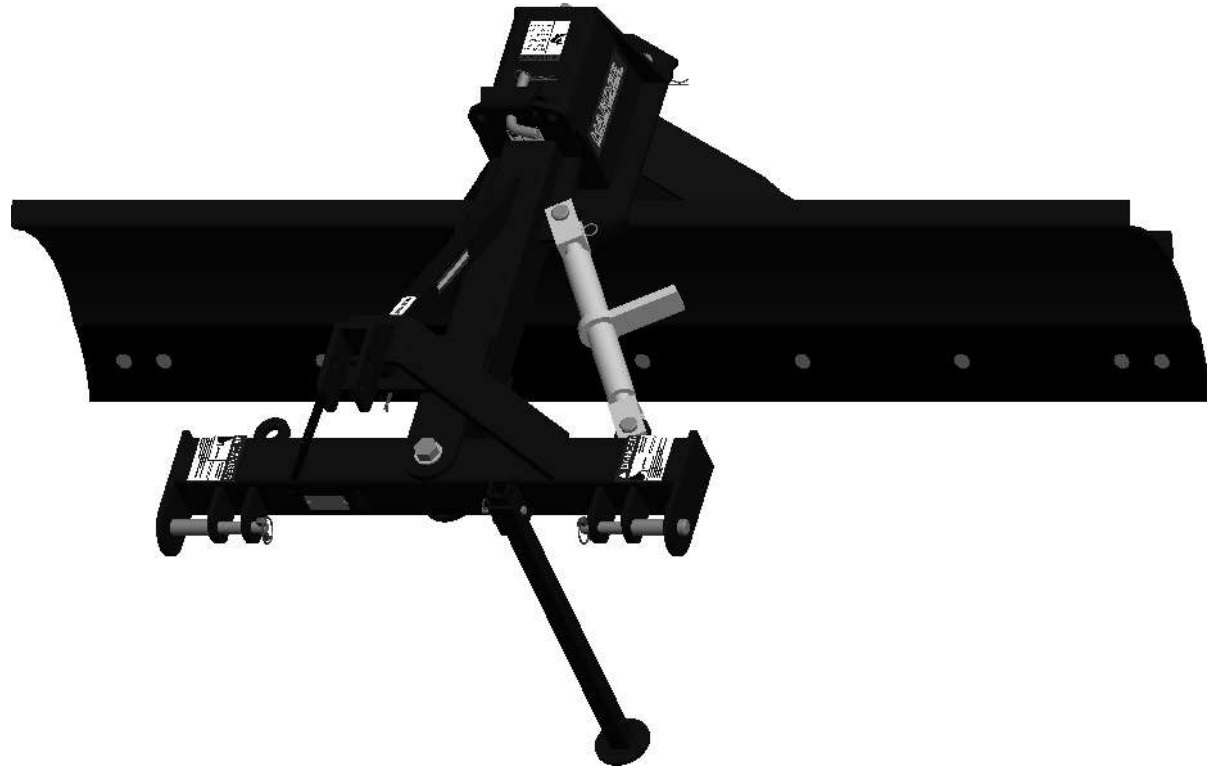

MODELED BY	JIM CREEL	N/A	<b>HARDEE BY EVH MFG. CO. LORIS S.C.</b>		
DRAWN BY	T.B.B.	8/25/15			
MATERIAL		R.M.N. N/A	DESCRIPTION	SHEET 1 of 3	
Manufactured By: EVH Mfg. Co., LLC			ABH-84 Rear Scraper	DO NOT SCALE	DWG. NO. 40033

All Dimensions in Inches Unless Otherwise Specified  
Dimensions in [ ] are in Millimeters

**Tolerance Unless Otherwise Specified**

Fractional Dimensions ± 1/16"	Angular Dimensions ± 1°
Decimal Dim. to Limits Shown	All Holes to be +0 -1/32"

Item	Part Number	Qty.	Description
1	10072	4	Hex Bolt 1/2 x 1 1/2 gr.5 plated
2	10136	1	Hex Bolt 1 x 6 1/2 gr.5 plated
3	10166	9	Lock Nut 5/8"-11 plated
4	10171	1	Lock Nut 1" plated
5	10184	4	Lockwasher 1/2 plated
6	10207	4	Flatwasher, 1" plated
7	10252	1	Cotter Pin 3/16" X 2" Plated
8	10262	9	Plow Bolt 5/8 x 1 1/2 Gr.5 Plated
9	10335	1	Hardee Red Paint - (Not Shown)
10	10339	2	Pop Rivet
11	10343	1	Ratchet Jack
12	10346	2	3 pt. Snap Pin (Lynch Pin)
13	10390	1	Clip Pin (1/8 x 2)
14	10391	6	Clip Pin (Hairpin) 3/16 X 3-1/4"
15	10393	1	Universal Clip Pin
16	10433	1	84 Cutting Edge
17	10445	1	3/4 Dia. Bent Hitch Pin
18	10446	4	Clevis Pin (1 X 2 5/8)
19	10447	1	Clevis Pin (1 X 5)
20	10464	2	Category I and II Hitch Pin
21	11032	2	Small Hardee Logo Decal
22	11131	1	Large Hardee Logo Decal
23	11413	1	Castle Nut (1) Gr.5 Plated Fine Thread
24	11609	1	ABH-84 I.D. DECAL (LARGE)
25	11636	1	Safety Decal Sheet
26	11636-1	1	WARNING DECAL (KIT 11636)
27	11636-2	1	WARNING DECAL (KIT 15845)
28	11636-3	3	WARNING DECAL (KIT 11636)
29	11636-4	2	WARNING DECAL (KIT 11636)
30	11636-5	2	DANGER DECAL (KIT 11636)
31	11636-6	1	WARNING DECAL (KIT 11636)
32	11727	1	Serial Number Plate
33	11850	1	Web Site Decal
34	40035	1	Rear Blade Front Frame Weldment
35	40036	1	Rear Blade Center Frame Weldment
36	40037	1	Rear Blade Carriage Housing Weldment
37	40058	1	Outer Pivot Cap
38	40086	1	ABH84 REAR BLADE WELDMENT
39	40227	1	Pivot Bolt Weldment
40	40308	1	ABH Stand Weldment

DWG. NO.	40033			REV.	H
REV	CHANGE	BY	DATE	ECN	
G	Weldment updated (Complete machine created in Creo 2.0)	T.B.B.	8/25/15	1626	
H	Replace stabilizer with Ratchet Jack	C.K.N.	6/15/16	1658	

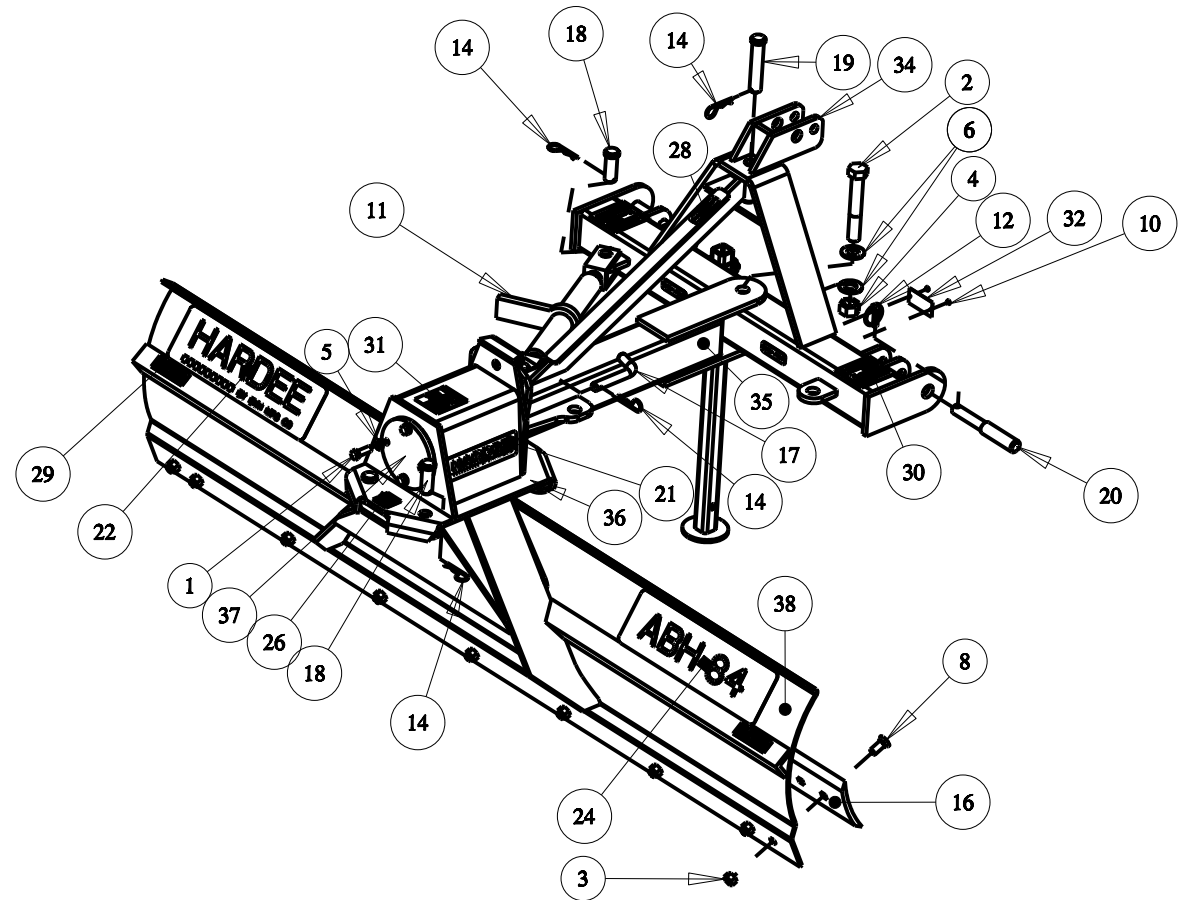

All Dimensions in Inches Unless Otherwise Specified  
Dimensions in [ ] are in Millimeters  
Tolerance Unless Otherwise Specified  
Fractional Dimensions ± 1/16"  
Decimal Dim. to Limits Shown

Angular Dimensions ± 1°  
All Holes to be +0 -1/32"

MODELED BY	JIM CREEL	N/A	<b>HARDEE BY  EVH MFG. CO.  LORIS S.C.</b>	
DRAWN BY	T.B.B.	8/25/15		
MATERIAL	R.M.N. N/A		DESCRIPTION	SHEET 2 of 3
Manufactured By: EVH Mfg. Co., LLC			ABH-84 Rear Scraper	
DO NOT SCALE	A DWG. SIZE	DWG. NO.	40033	

Item	Part Number	Qty.	Description
1	10072	4	Hex Bolt 1/2 x 1 1/2 gr.5 plated
2	10136	1	Hex Bolt 1 x 6 1/2 gr.5 plated
3	10166	9	Lock Nut 5/8"-11 plated
4	10171	1	Lock Nut 1" plated
5	10184	4	Lockwasher 1/2 plated
6	10207	4	Flatwasher, 1" plated
7	10252	1	Cotter Pin 3/16" X 2" Plated
8	10262	9	Plow Bolt 5/8 x 1 1/2 Gr.5 Plated
9	10335	1	Hardee Red Paint - (Not Shown)
10	10339	2	Pop Rivet
11	10343	1	Ratchet Jack
12	10346	2	3 pt. Snap Pin (Lynch Pin)
13	10390	1	Clip Pin (1/8 x 2)
14	10391	6	Clip Pin (Hairpin) 3/16 X 3-1/4"
15	10393	1	Universal Clip Pin
16	10433	1	84 Cutting Edge
17	10445	1	3/4 Dia. Bent Hitch Pin
18	10446	4	Clevis Pin (1 X 2 5/8)
19	10447	1	Clevis Pin (1 X 5)
20	10464	2	Category I and II Hitch Pin
21	11032	2	Small Hardee Logo Decal
22	11131	1	Large Hardee Logo Decal
23	11413	1	Castle Nut (1) Gr.5 Plated Fine Thread
24	11609	1	ABH-84 I.D. DECAL (LARGE)
25	11636	1	Safety Decal Sheet
26	11636-1	1	WARNING DECAL (KIT 11636)
27	11636-2	1	WARNING DECAL (KIT 15845)
28	11636-3	3	WARNING DECAL (KIT 11636)
29	11636-4	2	WARNING DECAL (KIT 11636)
30	11636-5	2	DANGER DECAL (KIT 11636)
31	11636-6	1	WARNING DECAL (KIT 11636)
32	11727	1	Serial Number Plate
33	11850	1	Web Site Decal
34	40035	1	Rear Blade Front Frame Weldment
35	40036	1	Rear Blade Center Frame Weldment
36	40037	1	Rear Blade Carriage Housing Weldment
37	40058	1	Outer Pivot Cap
38	40086	1	ABH84 REAR BLADE WELDMENT
39	40227	1	Pivot Bolt Weldment
40	40308	1	ABH Stand Weldment

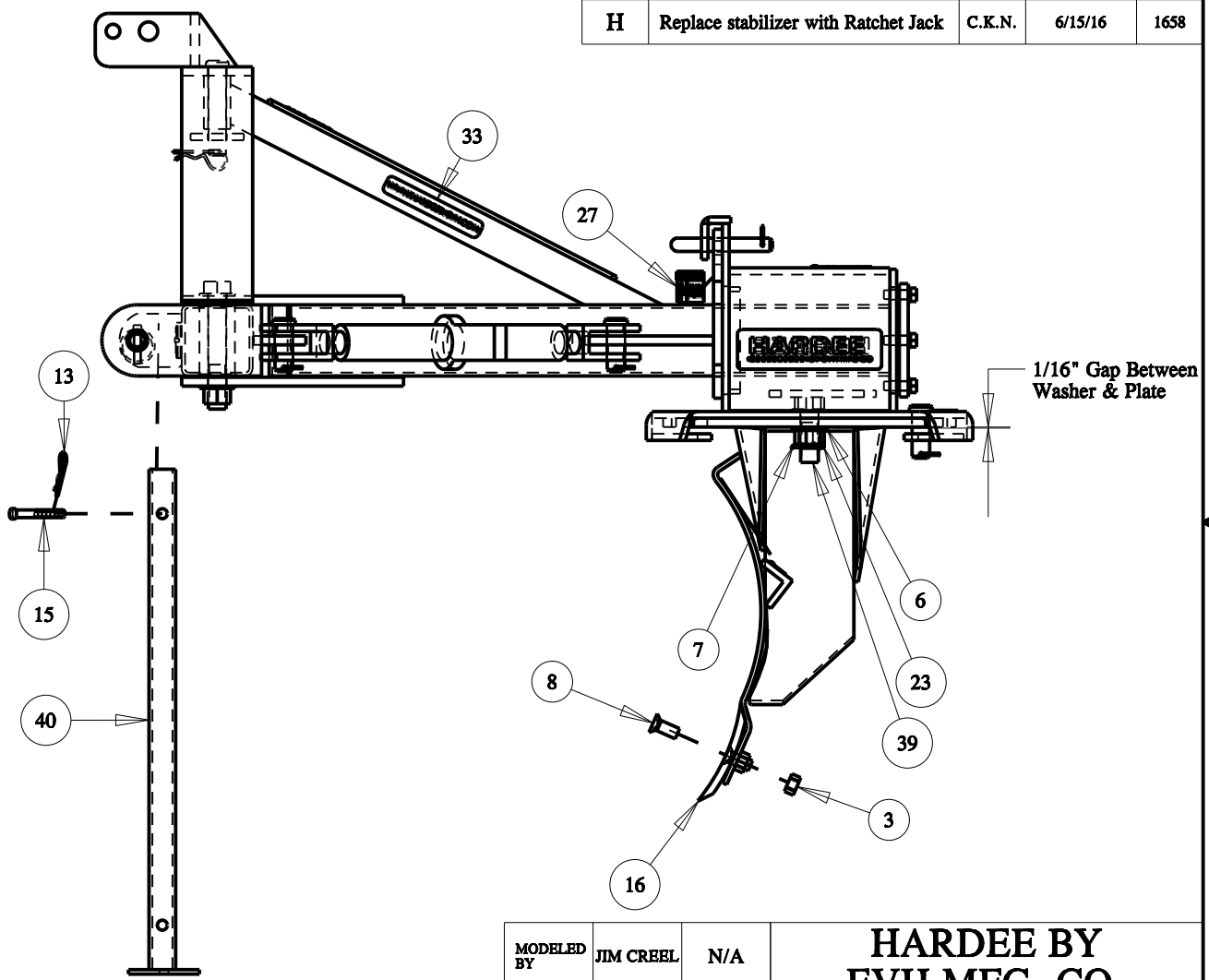

DWG. NO.	40033			REV.	H
REV	CHANGE	BY	DATE	ECN	
G	Weldment updated (Complete machine created in Creo 2.0)	T.B.B.	8/25/15	1626	
H	Replace stabilizer with Ratchet Jack	C.K.N.	6/15/16	1658	

All Dimensions in Inches Unless Otherwise Specified Dimensions in [ ] are in Millimeters		MODELED BY JIM CREEL N/A		<b>HARDEE BY EVH MFG. CO.</b> LORIS S.C.	
Tolerance Unless Otherwise Specified		DRAWN BY T.B.B. 8/25/15			
Fractional Dimensions ± 1/16" Decimal Dim. to Limits Shown		Angular Dimensions ± 1° All Holes to be +0 -1/32"		ABH-84 Rear Scraper	
		MATERIAL R.M.N. N/A		DO NOT SCALE	DWG. NO. 40033
		Manufactured By: EVH Mfg. Co., LLC		A DWG. NO.	