

**ADD THIS REVISION AT NEXT  
DRAWING CHANGE**

---

See ECR Change #0980 for Details  
Add Qty. (1) Each 15852, 15853

DWG. NO.			REV.	
30096			F	
REV	CHANGE	BY	DATE	ECN
IR	INITIAL RELEASE	W.E.S.	9/26/98	---
A	CHANGE PART #	T.O.B.	1/12/00	0734
B	DELETE PART #	T.R.M.	1/31/00	0743
C	ADD RED PAINT	T.O.B.	4/5/00	0781
D	CHANGE PART NUMBER	T.O.B.	4/13/00	0766
E	CHANGE SERIAL # PLATE	T.R.M.	6/7/00	0792
F	PART # 13355 ADDED TO DRAWING	T.B.B.	4/23/14	1566

DRAWN BY	W.E.S.	9/26/98	<b>HARDEE BY EVH MFG. CO. LORIS S.C.</b>	
CHECKED BY				
MATERIAL	R.M.N.		APPLICATION	OLD PART #
MANUFACTURED BY HARDEE MFG. CO., LLC			L-65	----
			DESCRIPTION FRAME AND TANK COMPLETE FOR L-65 SPRAYER	
DO NOT SCALE	A	DWG. NO.	SHEET 1 OF 3	
	DWG SIZE	30096		

All Dimensions in Inches Unless Otherwise Specified  
Dimensions in [ ] are in Millimeters

Tolerances Unless Otherwise Specified  
Fractional Dimensions  $\pm 1/16"$  Angular Dimensions  $\pm 1^\circ$   
Decimal Dim. to Limits Shown All holes to be  $^{+0}_{-0.015}$

ITEM NO.	PART NUMBER	QTY REQD.	NOMENCLATURE OR DESCRIPTION
1	30001	1	FRAME WELDMENT
2	15477	42"	2" WEBBING STRAP
3	16149	2	HEX BOLT (3/8 X 2-1/2") (FT)
4	10202	8	FLAT WASHER (3/8)
5	10175	2	LOCK NUT (3/8)
6	13532	2	HOSE CLAMP - #12
7	13355	3	3/4 MNPT X 3/4 HB ELBOW
8	10816	2	3/4 DBL THRD TANK FITTING
9	11727	1	SERIAL NUMBER PLATE
10	10800	4	SMALL O-RING/VITON
11	10799	3	SMALL NUT TANK FITTING
12	13319	1	3/4 NPT X 3/4 HB
13	10822	1	3/4 NPT PIPE NIPPLE
14	10762	1	65 GA. VERT. POLY TANK
15	12344	1	3/4 FNPT STRAINER
16	13029	1	AGITATOR
17	11016	1	SPRAYER CHECK LIST DECAL
18	11096	1	HARDEE EAGLE DECAL
19	10797	30"	3/4 CLEAR HOSE
20	13007	1	3/4 FNPT BALL VALVE
21	10390	1	CLIP PIN
22	10346	2	RING PIN
23	10445	1	PIN
24	10339	2	RIVET FOR SERIAL # PLATE
25	10335	.09	RED PAINT

DWG. NO.			REV.	
30096			F	
REV	CHANGE	BY	DATE	ECN
A	CHANGE PART #	T.O.B.	1/12/00	0734
B	DELETE PART #	T.R.M.	1/31/00	0743
C	ADD RED PAINT	T.O.B.	4/5/00	0781
D	CHANGE PART NUMBER	T.O.B.	4/13/00	0766
E	CHANGE SERIAL # PLATE	T.R.M.	6/7/00	0792
F	PART # 13355 ADDED TO DRAWING	T.B.B.	4/23/14	1566

All Dimensions in Inches Unless Otherwise Specified  
Dimensions in [ ] are in Millimeters

Tolerances Unless Otherwise Specified  
Fractional Dimensions ±1/16" Angular Dimensions ±1°  
Decimal Dim. to Limits Shown All holes to be  $\begin{matrix} +0 \\ -0.015 \end{matrix}$

DRAWN BY	W.E.S.	9/26/98	<b>HARDEE BY  EVH MFG. CO.  LORIS S.C.</b>	
CHECKED BY				
MATERIAL	R.M.N.		APPLICATION L-65	OLD PART # ----
MANUFACTURED BY HARDEE MFG. CO., LLC			DESCRIPTION FRAME AND TANK COMPLETE FOR L-65 SPRAYER	
DO NOT SCALE	A	DWG. NO.	SHEET 1 OF 3	
DWG SIZE		30096		

DWG. NO.

30096

REV.

F

REV	CHANGE	BY	DATE	ECN
A	CHANGE PART #	T.O.B.	1/12/00	0734
B	DELETE PART #	T.R.M.	1/31/00	0743
C	ADD RED PAINT	T.O.B.	4/5/00	0781
D	CHANGE PART NUMBER	T.O.B.	4/13/00	0766
E	CHANGE SERIAL # PLATE	T.R.M.	6/7/00	0792
F	PART # 13355 ADDED TO DRAWING	T.B.B.	4/23/14	1566

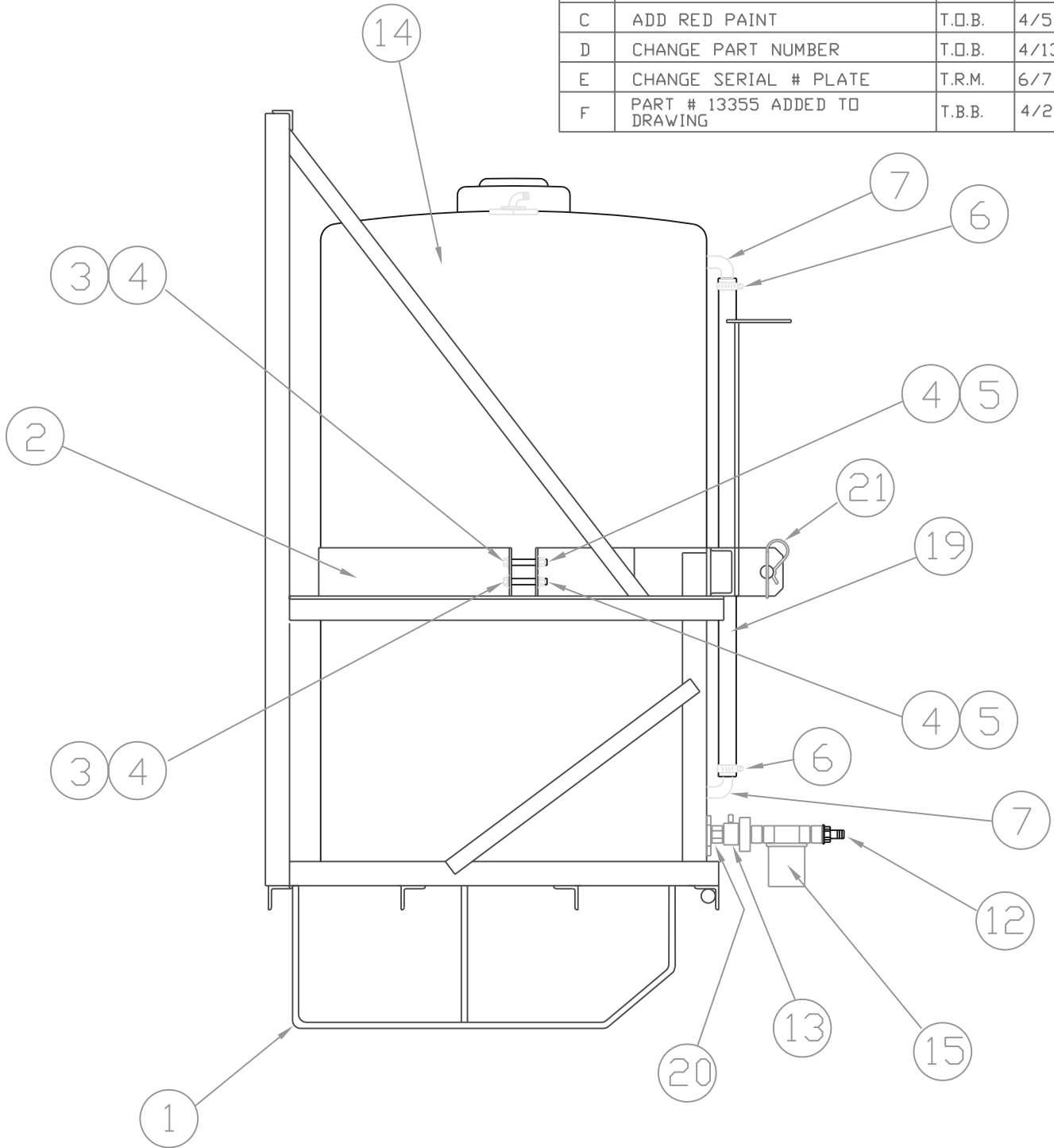

SIDE VIEW

All Dimensions in Inches Unless Otherwise Specified  
 Dimensions in [ ] are in Millimeters

Tolerances Unless Otherwise Specified  
 Fractional Dimensions  $\pm 1/16"$  Angular Dimensions  $\pm 1^\circ$   
 Decimal Dim. to Limits Shown All holes to  $b_{+0}^{-1/32}$

DRAWN BY	W.E.S.	9/26/98
CHECKED BY		
MATERIAL	R.M.N.	
MANUFACTURED BY HARDEE MFG. CO., LLC		

**HARDEE BY  
 EVH MFG. CO.  
 LORIS S.C.**

APPLICATION	OLD PART #
L-65	----
DESCRIPTION FRAME AND TANK COMPLETE FOR L-65 SPRAYER	
DO NOT SCALE	DWG. NO.
A	30096
DWG SIZE	SHEET 2 OF 3

DWG. NO.

30096

REV.

F

REV	CHANGE	BY	DATE	ECN
A	CHANGE PART #	T.O.B.	1/12/00	0734
B	DELETE PART #	T.R.M.	1/31/00	0743
C	ADD RED PAINT	T.O.B.	4/5/00	0781
D	CHANGE PART NUMBER	T.O.B.	4/13/00	0766
E	CHANGE SERIAL # PLATE	T.R.M.	6/7/00	0792
F	PART # 13355 ADDED TO DRAWING	T.B.B.	4/23/14	1566

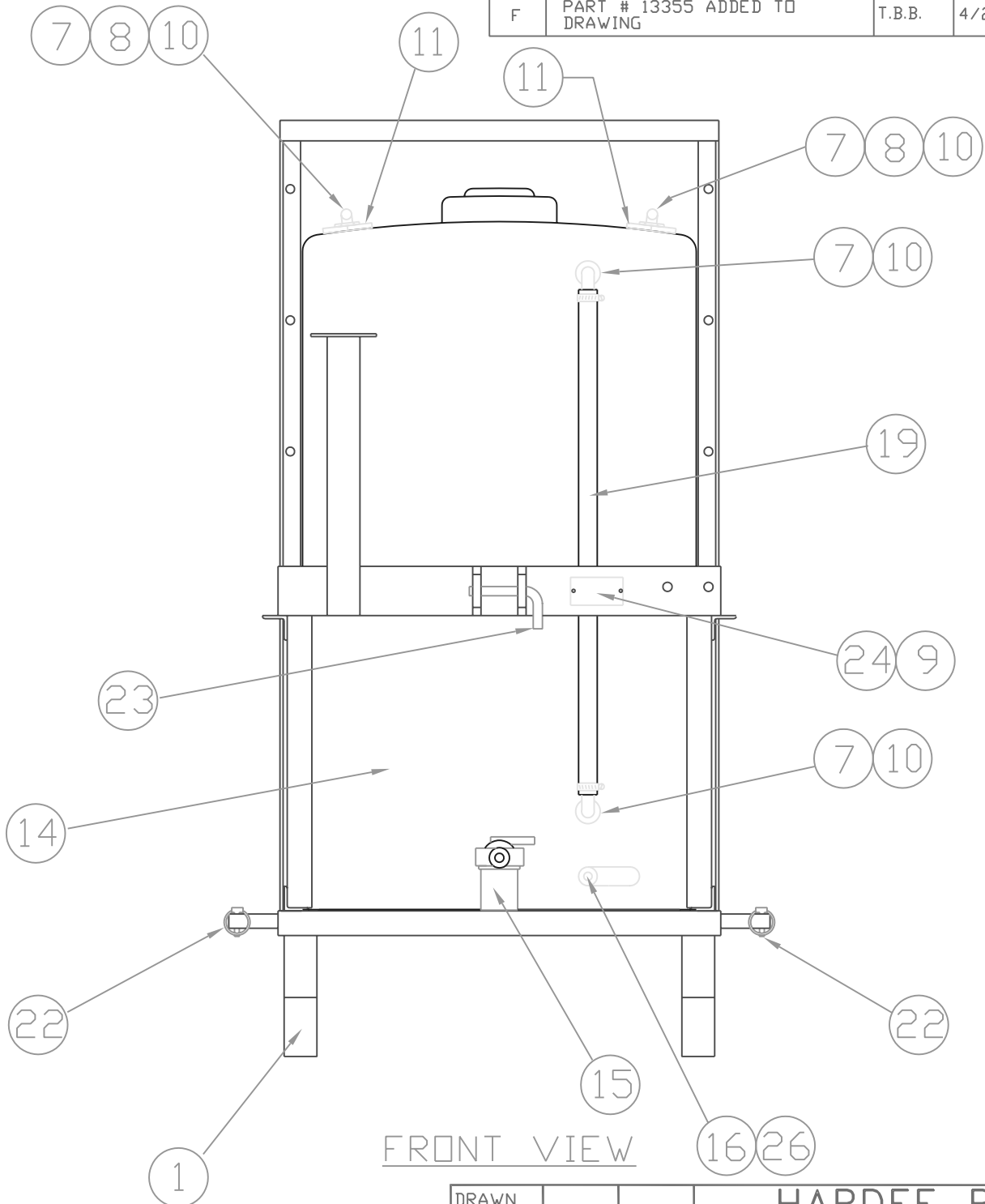

FRONT VIEW

DRAWN BY	W.E.S.	9/26/98
CHECKED BY		

**HARDEE BY  
EVH MFG. CO.  
LORIS S.C.**

MATERIAL R.M.N.

APPLICATION L-65	OLD PART # ----
DESCRIPTION FRAME AND TANK COMPLETE FOR L-65 SPRAYER	

All Dimensions in Inches Unless Otherwise Specified  
Dimensions in [ ] are in Millimeters

Tolerances Unless Otherwise Specified  
Fractional Dimensions  $\pm 1/16"$  Angular Dimensions  $\pm 1^\circ$   
Decimal Dim. to Limits Shown All holes to  $b_{+0}^{+0.01/32}$

MANUFACTURED BY  
HARDEE MFG. CO., LLC

DO NOT SCALE	A DWG SIZE	DWG. NO. SHEET 3 OF 3	30096
--------------	---------------	--------------------------	-------