

ITEM NO.	PART NUMBER	QTY REQD.	NOMENCLATURE OR DESCRIPTION
1	10002	2	HEX BOLT (1/4" X 1")
2	10016	4	HEX BOLT (5/16" X 3/4')
3	10091	4	HEX BOLT (5/8" X 1-1/2")
4	10097	3	HEX BOLT (5/8" X 4-1/2")
5	10102	1	HEX BOLT (5/8" X 7")
6	10112	6	HEX BOLT (3/4" X 2-1/2")
7	10117	1	HEX BOLT (3/4" X 5")
8	10118	1	HEX BOLT (3/4" X 5-1/2")
9	10154	1	LOCK NUT (5/16")
10	10164	6	HEX NUT (1/2")
11	10165	5	HEX NUT (5/8")
12	10167	6	HEX NUT (3/4")
13	10168	6	LOCK NUT (3/4" REV.)
14	10181	5	LOCK WASHER (5/16")
15	10185	5	LOCK WASHER (5/8")
16	10186	11	LOCK WASHER (3/4")
17	10200	2	FLAT WASHER (1/4")
18	10201	4	FLAT WASHER (5/16")
19	10247	1	COTTER PIN (3/16" X 2-1/2")
20	10260	6	PLOW BOLT (1/2" X 1-1/2")
21	10307	1	CAT 1 PIN
22	10173	1	CASTLE NUT
23	10327	1	90 HP OMNI GEARBOX
24	10330	1	TIRE 4" X 8" X 15"
25	10335	0.5	PAINT (GAL.)
26	10336	1	GEAR OIL (GAL.)
27	10339	2	RIVET (1/8" X 3/8")
28	10475	1	SHAFT CONE
29	11001	1	DANGER DECAL
30	11002	2	KEEP CLEAR DECAL
31	11003	1	CAUTION DECAL
32	11004	1	CAUTION DECAL
33	11005	1	WARNING DECAL

DWG. NO.			REV.	
21406			J	
REV	CHANGE	BY	DATE	ECN
IR	INITIAL RELEASE	A.J.	11/6/96	----
J	DELETE PART 20005, 20207 - ADD 20497	R.T.N.	4/28/05	1065

34	11006	1	SAFETY DECAL
35	11012	2	MODEL NUMBER DECAL
36	11131	2	HARDEE LOGO DECAL
37	11567	1	DRIVESHAFT
38	11727	1	SERIAL PLATE
39	11850	1	WEBSITE DECAL
40	15852	2	RED REFLECTOR
41	15854	1	MANUAL HOLDER
42	15860	2	U-NUT 1/4"-20
43	20031	1	ACCESS COVER
44	20059	1	A-FRAME SPACER
45	20195	1	TAILWHEEL HUB COMPLETE
46	20201	1	A-FRAME BRACE WELDMENT
47	20202	1	LEFT A-FRAME BRACE WELD.
48	20242	2	TAILWHEEL ADJUSTERS
49	20244	2	A-FRAME BRACE
50	20247	2	SLIDE
51	20300	1	BLADE HOLDER W/BLADES
52	20491	2	FLAT STRUT
53	20497	1	TAILWHEEL FORK & ARM ASSEM.
54	20818	1	REAR RUBBER SHIELDING
55	20819	1	REAR BELTING FLAT
56	20861	1	FRONT RUBBER SHIELDING
57	20166	1	FRONT BELTING FLAT
58	21525	1	DECK WELDMENT, 1072L
59	10029	10	HEX BOLT (3/8" X 1-1/4")
60	10175	10	LOCK NUT (3/8")
61	10202	20	FLAT WAHSER (3/8")
62	20035	1	FLOATING LINKAGE WELDMENT

All Dimensions in Inches Unless Otherwise Specified
Dimensions in [] are in Millimeters

Tolerances Unless Otherwise Specified
Fractional Dimensions $\pm 1/16"$ Angular Dimensions $\pm 1'$
Decimal Dim. to Limits Shown All holes to be $^{+0}_{-1/32}$

DRAWN BY	M.J.T.	4/8/99	EVH MANUFACTURING CO LORIS S.C.	
CHECKED BY				
MATERIAL		R.M.N.	APPLICATION 1072R	OLD PART # ----
MANUFACTURED BY: EVH MANUFACTURING CO			DESCRIPTION ASSEMBLY DRAWING FOR 1072R	
DO NOT SCALE	A	DWG. NO.	21406	
	DWG SIZE	SHT 1 OF 2		

DWG. NO.

21406

REV.

J

REV	CHANGE	BY	DATE	ECN
G	CHANGE SERIAL # PLATE	T.R.M.	6/2/00	0792
H	CHANGE TO FLAT STRUT	T.R.M.	1/22/03	0937
I	DELETE PART 20005, 20207 - ADD 20497	R.T.N.	4/28/05	1065

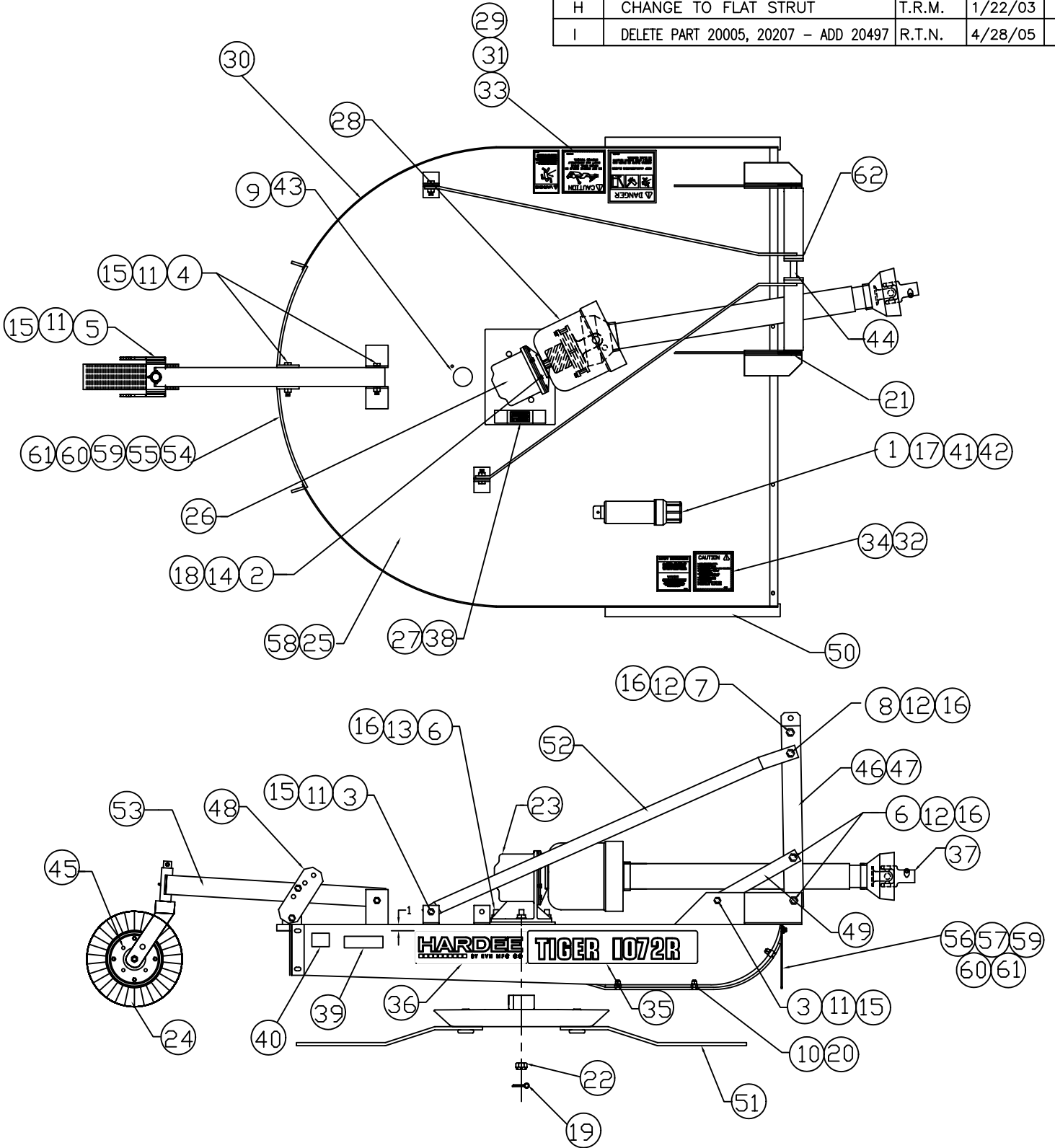

DRAWN BY M.J.T.	4/8/99	EVH MANUFACTURING CO LORIS S.C.	
CHECKED BY	R.M.N.		
MATERIAL		APPLICATION 1072R	OLD PART # ----
MANUFACTURED BY: EVH MANUFACTURING CO		DESCRIPTION ASSEMBLY DRAWING FOR 1072R	
DO NOT SCALE	A DWG SIZE	DWG. NO. SHT 2 OF 2	21406

All Dimensions in Inches Unless Otherwise Specified
 Dimensions in [] are in Millimeters

Tolerances Unless Otherwise Specified
 Fractional Dimensions $\pm 1/16"$ Angular Dimensions $\pm 1^\circ$
 Decimal Dim. to Limits Shown All holes to be $^{+0}_{-1/32}$

DWG. NO.

21406

REV.

I

REV	CHANGE	BY	DATE	ECN
E	ACCESS COVER REPLACEMENT	T.O.B.	11/5/99	0697
F	CHANGE PART NUMBER	T.R.M.	12/6/99	0688
G	CHANGE SERIAL # PLATE	T.R.M.	6/2/00	0792
H	CHANGE TO FLAT STRUT	T.R.M.	1/22/03	0937
I	DELETE PART 20005, 20207 - ADD 20497	R.T.N.	4/28/05	1065

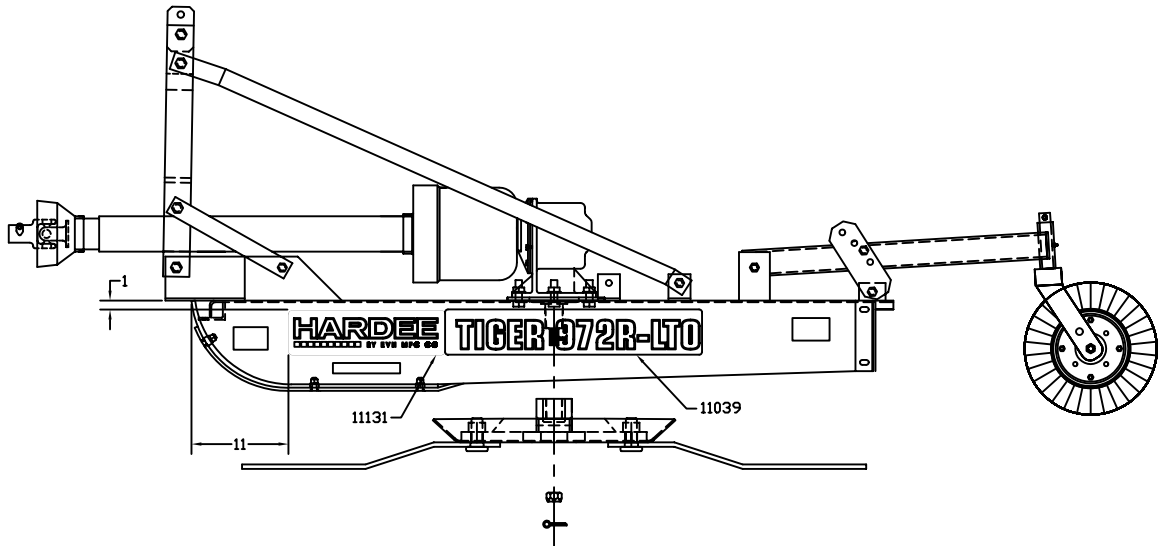

DRAWN BY	M.J.T.	4/8/99	EVH MANUFACTURING CO LORIS S.C.	
CHECKED BY				
MATERIAL		R.M.N.	APPLICATION	OLD PART #
MANUFACTURED BY:		EVH MANUFACTURING CO	1072R	----
			DESCRIPTION	
			ASSEMBLY DRAWING FOR 1072R	
DO NOT SCALE	A	DWG. NO.	21406	
		DWG SIZE	SHT 2 OF 2	

All Dimensions in Inches Unless Otherwise Specified
 Dimensions in [] are in Millimeters

Tolerances Unless Otherwise Specified
 Fractional Dimensions $\pm 1/16"$ Angular Dimensions $\pm 1^\circ$
 Decimal Dim. to Limits Shown All holes to be $^{+0}_{-1/32}$

ITEM NO.	PART NUMBER	QTY REQD.	NOMENCLATURE OR DESCRIPTION
1	20236	1	BLADE HOLDER WELDMENT
2	10313	2	BLADE BOLT GR.8
3	10421	2	UP LIFT BLADE
4	10311	2	BLADE BOLT NUT GR.8
5	10312	2	BLADE BOLT LOCKWASHER GR.8

DWG. NO.			REV.	
20300			IR	
REV	CHANGE	BY	DATE	ECN
IR	INITIAL RELEASE	M.J.T	11/30/98	----

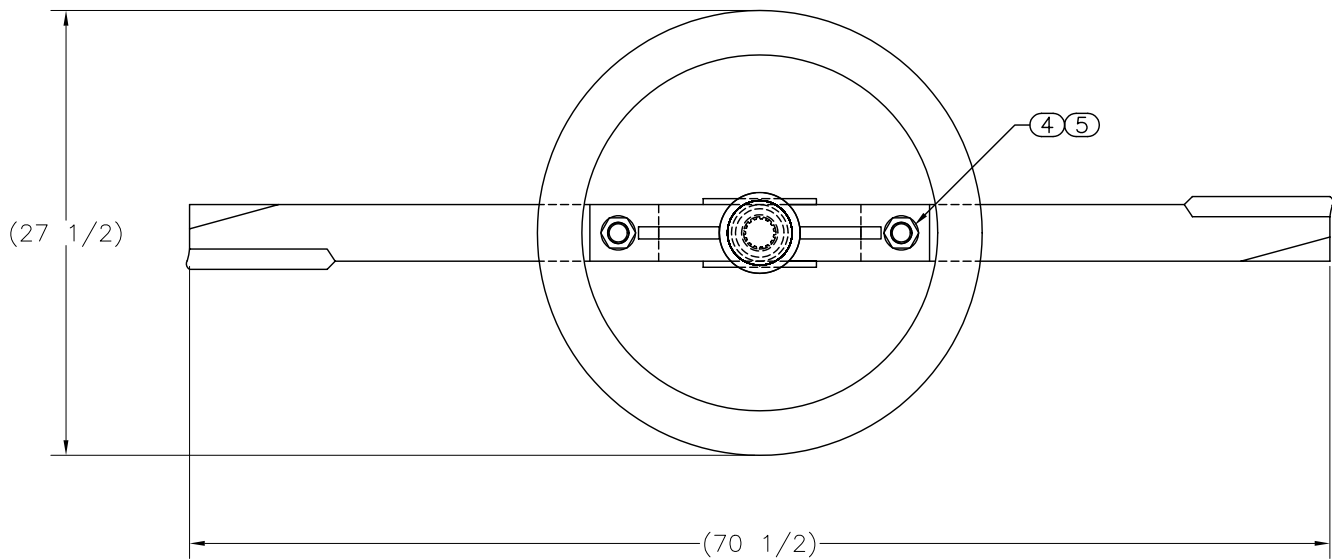
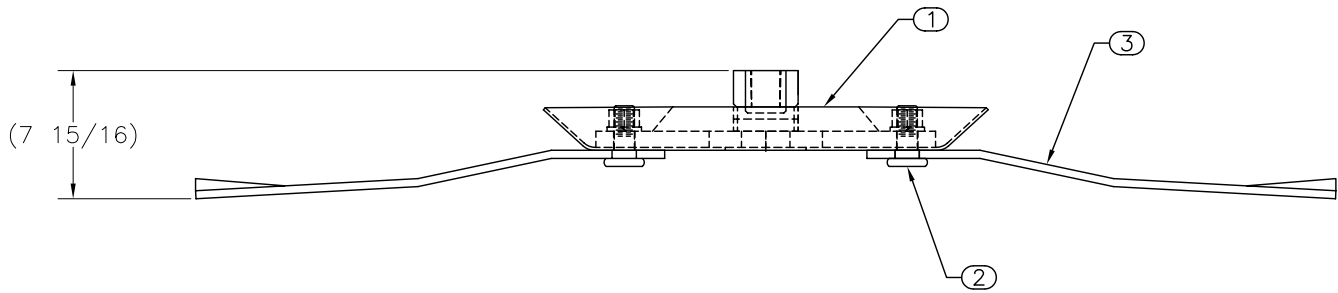

DRAWN BY	M.J.T	6/10/98
CHECKED BY		
MATERIAL	R.M.N.	

**HARDEE
BY EVH MFG
LORIS S.C.**

APPLICATION	OLD PART #
DESCRIPTION BLADE HOLDER SUBASSEMBLY	

All Dimensions in Inches Unless Otherwise Specified
Dimensions in [] are in Millimeters

Tolerances Unless Otherwise Specified
Fractional Dimensions $\pm 1/16"$ Angular Dimensions $\pm 1^\circ$
Decimal Dim. to Limits Shown All holes to be $\begin{matrix} +0 \\ -1/32 \end{matrix}$

DO NOT SCALE	A DWG SIZE	DWG. NO. 20300
--------------	---------------	-------------------

10327 Gearbox

(90H.P. Gearbox 1: 1.47 Ratio)

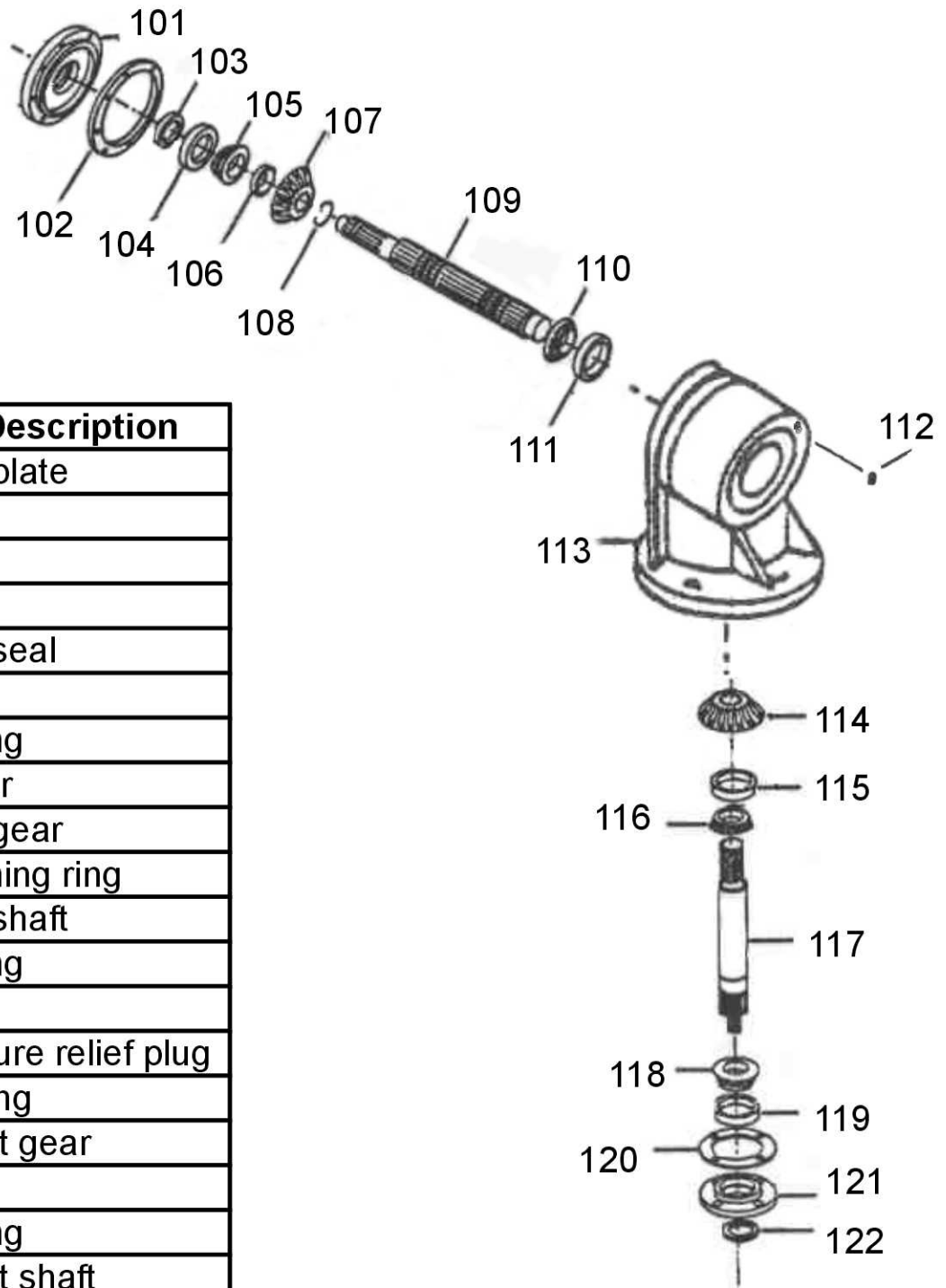

Key #	Part No.	Part Description
101	15768	Face plate
102	15732	Shim
	15733	Shim
	15734	Shim
103	15715	Input seal
104	11240	Cup
105	11241	Bearing
106	15606	Spacer
107	10683	Input gear
108	10353	Retaining ring
109	15602	Input shaft
110	11241	Bearing
111	11240	Cup
112	15664	Pressure relief plug
113	11516	Housing
114	10682	Output gear
115	11243	Cup
116	10352	Bearing
117	15600	Output shaft
118	10352	Bearing
119	11242	Cup
120	15706	Shim
121	15705	Bottom cover
122	10354	Output seal

11567 Driveshaft

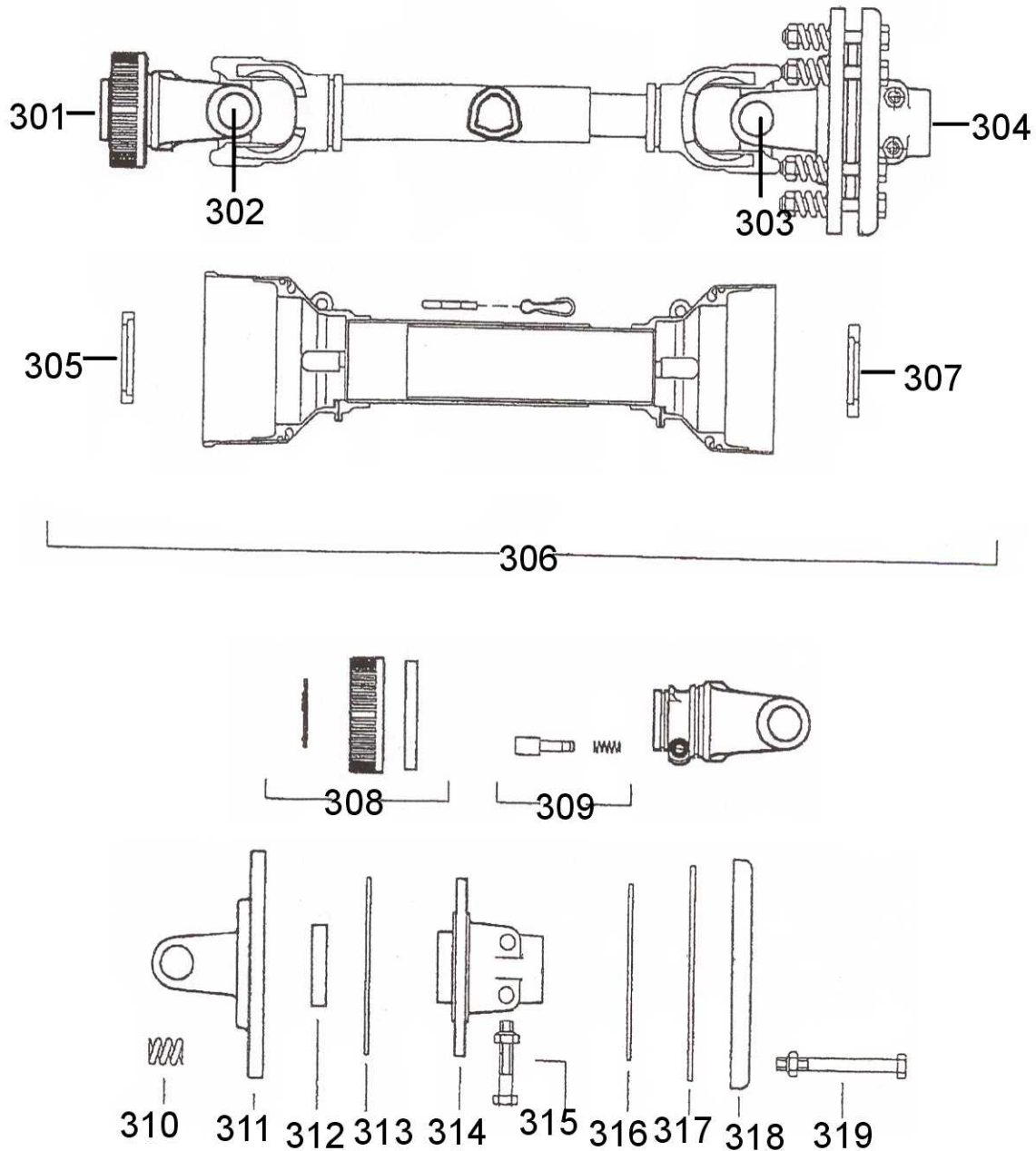

Key #	Part No.	Description	Key #	Part No.	Description
301	11440	Yoke, Tractor end	311	15806	Flange yoke
302	15559	Cross kit	312	15562	Bushing
303	15559	Cross kit	313	11204	Clutch facing
304	11444	Clutch, complete	314	15802	Center hub
305	15800	Shield bearing	315	15803	Clutch bolt
306	11749	Shield kit complete	316	11204	Clutch facing
307	15801	Shield bearing	317	15563	Inner plate
308	15786	Twist collar kit	318	15799	Pressure plate
309	15579	Push pin complete	319	15794	Clutch bolt
310	15561	Spring			