

ITEM NO.	PART NUMBER	QTY REQD.	NOMENCLATURE OR DESCRIPTION
1	10098	5	HEX BOLT (5/8" X 5")
2	10099	1	HEX BOLT (5/8" X 5-1/2")
3	10166	26	LOCK NUT (5/8)
4	10172	4	HEX HEAD LOCKNUT (1-1/8)
5	10339	2	RIVET, (1/8" X 3/8")
6	10469	2	HITCH PIN W/CLIP, CAT 1, 7/8" X 4-1/4"
7	10901	2	BUMPER CAP (FRONT)
8	10906	8	BEARING SPACER
9	10907	4	NUT WASHER
10	10913	18	18" DISC BLADE 1-1/8" HOLE
11	10916	2	GANG BOLT 30-3/4"
12	10918	4	HALF SPOOL 6"
13	10919	4	SPOOL 9"
14	11032	3	HARDEE LOGO DECAL
15	11055	2	DECAL FOR D-18-1618
16	11636	1	LANDSCAPE & DISC HARROW SAFETY DECAL
17	11727	1	HARDEE SERIAL NUMBER PLATE
18	11850	1	WEB SITE DECAL
19	15450	16	CARRIAGE BOLT (5/8" X 5")
20	15465	4	TUBING INSERT, 3" 5-8 GAGE
21	15852	2	DECAL RED REFLECTOR
22	60023	8	CLAMP CAP FOR D-18, D-20
23	60024	4	PLATE WELDMENT
24	60029	1	GANG PIN REAR, WELD.
25	60037	4	LOCK NUT
26	60038	1	GANG PIN FRONT, WELDMENT
27	60050	2	BEAM, GANG (35")
28	60065	1	MAIN FRAME WELDMENT D-18
29	60080	2	BEAM, GANG (40")
30	60081	2	BUMPER CAP, SLOTTED (REAR)
31	60126	1	A-FRAME WELD.(D-18 & D-20)
32	60133	1	A- FRAME BRACE WELD.
33	60275	4	LEFT AXLE HANGER ASSEMBLY
34	60276	4	RIGHT AXLE HANGER ASSEMBLY
35	15853	2	DECAL YELLOW REFLECTOR

DWG. NO.			REV.	
60085			G	
REV	CHANGE	BY	DATE	ECN
A	ADD LOGO AND MODEL DECALS	M.J.T.	5/21/99	0613
B	MRP B.O.M. CHANGES	T.O.B.	12/13/99	0698
C	MRP B.O.M. CHANGES	T.R.M.	6/12/00	0792
D	MRP B.O.M. CHANGES	R.T.N.	3/25/03	0949
E	MRP B.O.M. CHANGES	T.R.M.	3/23/04	0958
F	REASSEMBLED 60085	J.S.S.	3/17/09	1289
G	REASSEMBLED 60085	J.S.S.	5/1/09	1302

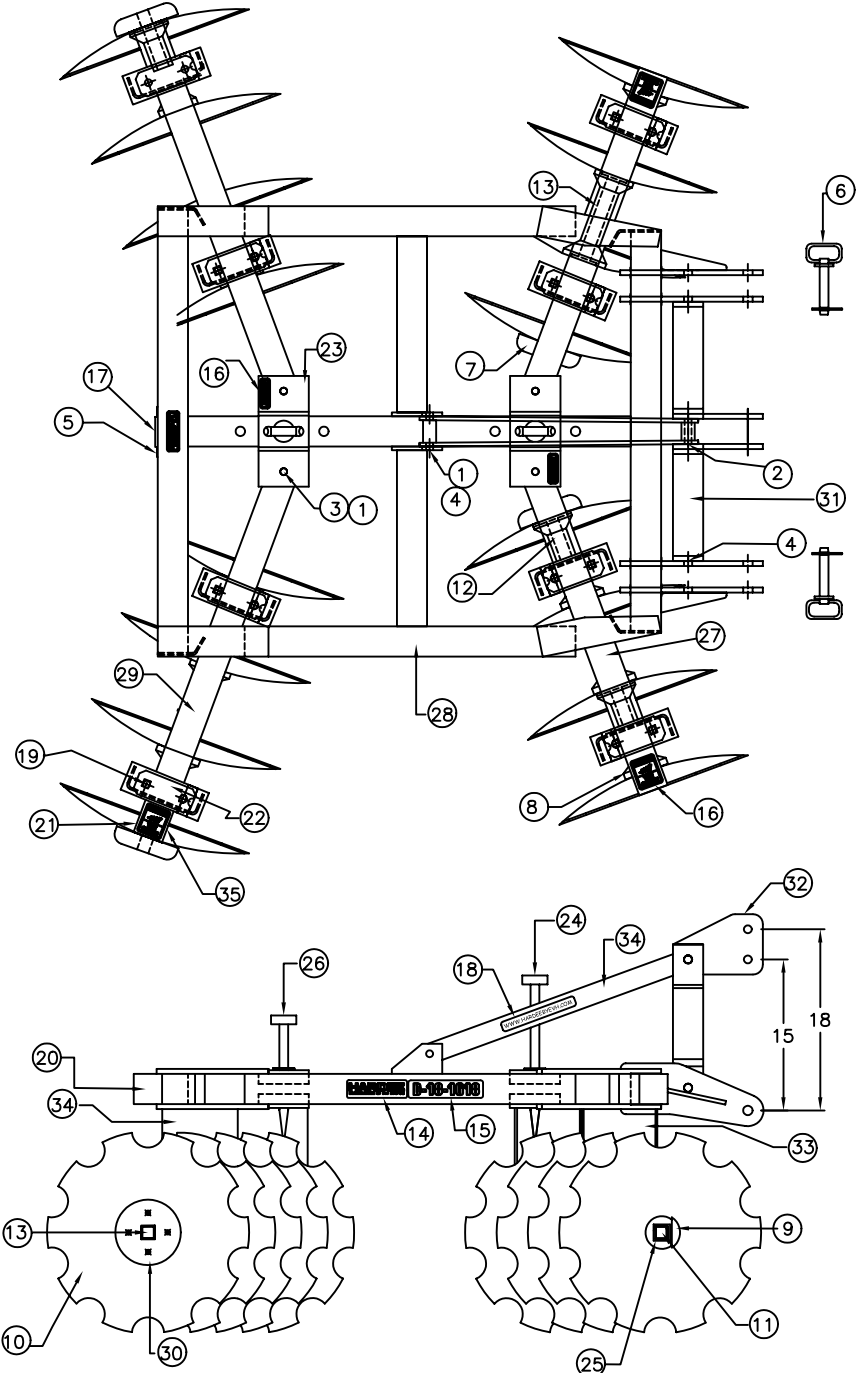

All Dimensions in Inches Unless Otherwise Specified
 Dimensions in [] are in Millimeters

Tolerances Unless Otherwise Specified
 Fractional Dimensions ±1/16" Angular Dimensions ±1°
 Decimal Dim. to Limits Shown All holes to be +0/-1/32

DRAWN BY	J.S.S.	5/1/09
CHECKED BY		
MATERIAL	R.M.N.	---
MANUFACTURED BY:	EVH MFG. CO., LLC	

**HARDEE BY EVH
MFG. CO., LLC
LORIS S.C.**

APPLICATION	OLD PART #
DISC HARROW	----
DESCRIPTION D-18-1618 ASSEMBLY	
DO NOT SCALE	DWG. NO.
A	SHT 1 OF 1
60085	