



OPERATOR'S AND MAINTENANCE MANUAL

Heavy-Duty Pull Type Scraper



DANGER

Read this manual and the manual for your tractor carefully to acquaint yourself before operating!

PTS-96

4895 RED BLUFF RD, LORIS, SC-29569

(843) 756-2555

evhmfg@hardeebyevh.com

www.hardeebyevh.com

MODEL NUMBER _____
SERIAL NUMBER _____
DATE OF PURCHASE _____

Customer Pre-Operation Check List		Reference
<input type="checkbox"/>	Read, understand and follow the general safety rules listed in this manual.	Page 2
<input type="checkbox"/>	Take note of all warning and safety decals.	Page 3-4

Table of Contents

Section 1 Introduction	1
To Our Customers	1
Owner's	1
Purpose Of This Manual	1
Safety-Alert Symbol	1
Signal Words	1
Customer Assistance	1
Section 2	2
General Safety	2
Safety Decals	3
Safety Decals Locations	4
Section 3 Operation	5
Attaching to Tractor	5
Transporting	5
Un-Attaching From Tractor	5
Scraping Instructions	6
Operating Environment	6
Section 4 Maintenance	7
Maintenance Information	7
Tractor Maintenance	7
Cutting Blade	7
Storage	7
Section 5 Replacement Parts	8
PTS-96	8
Section 6 Reference	9
Bolt Torque	9
Checking Bolt Torque	9
Torque Specifications Coarse Thread	9
Torque Specifications Fine Thread & Head Markings	10
Section 7 Warranty	11
Notes	12

To Our Customers

We at Hardee by EVH Manufacturing Company thank you for buying your new Heavy-Duty Pull Type Scraper.

We have tried hard to build a heavy-duty pull type scraper to do the work you have in mind. Many hours of engineering, field-testing and improvement have gone into the design and fabrication of your heavy-duty pull type scraper. We will strive to continue this quality of manufacturing in the future, always keeping the customer's needs clearly in mind.

The best performance of your heavy-duty pull type scraper will depend on you. Proper maintenance, hookup, adjustments and operation are essential for it to give you long and dependable service. However, as with any type of equipment, your heavy-duty pull type scraper is designed to perform specific functions.

In this manual, you will find instructions on heavy-duty pull type scraper features, maintenance and operation. If customer service or repair parts are required, contact your local Hardee dealer. Please specify model and serial number when ordering parts.

Owner's Responsibility

The manufacturer has no control over the ultimate use of the heavy-duty pull type scraper and therefore assumes no responsibility or liability for damage or injury resulting from the use of this equipment.

The upkeep of the heavy-duty pull type scraper is the responsibility of the user. This upkeep includes all shielding, guards, and safety decals (OSHA Regulation 1928.57). You can obtain replacement parts from any authorized Hardee dealer.

Read this Operator's Manual before using the heavy-duty pull type scraper. Failure to do so could result in injury to the operator or to others. Remember that most accidents occur due to neglect or carelessness. The operator is responsible for inspecting and making repairs as may be necessary. Cleaning after each use and storage under a shelter will extend the life of the heavy-duty pull type scraper.

Purpose of This Manual

This manual provides information on safety, operation, adjustments, troubleshooting and maintenance of your new heavy-duty pull type scraper. Please read and follow all the recommendations to help ensure that

you get many years of service from your new Hardee heavy-duty pull type scraper.

If you need additional copies of this manual, please contact your local Hardee dealer or download a copy from our website at www.hardeebyevh.com.

Safety-Alert Symbol



This symbol is the safety alert symbol. It appears throughout this manual to call your attention to instructions involving your personal safety and the safety of others. Failure to follow these instructions can result in injury or death.

Signal Words

Safety signal words are words that call attention to the safety sign and designate a degree or level of hazard seriousness. The signal words used throughout this manual are DANGER, WARNING and CAUTION. Please read and follow all safety messages that have these signal words shown for your protection.



DANGER

Indicates an imminently hazardous situation which, if not avoided, will result in death or serious injury.



WARNING

Indicates a potentially hazardous situation which, if not avoided, could result in death or serious injury.



CAUTION

Indicates a potentially hazardous situation which, if not avoided, may result in minor or moderate injury

Customer Assistance

The Hardee sales team would like you to be satisfied with your new Heavy-Duty Pull Type Scraper. If for some reason you have any questions about the information in this manual or have a problem with your heavy-duty pull type scraper, please discuss the problem or question with the management of your local dealership. If further assistance is required, please contact:

Hardee By EVH Manufacturing Company, LLC
Sales Department
4895 Red Bluff Road, Loris, SC 29569
843-756-2555

Safety Information

General Safety Rules

This section of your manual will address the safe operation of your new heavy-duty pull type scraper. We at Hardee strive to produce equipment that is both a quality product and safe to operate. Please take the time to read, understand and follow the safety rules listed below and throughout this manual.

Your safety also depends on you becoming familiar with the basic operation of your new heavy-duty pull type scraper. You can find complete instructions for this heavy-duty pull type scraper in the Operation Instruction section of this manual. We believe that using your heavy-duty pull type scraper safely; in a safe environment will give you great results!

DANGER

This equipment is designed to be used with a Roll Over Protective Structure (ROPS) equipped tractor of not more than 100 HP. The PTS Heavy-Duty Pull Type Scraper is designed to grade or move large quantities of material, leveling, and finish grading. No other use is intended.

There are obvious and hidden potential hazards in operating heavy-duty pull type scrapers, as in all power-driven equipment. REMEMBER! This machine is often operated in rough terrain conditions that include gullies, holes, slopes, hidden obstructions and the like. Serious injury or even death may occur unless care is taken to assure the safety of the operator and bystanders in the area.

Included here is a list of safety messages which should be followed. Observing these messages and using common sense learned from experience will go far toward eliminating the hazards of operating this and other such machinery.

DANGER

Read this manual and the manual for the tractor carefully to acquaint yourself with both machines before operating. REMEMBER! Power-driven equipment should be operated only by those trained and familiar with the operation and instructed to do so. Working with unfamiliar equipment or in unfamiliar conditions can lead to accidents.

WARNING

Do not modify or alter this machine or any of its components or any equipment function without consulting Hardee By EVH Mfg. Customer Service.

WARNING

Failure to keep the tractor level may result in loss of traction, tipping, rollover, property damage, personal injury or death.

WARNING

The operator and all support personnel should wear hard hats, safety glasses, and safety shoes for personnel protection.

WARNING

Before leaving the tractor seat, always engage the tractor brake and/or set the tractors transmission in parking gear. Set the heavy-duty pull type scraper on the ground or securely block up. Stop engine and remove key.

DANGER

Falling while mounting or dismounting a moving tractor can cause crushing injury or death.

WARNING

Operate tractor controls from the seat only. Inadvertent dropping or movement of components may cause serious injury or death.







DANGER

Never allow children to play or ride on tractor or equipment. Children may also distract the operator and cause an accident due to inattention.

DANGER

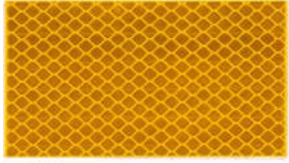
On heavy-duty pull type scrapers that will fall down if not supported, always set on a hard flat surface, with stand installed properly to prevent falling and possible crushing and or back injury from heavy lifting.

SAFETY DECALS

		
<p>11131-ITEM 1 (4)</p>	<p>15852-ITEM 2 (2)</p>	<p>15853-ITEM 3 (2)</p>
		
<p>11636-ITEM 4 (3)</p>	<p>11636-ITEM 5 (2)</p>	<p>11636-ITEM 6 (1)</p>
<p>ITEM</p>	<p>PART NUMBER / (QTY)</p>	<p>DESCRIPTION</p>
<p>1</p>	<p>11131 (4)</p>	<p>Large Hardee Decal</p>
<p>2</p>	<p>15852 (2)</p>	<p>Red Reflector Decal</p>
<p>3</p>	<p>15853 (2)</p>	<p>Yellow Reflector Decal</p>
<p>4</p>	<p>11636-ITEM 4 (3)</p>	<p>Pinch Point Decal</p>
<p>5</p>	<p>11636-ITEM 5 (2)</p>	<p>Toe Crush Decal</p>
<p>6</p>	<p>11636-ITEM 6 (1)</p>	<p>Crushing Hazard Decal</p>

Safety Information

Safety Decals Locations

Your Hardee heavy-duty pull type scraper ships with all safety decals in place. They are located in areas on the scraper that are potentially hazardous. Please locate, read and follow the information you find on these decals.

By law, you must replace any safety decals that are damaged or missing. You can order replacement decals from any local Hardee dealer. Just ask for part number 11636.

To apply the replacement decals:

- Clean the surface to place the new decal.
- Peel the decal away from the paper backing.
- Press firmly onto the clean surface.
- Squeeze out any air pockets using a straight edge.

DECAL CHART

Note: Part Number 11636 can not be ordered as individual items.

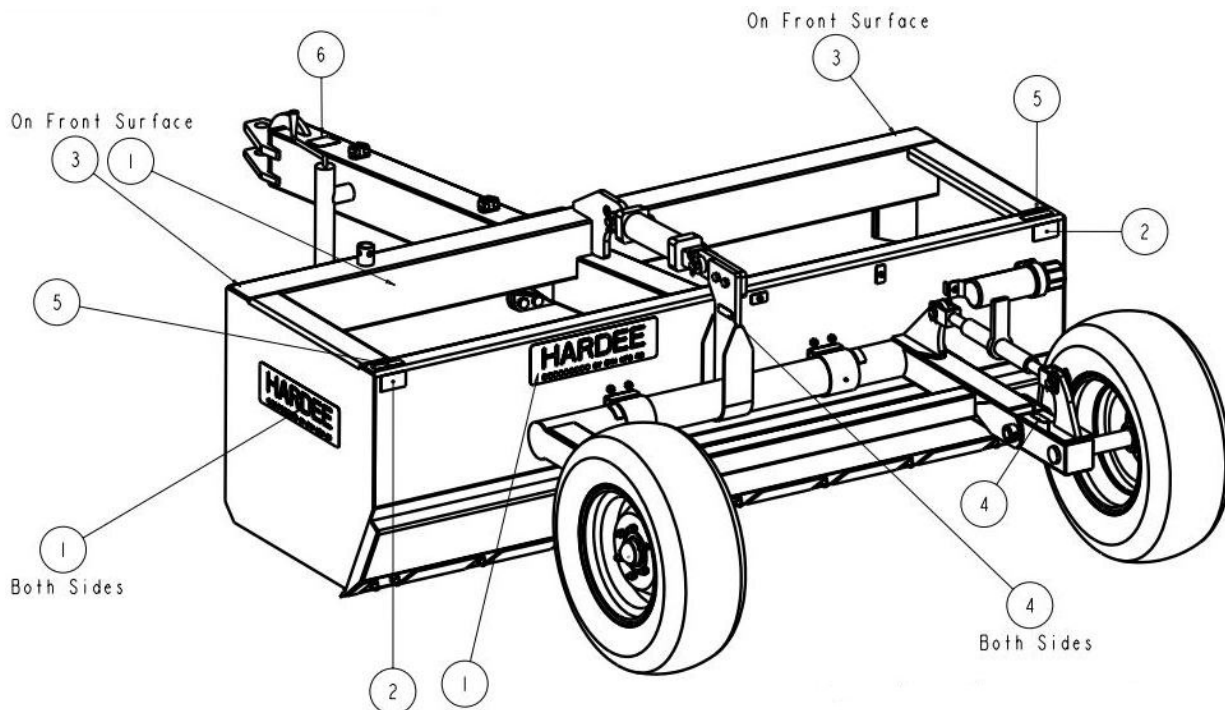

Operation Instructions

During Operation

Your PTS Heavy-Duty Pull Type Scraper should be inspected for any evidence of defective or damaged parts before use. Any evidence of damage should be reported to your dealer immediately. All joints requiring grease should be inspected and greased if necessary.

DANGER

Potential for crushing hazard between tractor and heavy-duty pull type scraper may occur. Do not allow anyone to stand between the tractor and heavy-duty pull type scraper while backing-up. Do not operate hydraulic controls while someone is directly behind the tractor or near the heavy-duty pull type scraper.

ATTACHING TO TRACTOR

- Back tractor within close proximity of clevis.
- Shut off tractor and operate control arms back and forth to release all hydraulic line pressure.
- Attach heavy-duty pull type scraper hoses to the tractor hydraulic system.
- Return to tractor, start tractor, and operate control lever to raise rear wheels up until heavy-duty pull type scraper hitch aligns with tractor drawbar.
- Back tractor up to the hitch until hitch holes align with drawbar hitch hole.
- Engage parking brake, shut off tractor and remove key before dismounting from tractor to hook-up heavy-duty pull type scraper.
- Attach heavy-duty pull type scraper hitch to tractor with customer supplied hitch pin and safety chain to tractor. Make sure hitch pin is secured with a hitch pin keeper and safety chain is secured to the tractor hitch frame.

TRANSPORTING

CAUTION

When traveling on public roads at night or during the day, use accessory lights and devices for adequate warning to operators of other vehicles. Comply with all federal, state and local laws.

- Select a safe ground travel speed when transporting from one area to another.
- Be sure to reduce tractor ground speed when turning; and leave enough clearance so the

heavy-duty pull type scraper does not contact obstacles such as buildings, trees, or fences.

- Shift to a lower gear when traveling over rough or hilly terrain.
- When traveling on roadways, transport in such a way that faster moving vehicles may pass you safely.

UN-ATTACHING FROM TRACTOR

CAUTION

Always engage parking brake, shut off tractor, and remove key before dismounting from tractor to unhook equipment.

- Park heavy-duty pull type scraper on a level solid hard surface.
- If optional tilt axle cylinder is included, fully retract cylinder to level the heavy-duty pull type scraper's cutting edge.
- Retract lift cylinder to lower heavy-duty pull type scraper unit until cutting edge is resting on the ground and hitch weight is off the tractor drawbar.
- Shut tractor off before removing hitch pin and safety chain.
- Move tractor forward until tractor drawbar is clear of heavy-duty pull type scraper hitch. Do not travel so far forward as to cause the hydraulic quick release couplings to disconnect.
- Use lift control lever to lower scraper until scraper blade and side plates are resting on the ground.
- Shut tractor engine off. Operate control arms back and forth to release all hydraulic line pressure.
- Unhook hydraulic hoses from tractor. Store hose ends in hose support loop. Store hitch pin with heavy-duty pull type scraper. If hitch pin is used with other equipment, store hitch pin with the tractor.
- Drive tractor carefully away from heavy-duty pull type scraper.

Scraping Instructions

Once you have familiarized yourself with the Operator's Manual, completed the operations checklist, and properly attached your heavy-duty pull type scraper to your tractor, you are now ready to begin working. Make sure you have checked out your work site for any buried utility cables, pipelines, or other obstacles that you wouldn't want to damage or encounter.

Heavy-Duty Pull Type Scrapers are ideal for moving large quantities of material, leveling, finish grading, and removal of material on an angle. They have applications on feedlots, outdoor arenas, building sites, maintenance operations on farms, private roadways, sloping ground, building terraces, and making ditches.

Your heavy-duty pull type scraper's primary purpose is grading and leveling. If tilt axle is used, it can also do angle work. These functions are best done at an approximate ground speed of 2 to 4 mph. Simply lower the heavy-duty pull type scraper to the ground and proceed forward. The grader blade should immediately begin shaving the soil surface or aggregate material and accumulating it in the box. You can transfer this material by dragging it to a nearby location and then raising the heavy-duty pull type scraper to deposit your load. You can also achieve uniform distribution and leveling of scraped material by setting the heavy-duty pull type scraper to shave off high spots and allowing accumulated material to flow out under the grader blade in low spots. Achieving the desired effect will require a little experimentation and experience. Heavy-Duty Pull Type Scrapers generally perform better in dry to slightly damp soil conditions.

Your Heavy-Duty Pull Type Scraper can also be used for making slopes, terracing, and ditching if the tilt axle is used. Just simply extend the tilt cylinder to lower the right side of the grader blade. Fully retract the tilt cylinder to return the grader blade to level.

With a little practice you should become a very good operator and consistently achieve the desired results you expect with your Heavy-Duty Pull Type Scraper.

Operating Environment

Application Do's and Don'ts

There are obvious and hidden potential hazards in operating this equipment. **REMEMBER!** This equipment is often operated in rough terrain conditions that include gullies, holes, slopes and hidden obstructions. Serious injury or even death may occur unless care is taken to assure the safety of the operator and bystanders in the area.

Maintenance

Maintenance Information

Proper servicing and adjustment is the key to the long life of any implement. With careful inspection and routine maintenance, you can avoid costly downtime and repair.

Check all bolts after using the unit for several hours to be sure they are tight. Replace any worn, damaged, or illegible safety labels by obtaining new labels from your Hardee By EVH Manufacturing Co. dealer.

The parts on your Heavy-Duty Pull Type Scraper have been specially designed and should only be replaced with Hardee By EVH Manufacturing Co. parts. Do not alter the heavy-duty pull type scraper in a way which will adversely affect its performance.

CAUTION

Do not alter Hardee By EVH Manufacturing Co. equipment or replace parts with other brands. Doing so can cause equipment to perform improperly and may lead to breakage that can cause bodily injury. Replace parts only with genuine Hardee By EVH Manufacturing Co. parts.

Tractor Maintenance

One of the most important things you can do to prevent hydraulic system problems is ensure that your tractor's reservoir remains free of dirt and contamination. Use a clean cloth to wipe hose ends before attaching them to your tractor. Replace your tractor's hydraulic filter element at the prescribed intervals. These simple maintenances will go a long way to prevent occurrence of hydraulic cylinder problems.

Cutting Blade

DANGER

Always secure scraper in the up position with solid supports before servicing the underside. Never work under equipment supported by hydraulics. Hydraulics can drop equipment if controls are actuated or if hydraulic lines burst. Either situation can drop the heavy-duty pull type scraper instantly even when power to the hydraulics is shut off.

Always inspect cutting blade before each use. Make certain it is properly installed and in good working

condition.

- Unbolt cutting blade and turn it over when the bottom cutting edge is worn out. Replace blade when the top and bottom edges are worn out.
- Inspect 5/8" 11 x 2" GR5 plow bolts and hex flange lock nuts for wear. Replace if worn out.
- Re-attach blade with plow bolts and hex flange lock nuts. Tighten nuts to the correct torque.

Storage

Clean, inspect, service, and make necessary repairs to the heavy-duty pull type scraper when parking it for long periods and when parking it at the end of a working season. This will help ensure that the heavy-duty pull type scraper is ready for field use the next time you hook-up to it.

DANGER

Always secure your heavy-duty pull type scraper in the up position with solid supports before working under the heavy-duty pull type scraper.

- Scrape off compacted dirt and then wash the heavy-duty pull type scraper surfaces thoroughly with a garden hose.
- Check grader blade and grader blade mounting bolts for wear. Reverse or replace grader blade if needed. Replace hardware if worn excessively.
- Inspect scraper for loose, damaged, or worn parts. Adjust and tighten loose parts or replace as needed.
- Repaint parts where paint is worn or scratched to prevent rust.
- Replace all damaged or missing decals.
- Apply a light coat of oil or grease to the lower moldboard, side panels, grader blade, and exposed hydraulic cylinder rods to minimize oxidation.
- Store your heavy-duty pull type scraper on a level surface in a clean, dry place. Inside storage will reduce maintenance and make for a longer life.

Section 5 - Replacement Parts

DWG. NO.	40399	REV.	IR
REV. CHANGE	BY	DATE	ECN
IR INITIAL RELEASE	C.K.N	6/30/15	1624

Repair Parts Drawing

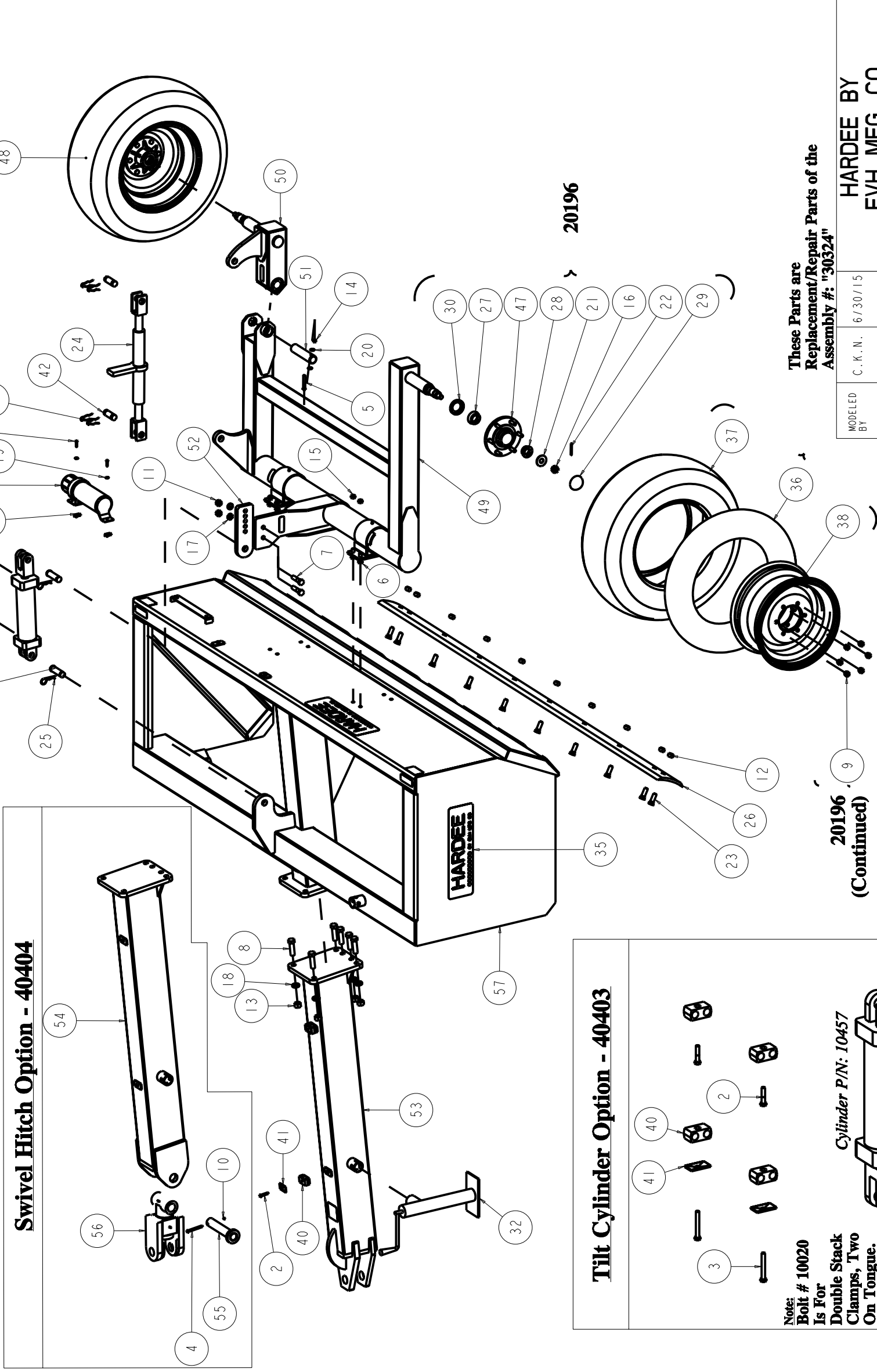

These Parts are Replacement/Repair Parts of the Assembly #: "30324"

MODELED BY	C.K.N.	6/30/15	R.M.N.	DESCRIPTION	SHEET 3 of 3
DRAWN BY	C.K.N	6/30/15			
Manufactured By: EVH Mfg. Co., LLC			PTS 96 Complete		
DO NOT SCALE			DWG. NO. 40399		

20196 (Continued)

All Dimensions in Inches Unless Otherwise Specified	
Dimensions in [] are in Millimeters	
Tolerance Unless Otherwise Specified	
Fractional Dimensions ± 1/16"	Angular Dimensions ± 1°
Decimal Dim. to Limits Shown	All Holes to be +0 -1/32"

Swivel Hitch Option - 40404

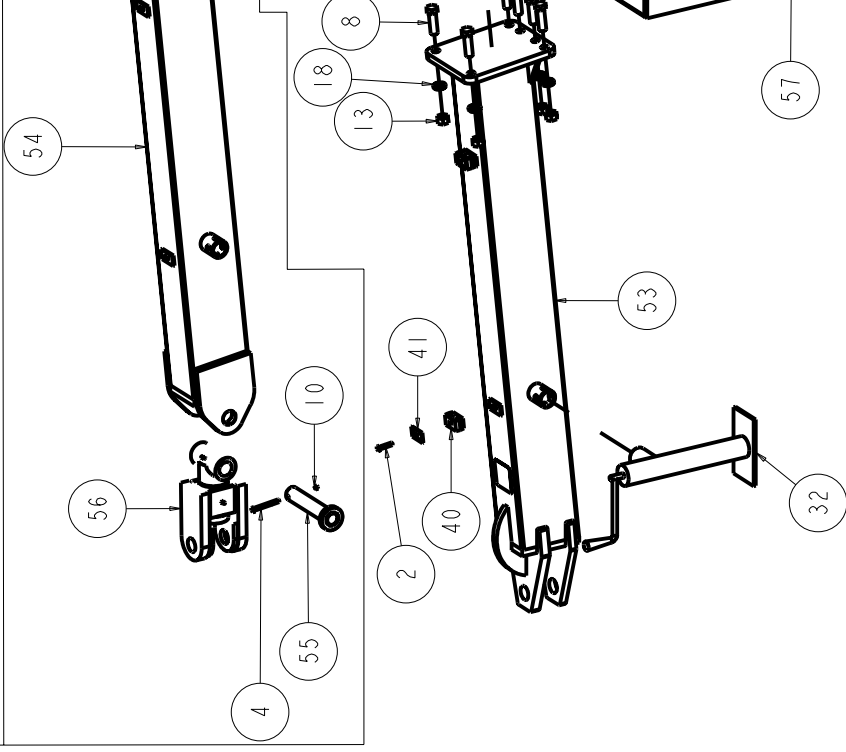

Tilt Cylinder Option - 40403

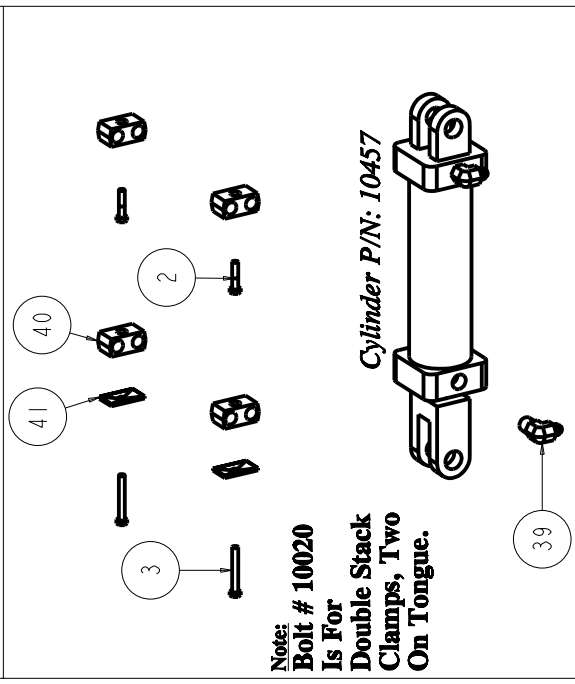

Item	Part Number	Qty.	Description
1	10002	2	Hex Bolt, 1/4"-20 X 1" Gr.5 Plated
2	10018	4	Hex Bolt 5/16" X 1 1/2" gr.5 Plated
3	10020	2	Hex Bolt 5/16" X 2 1/2" gr.5 Plated
4	10021	1	Hex Bolt 5/16" X 3" gr.5 Plated
5	10034	1	Hex Bolt 3/8" x 2-1/2" gr.5 plated
6	10072	8	Hex Bolt 1/2" x 1 1/2 gr.5 plated
7	10093	2	Hex Bolt 5/8" x 2-1/2" gr.5 plated
8	10112	6	Hex Bolt 3/4" X 2-1/2" gr.5 Plated
9	10150	12	Lug Nut (1/2" - 20 UNF)
10	10154	1	Lock Nut 5/16"-18 Plated
11	10165	2	Hex Nut 5/8" plated
12	10166	11	Lock Nut 5/8"-11 plated
13	10167	6	3/4" Hex Nut (Gr.5 Plated)
14	10175	1	3/8"-16 Locknut (Gr.5 Plated)
15	10176	8	1/2" Locknut (Gr.5 Plated)
16	10179	2	Castle Nut (3/4") Gr.5 Fine Thread
17	10185	2	Lockwasher 5/8" Plated
18	10186	6	Lockwasher 3/4" Plated
19	10200	2	1/4" Plated Flatwasher
20	10202	2	3/8" Flatwasher (Plated)
21	10206	2	Flatwasher 3/4 plated
22	10252	2	Cotter Pin 3/16" X 2" Plated
23	10264	10	Plow Bolt 5/8 x 2 Gr.5 Plated
24	10343	1	Ratchet Jack
25	10391	2	Clip Pin (Hairpin) 3/16 X 3-1/4"
26	10434	1	96 Cutting Edge
27	10437	2	Inner Bearing
28	10438	2	Outer Bearing
29	10439	2	Dust Cap
30	10440	2	Grease Seal
31	10457	2	Hydraulic Cylinder, 3" X 8"
32	10618	1	10" Jack
33	10924	2	3/8"X163"Hyd. Hose
34	10927	2	1" X 3" Cylinder Pin
35	11131	4	Large Hardee Logo Decal
36	11842	2	Tube for 9.5L x 15 Tire
37	11843	2	11L X 15 Tire
38	13277	2	Wheel, 15" x 8", 6 Lug
39	13905	4	6-M-JIC X 8-M-NPT 90 Deg. Elbow
40	15291	6	5/8" Tube Clamp Set - Twin, Polypropylene
41	15293	4	Cover Plate - Twin, Group 2
42	15447	2	1" X 2-13/16" Pin
43	15448	4	Clip for 15447 Ratchet Jack Pin
44	15471	2	3/8" X 228" Hyd. Hose W/ 6-F-JIC X 8-M-NPT
45	15854	1	Manual Holder
46	15860	2	U-Nut, 1/4"-20
47	25203	2	6 Lug Hub with Cups and Studs
48	30324	2	11L X 15 Tire, Tube and Rim
49	40432	1	Tailwheel Frame Weldment
50	40451	1	Tilt Arm Weldment
51	40456	1	Pin, Tilt Arm
52	40457	1	Cylinder Adjusting Bracket
53	40458	1	Tongue Weldment, Standard
54	40459	1	Tongue Weldment, Swivel
55	40468	1	Pin Weldment, Swivel Hitch
56	40472	1	Swivel Hitch Weldment
57	40484	1	Frame Weldment, PTS 96

Note:

2 - 10924 Hoses (Not Shown)

2 - 15471 Hoses (Not Shown)

Bolt Torque

Checking Bolt Torque

The tables shown below give correct torque values for various bolts and capscrews. Tighten all bolts to the torque specified in the chart unless otherwise noted. Check tightness of bolts periodically, using bolt torque chart as a guide. Replace hardware with the same strength bolt. Torque figures indicated are valid for non-greased or non-oiled threads and heads unless otherwise specified. Therefore, do not grease or oil bolts or cap screws unless otherwise specified in this manual. When using locking elements, increase torque values by 5%.

NOTE: Bolt Torques shown are maximum allowable values for ultimate safe working strength or external load-carrying capacity. The bolt torque are not applicable in cases where bolts are used as a pin-like device, holding together two or more movable objects and keeping them from spreading apart. – “Clamping Torque” Being dependent upon the application of the bolt. -

*Torque value for bolts and cap screws are identified by their head markings.
See Page 21.*

Torque Specifications for Coarse Threads

Diameter “A”	Bolt Torque		Coarse Thread			
	SAE-2		SAE-5		SAE-8	
	LB-FT	N.m	LB-FT	N.m	LB-FT	N.m
1/4" - 20	6	8	9	12	12	17
5/16" - 18	10	13	19	25	27	36
3/8" - 16	20	27	33	45	45	63
7/16" - 14	30	41	53	72	75	100
1/2" - 13	45	61	80	110	115	155
9/16" - 12	70	95	115	155	165	220
5/8" - 11	95	128	160	215	220	305
3/4" - 10	165	225	290	390	400	540
7/8" - 9	170	230	420	570	650	880
1" - 8	225	345	630	850	970	1320
1 1/8" - 7	354	478	794	1072	1287	1737
1 1/4" - 7	500	675	1120	1512	1875	2531
1 3/8" - 6	655	884	1470	1985	2382	3216
1 1/2" - 6	870	1175	1950	2632	3161	4267

See page 10 for Torque Specifications for Fine Threads and Head Markings

Torque Specifications for Fine Threads

Diameter "A"	Bolt Torque					
	SAE-2		SAE-5		SAE-8	
	LB-FT	N.m	LB-FT	N.m	LB-FT	N.m
1/4" - 28	6	8	10	14	14	19
5/16" - 24	12	16	19	26	27	36
3/8" - 24	22	31	35	47	49	66
7/16" - 20	36	49	55	74	78	105
1/2" - 20	55	74	85	115	120	162
9/16" - 18	80	108	122	165	172	232
5/8" - 18	110	148	170	230	240	324
3/4" - 16	200	270	297	400	420	567
7/8" - 14	180	243	474	640	668	402
1" - 12	274	370	705	952	995	1343
1" - 14	280	378	721	973	1019	1376
1 1/8" - 12	397	536	890	1201	1444	1950
1 1/4" - 12	553	747	1241	1675	2012	2716
1 3/8" - 12	746	1007	1672	2257	2712	3661
1 1/2" - 12	979	1322	2194	2962	3557	4802

Head Markings

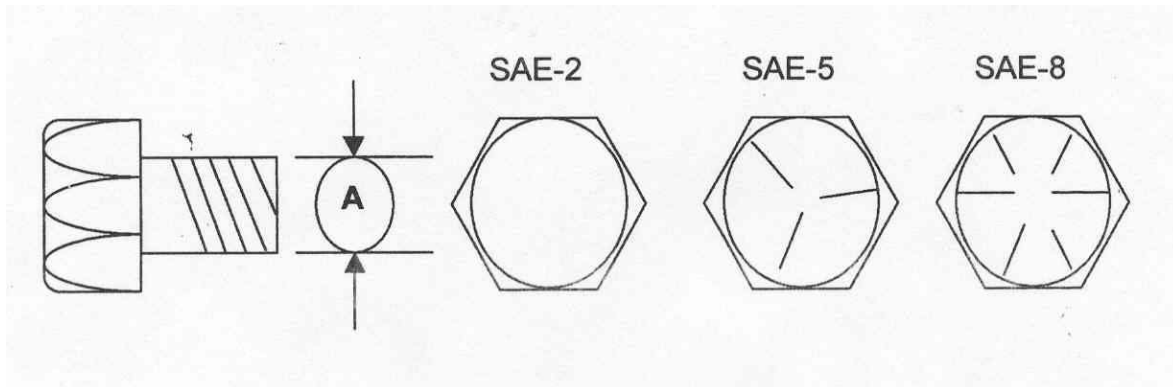

Hardee by EVH Manufacturing Co., LLC Limited Warranty

Hardee by EVH Manufacturing Co., LLC warrants its **Equipment*** for one year to the **original** non-commercial, non-governmental, or non-municipal purchaser. For the **original** commercial, industrial, or municipal purchaser, the goods are warranted for 90 days to be free from defects in material or workmanship.

Special OMNI Gearbox Warranty:

OMNI Gearboxes are warranted for a total of:

3 years to the original non-commercial user

1 year to the original commercial user

This limited warranty does not apply to any part of the goods which have been subjected to improper or abnormal use, negligence, alteration, modification, accident, or damage due to lack of maintenance, wrong oil or lubricants, or which has served its normal life.

The Warranty Card **must** be filled out and returned within **30 days** of purchase. **No** warranty will be allowed without a properly completed and returned warranty card.

“Our obligation under this warranty shall be limited to repair or replacement of any part or parts of this implement, which in our judgement, shows evidence of such defect, and provided further, that said parts shall be removed and returned by the owner at the owner’s expense to Hardee by EVH Manufacturing Co., LLC, Loris, SC, through an authorized dealer, transportation prepaid, free and clear of liens or encumbrances.”

This warranty shall not include normal wear items.

Changes or alterations to the implement made without the **written** authorization of the manufacturer will render this warranty void.

This warranty does not obligate this company to bear any labor costs in replacement of defective parts.

Hardee by EVH Manufacturing Co., LLC reserves the right to make changes or improvements in its equipment at any time, with the express understanding that such changes or improvements do not impose any obligation of the company to install such changes or improvements on implements previously manufactured.

IMPLIED WARRANTIES: You may have some implied warranties. For example, you may have an implied warranty of merchantability (that the unit is reasonably fit for the general purpose for which it was sold) or an implied warranty of fitness for a particular purpose (that the unit is suitable for your special purposes). Special purposes must be specifically disclosed to Hardee by EVH Manufacturing Co., LLC and not merely to the dealer before your purchase. Hardee by EVH Manufacturing Co., LLC itself must approve, in writing, that the special purpose is warrantable.

These implied warranties do not apply at all if you use your equipment for business or commercial use.

***See separate Hydraulic Mower Limited Warranty for Hydraulics**

NOTES:



EVH MANUFACTURING COMPANY, LLC
4895 RED BLUFF ROAD LORIS, SC 29569
PHONE: 843-756-2555 OR 1-888-990-2555
WWW.HARDEEBYEVH.COM EVHMFG@HARDEEBYEVH.COM