

ITEM NO.	PART NUMBER	QTY REQD.	NOMENCLATURE OR DESCRIPTION
1	10098	5	HEX BOLT (5/8" X 5")
2	10099	1	HEX BOLT ( 5/8" X 5-1/2")
3	10166	26	LOCK NUT ( 5/8)
4	10172	4	HEX HEAD LOCKNUT ( 1-1/8)
5	10339	2	RIVET, (1/8" X 3/8")
6	10469	2	HITCH PIN W/CLIP, CAT 1, 7/8" X 4-1/4"
7	10901	2	BUMPER CAP (FRONT)
8	10902	4	HALF SPOOL 4-1/2"
9	10906	8	BEARING SPACER
10	10907	4	NUT WASHER
11	10911	18	20" DISC BLADE 1-1/8" HOLE
12	10916	2	GANG BOLT 30-3/4"
13	10917	2	GANG BOLT 34-1/2"
14	10918	4	HALF SPOOL 6"
15	10919	4	SPOOL 9"
16	11032	3	HARDEE LOGO DECAL
17	11058	2	DECAL FOR D-18-1820
18	11636	1	LANDSCAPE & DISC HARROW SAFETY DECAL
19	11727	1	HARDEE SERIAL NUMBER PLATE
20	11850	1	WEB SITE DECAL
21	15450	16	CARRIAGE BOLT (5/8" X 5")
22	15465	4	TUBING INSERT, 3" 5-8 GAGE
23	15852	2	DECAL RED REFLECTOR
24	15853	2	DECAL YELLOW REFLECTOR
25	60023	8	CLAMP CAP FOR D-18, D-20
26	60024	4	PLATE WELDMENT
27	60029	1	GANG PIN REAR, WELD.
28	60037	4	NUT LOCK
29	60038	1	GANG PIN FRONT, WELDMENT
30	60050	2	BEAM, GANG (35")
31	60065	1	MAIN FRAME WELDMENT D-18
32	60080	2	40" GANG BEAM
33	60081	2	BUMPER CAP, SLOTTED (REAR)
34	60126	1	A-FRAME WELD.(D-18 & D-20)
35	60133	1	A- FRAME BRACE WELD.
36	60275	4	LEFT AXLE HANGER ASSEMBLY
37	60276	4	RIGHT AXLE HANGER ASSEMBLY
38	10905	4	SPOOLS 7 1/2"

DWG. NO.			REV.	
60100			G	
REV	CHANGE	BY	DATE	ECN
A	ADD LOGO AND MODEL DECALS	M.J.T.	5/21/99	0613
B	MRP B.O.M. CHANGES	T.O.B.	12/13/99	0698
C	MRP B.O.M. CHANGES	T.R.M.	6/12/00	0792
D	MRP B.O.M. CHANGES	R.T.N.	3/25/03	0949
E	MRP B.O.M. CHANGES	T.R.M.	3/23/04	0958
F	REASSEMBLED 60100	J.S.S.	3/17/09	1289
G	REASSEMBLED 60100	J.S.S.	5/4/09	1305

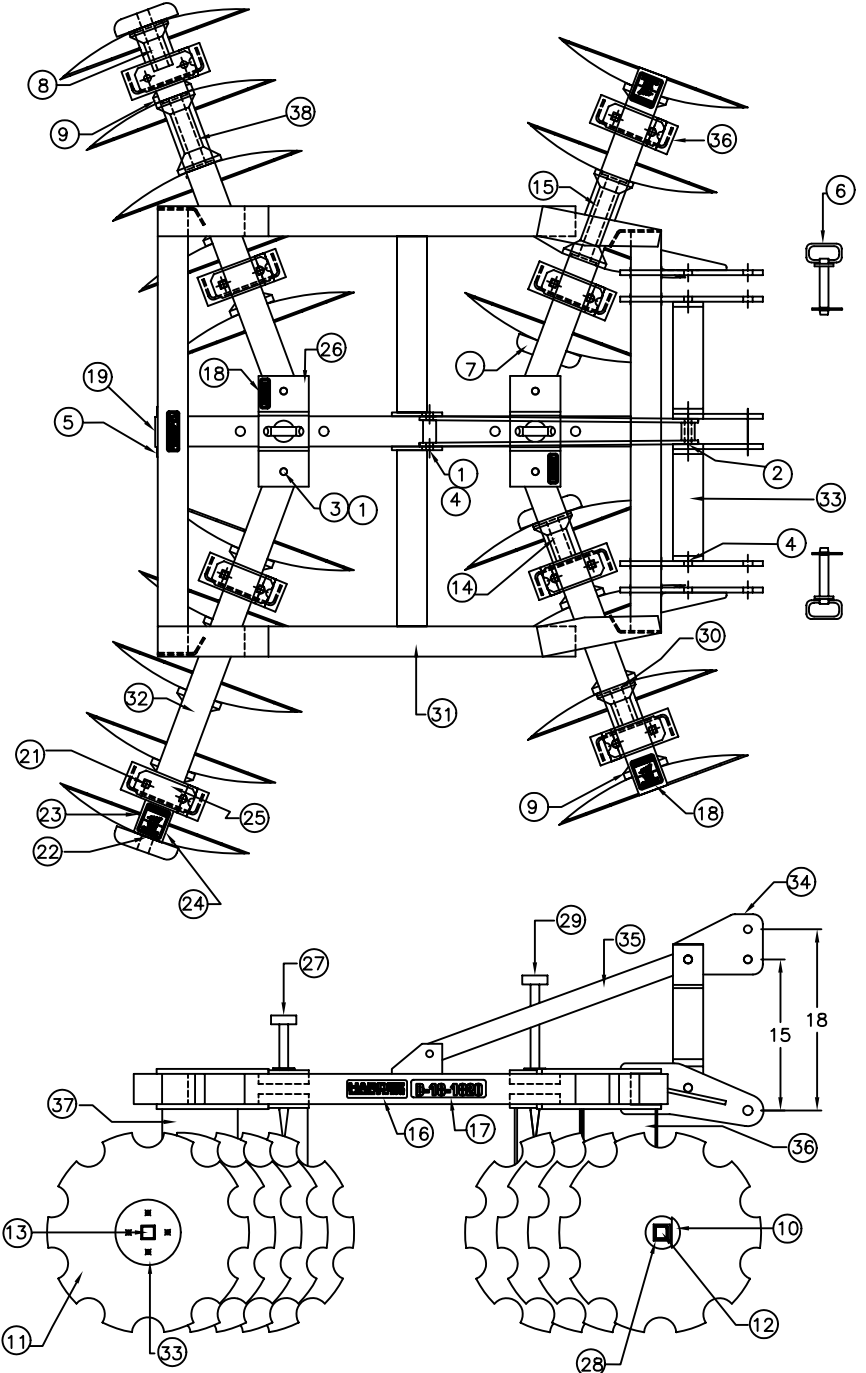

All Dimensions in Inches Unless Otherwise Specified  
 Dimensions in [ ] are in Millimeters  
 Tolerances Unless Otherwise Specified  
 Fractional Dimensions ±1/16" Angular Dimensions ±1°  
 Decimal Dim. to Limits Shown All holes to be +0/-1/32

DRAWN BY	J.S.S.	3/17/09
CHECKED BY		
MATERIAL	R.M.N.	---
MANUFACTURED BY: EVH MFG. CO., LLC		

<b>HARDEE BY EVH MFG. CO., LLC LORIS S.C.</b>	
APPLICATION DISC HARROW	OLD PART # ----
DESCRIPTION D-18-1820 ASSEMBLY	
DO NOT SCALE	DWG. NO. A SHT 1 OF 1 60100