

ITEM NO.	PART NUMBER	QTY REQD.	NOMENCLATURE OR DESCRIPTION
1	25340	1	CENTER DECK WELDMENT
2	20236	2	ROUND BLADE HOLDER WELD.
3	21548	1	RIGHT HITCH MOUNT WELDMENT
4	21541	1	LEFT HITCH MOUNT WELDMENT
5	21555	2	9.5" LEVELING ROD WELDMENT
6	25383	1	HITCH MEMBER WELDMENT
7	25436	1	SPRING ROCKER WELDMENT
8	25369	1	PULL TYPE HITCH WELDMENT
9	25453	1	FLOATING HITCH WELDMENT
10	25455	2	72" LEVELING ROD WELDMENT
11	25413	2	DUAL SPINDLE WELDMENT
12	25411	2	STAND WELDMENT
13	25410	2	T/W PLATE WELDMENT
14	25406	2	CENTER T/W ARM WELDMENT
15	25396	1	SINGLE SPINDLE WELDMENT
16	25399	1	CENTER TAIL WHEEL WELDMENT
17	25388	1	TAIL WHEEL ARM WELDMENT
18	25484	1	SAFETY SHIELD
19	25342	1	RIGHT DECK WING WELDMENT
20	10618	1	JACK FOR PULL TYPE CUTTER
21	10617	2	TURN BUCKLE 1" NPT.
22	25535	1	HINGE ROD
23	25449	1	DRIVE SHAFT SAFETY BRACKET
24	25465	2	DECK TRANSPORT BRACKET
25	10609	1	WING DRIVE SHAFT
26	10336	5	GEAR OIL (12.5)
27	10611	1	DRIVE SHAFT COMPLETE
28	25475	1	CENTER DECK SHIELD
29	25477	1	CENTER GEAR BOX SHIELD
30	10425	2	BLADE
31	25457	1	HOSE ROD
32	25456	1	HOSE ROD
33	20031	2	ACCESS COVERS
34	25422	2	COLLAR
35	25462	1	HYD. CYLINDER LINK
36	25117	2	SPACER
37	25463	1	RACHET JACK MNT. PLATE
38	20440	1	SLIDE

DWG. NO.			REV.	
25515			B	
REV	CHANGE	BY	DATE	ECN
IR	INITIAL RELEASE	B.C	4/28/07	---
A	CYLINDER STOP KIT ADDED (15222)	T.B.B.	10/7/15	1634
B	P/N 16747 < 3 X 17 Cyl. > Was 10448	C.K.N.	1/19/17	1655

39	23158	2	SPACER
40	25481	2	SPACER
41	25458	2	SPRING/DECK MOUNT WELD.
42	25466	1	RACHET JACK WELDMENT
43	25470	1	RACHET JACK BRACE WELDMENT
44	10696	2	SPRING (5 1/2" LG.)
45	25479	1	LOCK NUT 1 1/4" WELDMENT
46	25429	1	PIN 3/4" X 5" WELDMENT
47	25425	3	PIN 1" X 5" WELDMENT
48	25433	1	PIN 1" X 3 1/2" WELDMENT
49	25097	2	SPACER (3/4" LG.)
50	25427	1	PIN 1" X 4 1/2" WELDMENT
51	25109	3	PIN 1" X 6 1/2" WELDMENT
52	25118	4	SPACER SPECIAL
53	10205	3	5/8" FLAT WASHER
54	10390	10	CLIP PIN 2"
55	10391	10	CLIP PIN 3"
56	10311	4	BLADE BOLT NUT 1 1/4"
57	25573	1	CYLINDER
58	16747	1	CYLINDER
59	11752	2	SIDE MODEL # DECAL
60	10312	4	BLADE LOCK WASHER
61	10598	1	CENTER DIVIDER GEARBOX
62	11727	1	SERIAL NUMBER PLATE
63	10339	2	RIVETS
64	10313	4	BLADE BOLT 1 1/4"
65	11010	2	HARDEE LOGO DECAL
66	10440	5	GREASE SEAL
67	10437	5	INNER BEARING
68	10442	5	INNER CUP

All Dimensions in Inches Unless Otherwise Specified
Dimensions in [] are in Millimeters

Tolerances Unless Otherwise Specified
Fractional Dimensions $\pm 1/16"$ Angular Dimensions $\pm 1'$
Decimal Dim. to Limits Shown All holes to be $\begin{matrix} +0 \\ -1/32 \end{matrix}$

DRAWN BY	B.C	4/30/07	EVH MANUFACTURING CO LORIS S.C.	
CHECKED BY				
MATERIAL	R.M.N.		APPLICATION T-9510-PTW	OLD PART # ----
MANUFACTURED BY: EVH MANUFACTURING CO			DESCRIPTION T-9510-PTW ASSEMBLY	
DO NOT SCALE	A DWG SIZE	DWG. NO. SHEET 1 OF 4	25515	

ITEM NO.	PART NUMBER	QTY REQD.	NOMENCLATURE OR DESCRIPTION
69	25203	5	HUB KIT
70	25419	6	3/4 X 2 1/8 PIN WELDMENT
71	10471	30	STUD
72	10441	5	OUTER CUP
73	10438	5	OUTER BEARING
74	10211	5	3/4 I.D. X 2 O.D. FLAT WASHER
75	10179	5	3/4 CASTLE NUT
76	10246	5	COTTER PIN (PLATED)
77	10439	5	DUST CAP
78	10134	3	BOLT 1" X 5 1/2"
79	10171	5	LOCK NUT 1"
80	10322	1	GREASE FITTING
81	10393	2	CLEVIS PIN UNIVERSAL
82	10111	5	BOLT 3/4" X 2"
83	10168	31	LOCK NUT 3/4"
84	10186	33	LOCK WASHER 3/4"
85	10110	4	BOLT CENTER BOX
86	10335	3	PAINT (3 GAL)
87	10119	8	BOLT 3/4" X 6"
88	20356	4	BOLT 3/4" X 2" (SPECIAL)
89	25421	2	BUSHING
90	10206	4	FLAT WASHER 3/4"
91	10424	2	BLADE
92	10260	6	PLOW BOLT 1/2" X 1 1/2"
93	10184	14	LOCK WASHER 1/2"
94	10176	19	LOCK NUT 1/2"
95	10243	5	COTTER KEY 5/32" X 2"
96	10077	1	BOLT 1/2" X 4"
97	10017	2	BOLT 5/16" X 1"
98	10161	2	NUT 5/16"
99	10072	10	BOLT 1/2" X 1 1/2"
100	10150	30	LUG NUT
101	13905	2	6-M-JIC X 8-M-NPT ELBOW
102	13906	2	6-M-JICX8-M-NPT ELBOW W/ORIFICE
103	25447	2	REPLACEABLE SLIDE
104	10207	1	FLAT WASHER 1"
105	25482	16	HINGE ASSEMBLY FOR WING
106	25513	16	HINGE ASSEMBLY FOR CENTER

DWG. NO.			REV.	
25515			B	
REV	CHANGE	BY	DATE	ECN
IR	INITIAL RELEASE	B.C	4/28/07	---
A	CYLINDER STOP KIT ADDED (15222)	T.B.B.	10/7/15	1634
B	P/N 16747 < 3 X 17 Cyl. > Was 10448	C.K.N.	1/19/17	1655

107	25485	1	SKID CLOSURE WELDMENT
108	25490	1	WEIGHT BOX WELDMENT
109	25268	1	CYLINDER STOP WELDMENT
110	25117	12	SPACER (NOT SHOWN)
111	15522	1	CYLINDER STOP KIT

All Dimensions in Inches Unless Otherwise Specified
Dimensions in [] are in Millimeters

Tolerances Unless Otherwise Specified
Fractional Dimensions ±1/16" Angular Dimensions ±1"
Decimal Dim. to Limits Shown All holes to be ⁺⁰/_{-1/32}

DRAWN BY	W.E.S.	01/05/99	EVH MANUFACTURING CO LORIS S.C.	
CHECKED BY				
MATERIAL		R.M.N.	APPLICATION T-9510-PTW	OLD PART # ----
MANUFACTURED BY: EVH MANUFACTURING CO			DESCRIPTION T-9510-PTW ASSEMBLY	
DO NOT SCALE	A	DWG. NO.	SHEET 2 OF 4	
	DWG SIZE	25515		

DWG. NO.		25515		REV.	B
REV	CHANGE	BY	DATE	ECN	
IR	INITIAL RELEASE	B.C	4/28/07	----	
A	CYLINDER STOP KIT ADDED (15222)	T.B.B.	10/7/15	1634	
B	P/N 16747 < 3 X 17 Cyl. > Was 10448	C.K.N.	1/19/17	1655	

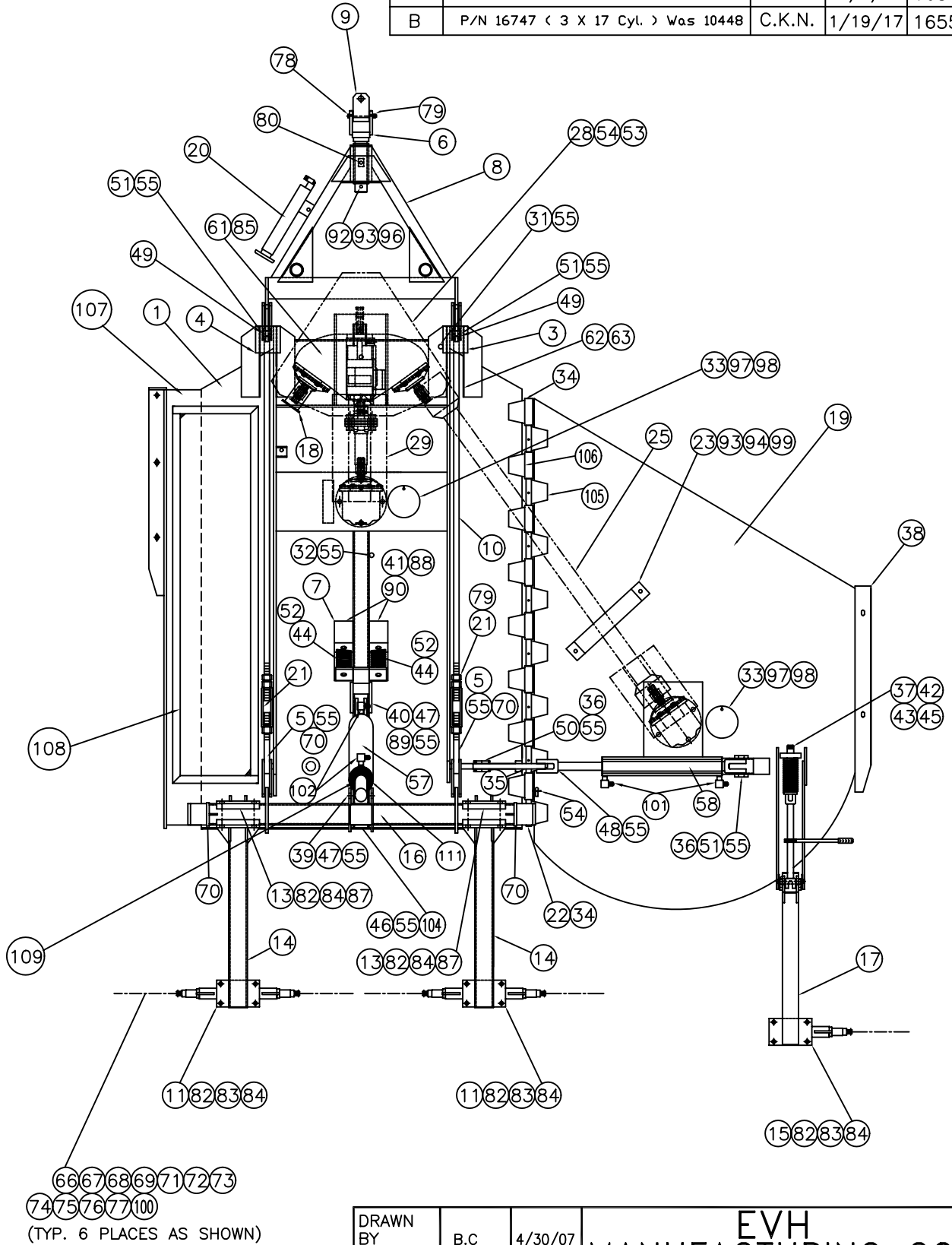

66 67 68 69 71 72 73
74 75 76 77 100
(TYP. 6 PLACES AS SHOWN)

DRAWN BY	B.C	4/30/07	EVH MANUFACTURING CO LORIS S.C.	
CHECKED BY				
MATERIAL	R.M.N.		APPLICATION	OLD PART #
MANUFACTURED BY: EVH MANUFACTURING CO			T-9510-PTW	----
			DESCRIPTION T-9510-PTW ASSEMBLY	
DO NOT SCALE	A	DWG. NO.	25515	
	DWG SIZE	SHT. 3 OF 4		

All Dimensions in Inches Unless Otherwise Specified
Dimensions in [] are in Millimeters

Tolerances Unless Otherwise Specified
Fractional Dimensions $\pm 1/16"$ Angular Dimensions $\pm 1^\circ$
Decimal Dim. to Limits Shown All holes to be $\begin{matrix} +0 \\ -1/32 \end{matrix}$

DWG. NO.

25515

REV.

B

REV	CHANGE	BY	DATE	ECN
IR	INITIAL RELEASE	B.C	4/28/07	---
A	CYLINDER STOP KIT ADDED (15222)	T.B.B.	10/7/15	1634
B	P/N 16747 < 3 X 17 Cyl. > Was 10448	C.K.N.	1/19/17	1655

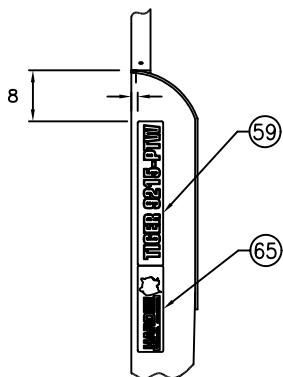

VIEW B
VIEW SHOWS RIGHT END VIEW
OF DECK SIDE ONLY FOR
PLACEMENT OF LOGO AND MODEL
NUMBER DECALS

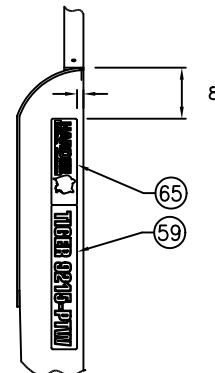

VIEW A
VIEW SHOWS LEFT END VIEW
OF DECK SIDE ONLY FOR
PLACEMENT OF LOGO AND MODEL
NUMBER DECALS

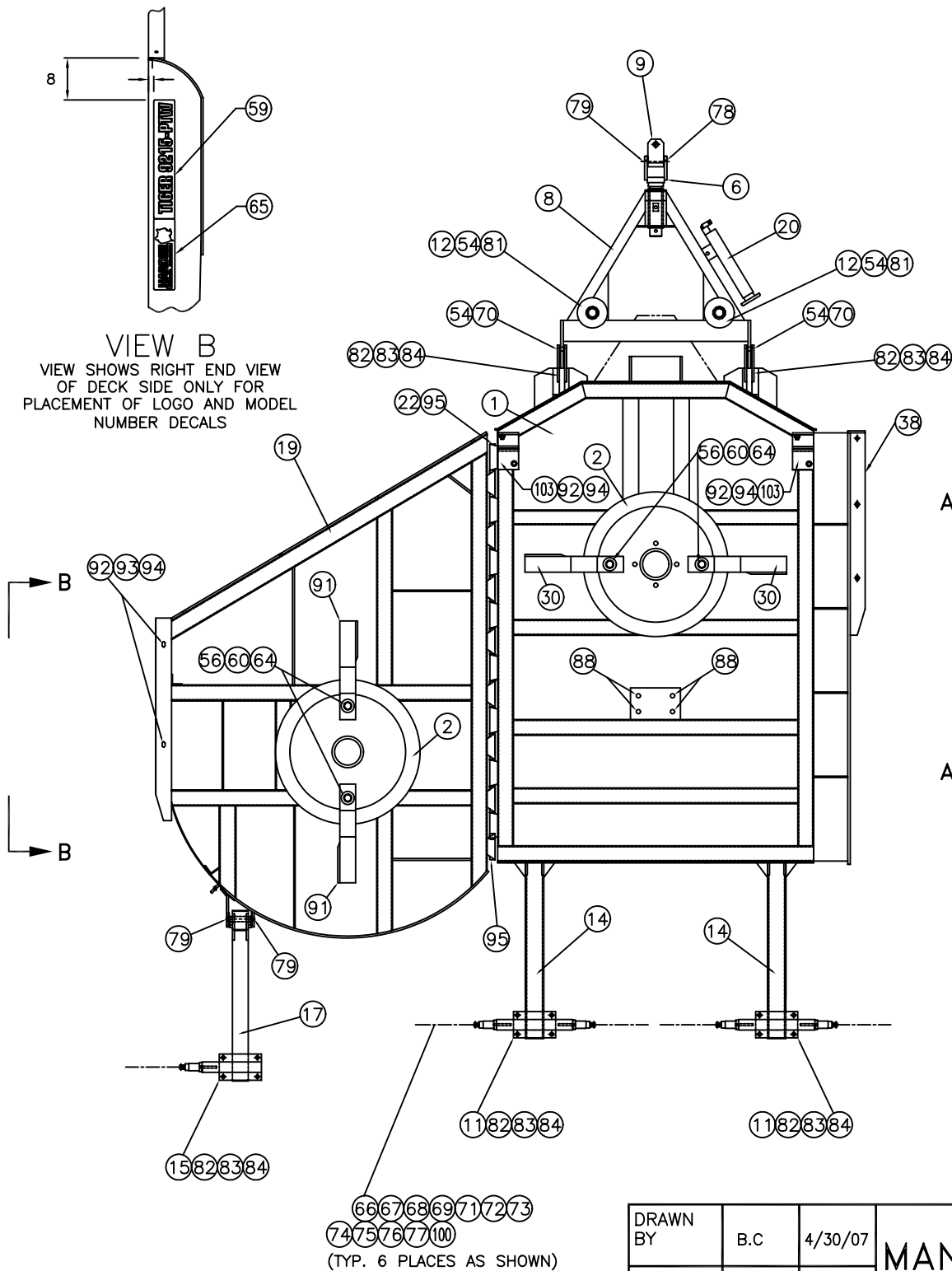

All Dimensions in Inches Unless Otherwise Specified
Dimensions in [] are in Millimeters

Tolerances Unless Otherwise Specified
Fractional Dimensions $\pm 1/16"$ Angular Dimensions $\pm 1^\circ$
Decimal Dim. to Limits Shown All holes to be $\begin{matrix} +0 \\ -1/32 \end{matrix}$

DRAWN BY	B.C	4/30/07
CHECKED BY		
MATERIAL	R.M.N.	
MANUFACTURED BY:	EVH MANUFACTURING CO	

EVH MANUFACTURING CO	
LORIS S.C.	
APPLICATION T-9510-PTW	OLD PART # ----
DESCRIPTION T-9510-PTW ASSEMBLY	
DO NOT SCALE	A DWG SIZE
DWG. NO. SHT. 4 OF 4	25515