



**OPERATOR'S AND MAINTENANCE MANUAL**

**WITH PARTS LISTING**

**Hydraulic Rotary Mower**

**Model: MITI MIKE - 35**

**FOR SERIAL #s STARTING**

**WITH 012436**

**RELEASED 04/15/16**



**DANGER**  
*Read this manual and the manual for  
your tractor carefully to acquaint yourself  
with both machines before operating!*

**MODEL NUMBER** \_\_\_\_\_  
**SERIAL NUMBER** \_\_\_\_\_  
**DATE OF PURCHASE** \_\_\_\_\_

Customer Pre-Operation Check List		Reference
<input type="checkbox"/>	<b>Read, understand and follow the general safety rules listed in this manual.</b>	<b>Page 2</b>
<input type="checkbox"/>	<b>Check all shields and guards.</b>	<b>Page 2</b>
<input type="checkbox"/>	<b>Attach pump to PTO shaft of tractor.</b>	<b>Page 8</b>
<input type="checkbox"/>	<b>Add ballast to the rear tractor tires and space them to the widest setting.</b>	<b>Page 8</b>
<input type="checkbox"/>	<b>Add ballast and front weights to your tractor, if needed.</b>	<b>Page 8</b>
<input type="checkbox"/>	<b>The Hydraulic and Operational System Setup.</b>	<b>Page 9</b>
<input type="checkbox"/>	<b>Working safely with hydraulic lines.</b>	<b>Page 9</b>
<input type="checkbox"/>	<b>Check all fluid levels, tractor and cutter.</b>	<b>Page 10</b>
<input type="checkbox"/>	<b>Check all grease fittings.</b>	<b>Page 12</b>
<input type="checkbox"/>		

**Service Notice**

**Please take extra care while servicing the hydraulic system by keeping all openings properly covered, thus preventing contamination of the hydraulic components. Contaminants in the oil WILL cause faulty operation or premature failure of components in the hydraulic control valve, pump, and motor.**

**Disclaimer**

**THIS CUTTER IS NOT DESIGNED TO CUT TREES.** The cutter is designed to cut grass and small brush smaller than 1/2" in diameter.

Any modes of operation other than the ones described above, **shall void the warranty.** Moreover, HARDEE by EVH Manufacturing Company, LLC **does not accept and liability to any person and/or material when the cutter is operated in violation of the above information.**

## Table of Contents

<b>Section 1 Introduction</b>	1	Replacement	12
To Our Customers	1	Routine Maintenance Checklist	13
Owner's Responsibility	1	<b>Section 6 Troubleshooting</b>	14
Purpose Of This Manual	1	Troubleshooting Guide	14-15
Safety-Alert Symbol	1	<b>Section 7 Specifications</b>	15
Signal Words	1	Summary Of Specifications	16
Customer Assistance	1	<b>Section 8 Replacement Parts</b>	17-20
<b>Section 2 Safety Information</b>	2	<b>Section 9 Reference</b>	21-23
General Safety Rules	2	Bolt Torque	21-23
Safety Decals	3-6	Checking Bolt Torque	21-23
<b>Section 3 Assembly And Installation</b>	7	<b>Section 10 Warranty</b>	24
Component Identification And Terminology	7		
Tractor Requirements	8		
Pump Installation	8		
Tractor Hook-Up Procedures	8		
Hydraulic Hose Hook - Up	9		
Hydraulic System And Operational Setup	9		
Working Safely With Hydraulic Lines	9		
<b>Section 4 Operation Instruction</b>	10		
During Operation	10		
Daily Start-Up Checklist	10		
Operation Environment	10		
Application Do's And Don'ts	10		
Using Your Cutter	11		
Getting Started	11		
Unhook And Post Use Care	11		
Unhooking The MITI MIKE - 35	11		
Post Use Care	11		
<b>Section 5 Maintenance</b>	12		
Maintenance And Service Schedule	12		
Inspection And Replacement Of Blades	12		
Inspection And Replacement Of Blade Holder	12		
Inspection	12		

## Introduction

### To Our Customers

We, at Hardee by EVH Manufacturing Company, thank you for buying your new Hydraulic Rotary Cutter.

We have labored hard to build a mower to do the work you have in mind. Many hours of engineering, field-testing and improvement have gone into the design and fabrication of your mower. We will strive to continue this quality of manufacturing in the future, always keeping the customer's needs clearly in mind.

The best performance of your mower will depend on you. Proper lubrication, maintenance, hookup, adjustments and operation are essential for it to give you long and dependable service. However, as with any type of equipment, your mower is designed to perform specific functions.

In this manual, you will find instructions on mower features, maintenance and operation. If customer service or repair parts are required, contact your local Hardee dealer. **PLEASE SPECIFY MODEL AND SERIAL NUMBER WHEN ORDERING PARTS.**

### Owner's Responsibility

The manufacturer has no control over the ultimate use of the mower and therefore assumes no responsibility or liability for damage or injury resulting from the use of this machine.

The upkeep of the hydraulic mower is the responsibility of the user. This upkeep includes all shielding, guards, and safety decals (OSHA Regulation 1928.57). You can obtain replacement parts from any authorized Hardee dealer.

Read this Operator's Manual before operating the mower. Failure to do so could result in injury to the operator or to others. Remember that most accidents occur due to neglect or carelessness. The operator is responsible for inspecting and making repairs as may be necessary. Cleaning after each use and storage under a shelter will extend the life of the mower.

### Purpose of This Manual

This manual provides information on safety, operation, adjustments, troubleshooting and maintenance of your new mower. Please read and follow all the recommendations to help ensure that you get many years of service from your new Hardee mower.

If you need additional copies of this manual, please contact your local Hardee dealer or download a copy from our website at [www.hardeebyevh.com](http://www.hardeebyevh.com).

### Safety-Alert Symbol



This symbol is the safety alert symbol. It appears throughout this manual to call your attention to instructions involving your personal safety and the safety of others. Failure to follow these instructions can result in injury or death.

### Signal Words

Safety signal words are words that call attention to the safety sign and designate a degree or level of hazard seriousness. The signal words used throughout this manual are DANGER, WARNING and CAUTION. Please read and follow all safety messages that have these signal words shown for your protection.



#### **DANGER**

Indicates an imminently hazardous situation which, if not avoided, will result in death or serious injury.



#### **WARNING**

Indicates a potentially hazardous situation which, if not avoided, could result in death or serious injury.



#### **CAUTION**

Indicates a potentially hazardous situation which, if not avoided, may result in minor or moderate injury.

### Customer Assistance

The Hardee sales team would like you to be satisfied with your new Hydraulic Rotary Mower. If for some reason you have any questions about the information in this manual or have a problem with your mower, please discuss the problem or question with the management of your local dealership. If further assistance is required, please contact:

**HARDEE BY**  
**EVH Manufacturing Company, LLC**  
**Sales Department**  
 4895 Red Bluff Road  
 Loris, SC 29569  
 843-756-2555

## Safety Information

### General Safety Rules

This section of your manual will address the safe operation of your new mower. We at Hardee strive to produce a machine that is both a quality product and safe to operate. Please take the time to read, understand and follow the safety rules listed below and throughout this manual.

Your safety also depends on you becoming familiar with the basic operation of your new mower. You can find complete instructions for this mower in the Operation Instruction section of this manual. We believe that using your mower safely, in a safe environment will give you great results!

#### DANGER

This machine is designed for use on a closed cab tractor only! If your tractor has an open cab, then it **MUST** be equipped with operator protective equipment in the form of shielding from thrown objects and Roll Over Protective Structure (ROPS) to operate this equipment safely.

#### DANGER

Rotary mowers have the inherent ability to throw debris considerable distances when the blades are allowed to strike foreign objects. The operator must use caution or serious injury may result. Be sure bystanders are at a safe distance at all times when the mower is in use.

#### WARNING

Always keep your tractor level as you reach over ditches, etc. Be careful to keep ample distance between the rear tire and the top of the ditch bank to avoid a cave-in of the bank.

#### WARNING

Failure to keep the tractor level may result in loss of traction, tipping, rollover, property damage, personal injury or death.

#### WARNING

Never stand, or allow others to stand next to, or under the mower head at any time. Never park the unit without placing the cutterhead squarely and firmly on

the ground. Serious injury or death by crushing may occur in case of hydraulic failure.

#### DANGER

Do not look under the mower head or attempt to remove objects or branches from under the cutterhead while the tractor is running. Serious injury, loss of limb or death may result.

#### DANGER

Do not reach under the mower head at any time. Mowing blades may cause serious injury, loss of limb or disfigurement.

#### WARNING

Never use the mower for a lifting device of any kind. It is not designed for this purpose. Serious damage to unit may occur. Serious bodily injury may be incurred from this misuse.

#### WARNING

Never allow the mower to impact rock piles, piles of gravel, steel guardrails or concrete abutments. Contact with these objects could cause blade failure. Serious machine damage, property damage or bodily injury may occur. Check the area for these items before mowing.

### Safety Decals

Your Hardee mower ships with all safety decals in place. They are located in areas on the cutter that are potentially hazardous. Please locate, read and follow the information you find on these decals.

By law, you must replace any safety decals that are damaged or missing. You can order replacement decals from any local Hardee dealer. Just ask for part number 15845.

To apply the replacement decals:

- Clean the surface to place the new decal.
- Peel the decal away from the paper backing.
- Press firmly onto the clean surface.
- Squeeze out any air pockets using a straight edge.

**Safety Information**



**Weight Box - Back**



**Danger – Thrown Object**  
(On sheet - P/N 15845)



**Danger – Rotating Driveline**  
(On sheet – P/N 15845)



**Operating Safety and General Instruction**  
(On sheet – P/N 15845)



**Warning – Thrown Object**  
(P/N 11005)



**Weight Box – Front & Side**  
**USE “Miti Mike - 35”**  
**(P/N 16576) &**  
**Hardee DECALS**  
**(P/N 11032)**

## Safety Information

### Safety Decals, continued

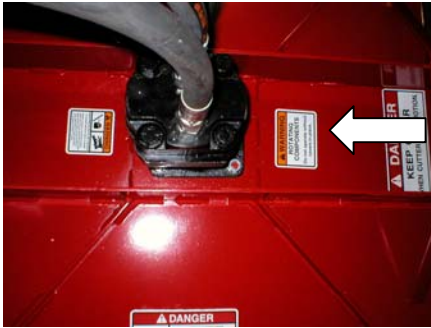

Deck



Warning – Rotating Components  
(On sheet – P/N 15845)



Weight Box



Danger – Crushing Hazard  
(On sheet – P/N 15845)



Hitch Frame



Warning – High Pressure Fluid Hazard  
(On sheet – P/N 15845)



Hitch Frame



Deck

### Safety Information

Safety Decals, continued



Deck



Danger – Keep Clear  
(On sheet – P/N 15845)



Hitch Frame

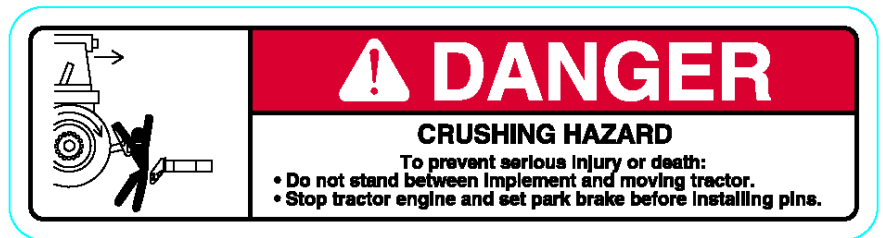

Danger – Crushing Hazard  
(On sheet – P/N 15845)



Hitch Frame



Warning – Pinch Point  
(On sheet – P/N 15845)



Hitch Frame

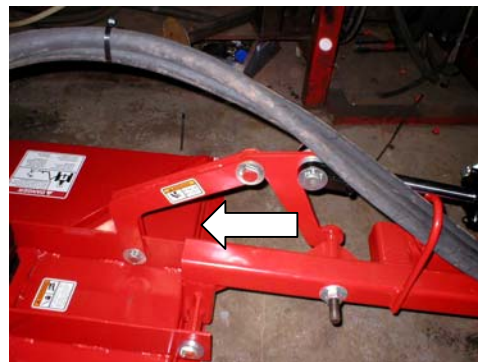

Deck link (both sides)



**Safety Information**

Safety Decals, continued

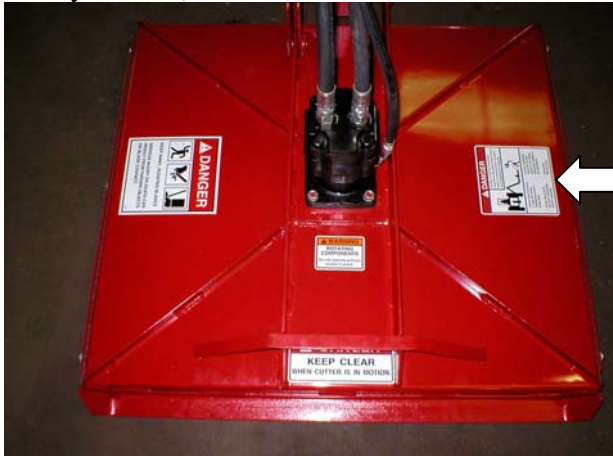

**Deck - Front**



**Danger – Thrown Object**  
(On Sheet – P/N 15845)

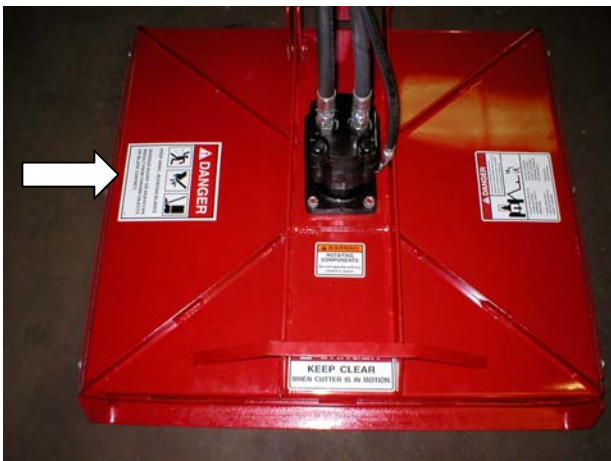

**Deck – Rear**



**Danger – Keep Away Rotating Blades**  
(P/N 11001)



**Weight Box – Front/Back**

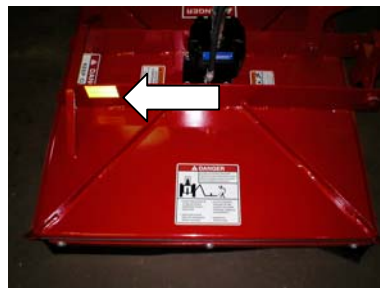

**Deck – Front/Rear**

- 15852 – Red Reflector, Rear (Not Shown)
- 15853 – Yellow Reflector, Front

**Assembly and Installation**

**Component Identification and Terminology**

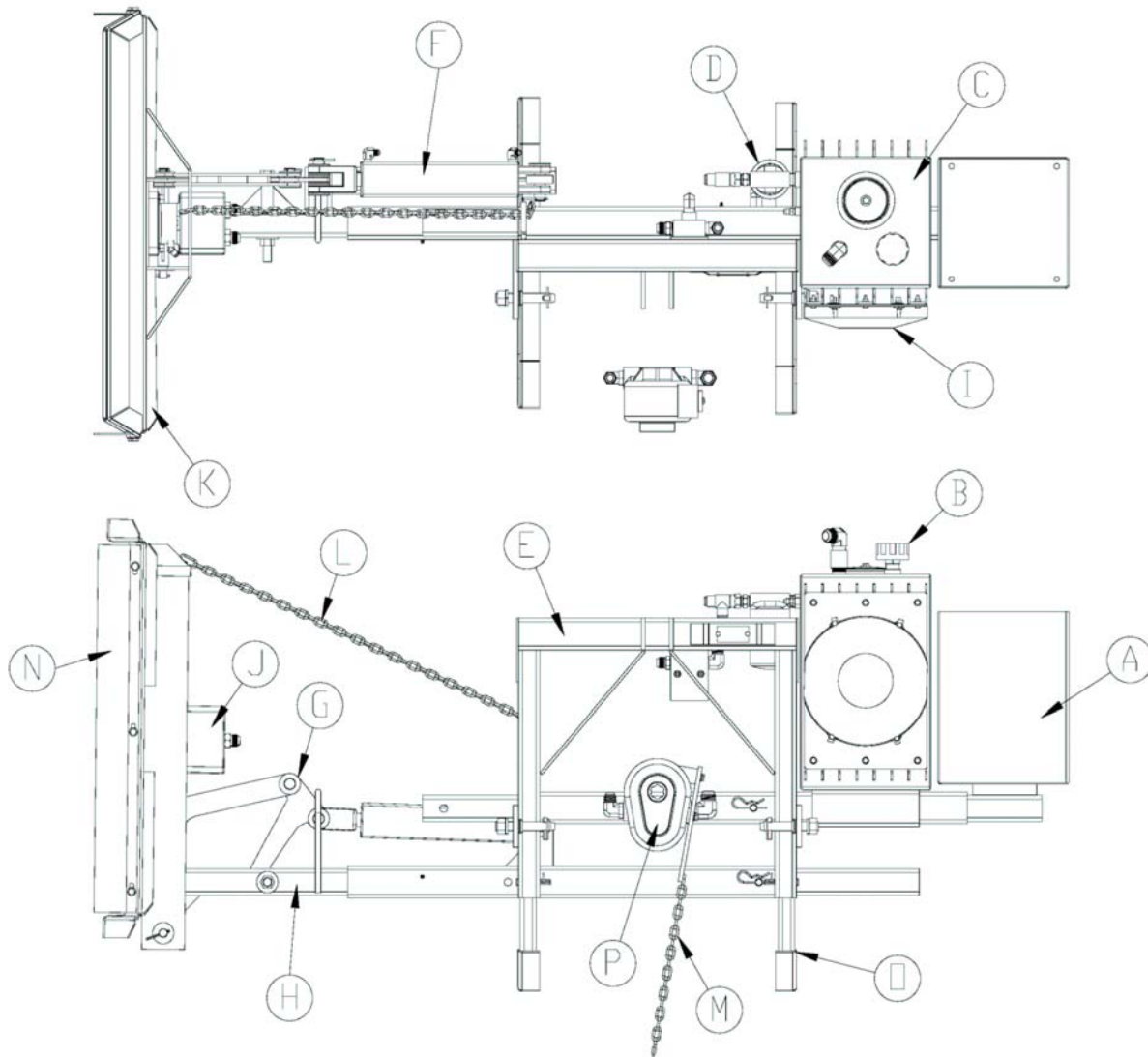

A	Weight Box	I	Fan- Oil Tank
B	Dipstick	J	Hydraulic Motor
C	Oil Tank	K	Deck
D	Return Filter	L	Shipping/Storage Chain
E	Hitch Frame	M	Pump Stabilizer
F	Deck Cylinder	N	Rubber Shielding
G	Link - Cylinder	O	Stand Weldment
H	Extension Arm	P	Hydraulic Pump

## Assembly and Installation

### Tractor Requirements

The Hydraulic Rotary Mower you have purchased is designed for use with 22 - 34 horsepower, Compact Tractor. The above tractor must be equipped with a 540 RPM rear power take-off (PTO) and one set of hydraulic remotes.

Your tractor must also be equipped with a standard category 1 hitch.



To ensure stability of your tractor, the rear tires should be spaced at their widest setting. You should also add ballast to maintain proper steering control and balance. In addition, you may also need to add front weights. Please refer to the operator's manual for your tractor to determine the correct setup.



#### **DANGER**

*This machine is designed for use on a closed cab tractor only! If your tractor has an open cab, then it MUST be equipped with operator protective equipment in the form of shielding from thrown objects and Roll Over Protective Structure (ROPS) to operate this equipment safely.*

### **Hydraulic Pump Installation on to the tractors PTO Shaft**

Refer to Figure 1 for reference

- ✓ Install Hydraulic Pump on the PTO shaft of the tractor. Verify that the PTO shaft is fully engaged in pump.
- ✓ Secure the chain from the Pump Stabilizer to prevent the pump from spinning or sliding off the PTO shaft of the tractor. (MAKE SURE THE PUMP DOES NOT BIND WHEN LIFT ARMS MOVE UP AND DOWN OR SIDE TO SIDE)



**Figure 1**

### Tractor Hook-Up Procedures

- ✓ Hook tractor 3-point hitch to cutter hitch frame. The Miti Mike - 35 is designed to work with a standard 1 hitch.



#### **WARNING**

*Before leaving the tractor seat, always engage the tractor brake and/or set the transmission of the tractor in parking gear. Stop engine and remove key. Always make sure that no one is between the tractor and the mower when tractor is in motion.*

- ✓ Attach Hydraulic Pump to tractor (PTO Pump). (See below for instructions)
  - Verify that the PTO shaft is fully engaged in pump.
  - Verify that Pump Stabilizer is properly hooked.

### HYDRAULIC HOSE HOOK - UP



#### **DANGER**

*Never use hands or skin to check for hydraulic leaks, use cardboard or wood. High-pressure oil leaks can penetrate skin causing injury and gangrene. Always wear safety goggles when working around high-pressure lines.*

- Attach hoses to the cylinders and tractor remotes
- ✓ Raise jack/remove stands before moving mower.

## Assembly and Installation

### Hydraulic System and Operational Setup



#### IMPORTANT

The hydraulic system setup information contained in the following pages should be used only as a guide.

- Tractor lift should be in good working order.
- Check for moisture accumulation in hydraulic oil tank before operating mower.
- Check oil level. If oil is needed, HARDEE special hydraulic oil, part No. 23333, is recommended.
- Hydraulic Pump is Installed on the PTO shaft of the tractor.
  - ✓ Verify that the PTO shaft is fully engaged in pump. It should be tight and secure.
  - ✓ Secure the chain from the Pump Stabilizer to prevent the pump from spinning or sliding off the PTO shaft of the tractor. (MAKE SURE THE PUMP DOES NOT BIND WHEN LIFT ARMS MOVE UP AND DOWN OR SIDE TO SIDE)



#### CAUTION

- Before mowing, run mower a short time at a low speed to warm oil. Operate mower head in all mowing positions to make sure all moving parts are operating normally.
- To extend or retract mower extension arm Miti Mike - 35. Remove pin, side to desired position and reinstall pin in correct location. (Move Counter weight accordingly).



#### WARNING

Before leaving the tractor seat, always engage the tractor brake and/or set the transmission of the tractor in parking gear. Stop engine and remove key.

- To adjust mower head angle, activate deck cylinder (F) on page (7).
- Operate tractor PTO speed between 500 – 540 RPM's for best mowing results.
- Refrain from fast speeds over rough terrain.
- If mower stalls on heavy mowing, raise head to clear obstruction, and allow it to regain mowing speed.
- To prolong life of mower, store under shelter, to protect it from the weather.
- A stand weldment (page 7) is mounted to frame so mower may be stored with mower head in a down position.

If you have any questions, consult your local Hardee dealer.

### Working Safely with Hydraulic Lines

Purge all air from hydraulic system before attempting to raise or lower the mower deck, and extending or retracting the extension arm.



#### DANGER

Stand clear if lowering or raising deck, hydraulic deck can fall suddenly from system failure.



#### DANGER

Do not use your hand or skin to check for hydraulic leaks, use cardboard or wood. High-pressure oil leaks can penetrate skin causing injury and gangrene. Consult a doctor immediately.

### Hydraulic System and Operational Setup, continued...

# Operation Instruction

## Operation Instructions

### During Operation



#### WARNING

Ensure that all bystanders are clear of the mower before starting tractor engine. Objects thrown by the mower blades can cause severe personal injury or death.

Before any operation of the mower, be familiar with the locations and functions of the unit's controls. Being familiar with the mower and its controls will increase efficiency and reduce the possibility of serious injury or damage to the unit.

The operator should work slowly and carefully until he feels comfortable with the mower. Speed and skill will be attained much more easily if the necessary time is spent to familiarize yourself with the mower and its operation.

Get into the habit of completing a walkaround inspection before use. This procedure is a simple method of inspecting your unit's condition by walking around and looking at each component of the unit, including the tractor. This procedure has been used by airline pilots for many years as a final inspection before flight and is also used by long distance ground transportation drivers on buses and trucks. During the walkaround, you will visually search your unit's tire condition, look for hydraulic leaks, fuel leaks, inspect hose condition and condition of hydraulic cylinders. Look for loose or worn components, see that all guards are in place, check blade condition, look for broken or inoperative lights and determine that it is or is not operable before use. We recommend that you follow this procedure before start up.

Daily Start-Up Checklist		
	Check	Section
<input type="checkbox"/>	Check All Fluid Levels, Tractor & Mower, For best results, use Hardee hydraulic oil – part number 23333	Page 12
<input type="checkbox"/>	Grease Points	Page 12
<input type="checkbox"/>	Blade Tightness	Page 12
<input type="checkbox"/>		

## Operating Environment

### Application Do's and Don'ts

There are obvious and hidden potential hazards in operating this mower. **REMEMBER!** This machine is often operated in rough terrain conditions that include gullies, holes, slopes and hidden obstructions. Serious injury or even death may occur unless care is taken to assure the safety of the operator and bystanders in the area.

Included here is a list of safety messages, which should be followed. Observing these messages and using common sense learned from experience help eliminate the hazards of operating this and other machinery.



#### DANGER

Read this manual and the manual for the tractor carefully to acquaint yourself with both machines before operating. **REMEMBER,** power-driven equipment should be operated only by those trained and familiar with the operation and instructed to do so. Working with unfamiliar equipment or in unfamiliar conditions can lead to accidents.



#### WARNING

Before leaving the tractor seat, always engage the tractor brake and/or set the transmission of the tractor in parking gear. Stop engine and remove key.



#### DANGER

Never allow riders on tractor or equipment. Falling off can cause serious injury or death.



#### WARNING

Worn or dull cutter blades can cause excessive mower vibration resulting in damage to the gearbox and structural damage to the mower. You should replace or sharpen blades in pairs. Excessive vibration can cause rotating parts to break and fly off the mower, causing serious injury or death to the operator or bystanders.



#### DANGER

Do not modify or alter this machine or any of its components or any equipment function without consulting EVH Manufacturing Company.

## Operation Instruction

---

### Using Your Mower

#### Getting Started

You will need to spend some time getting the “feel” of your new mower. Spend time reviewing the following steps before using your mower for the first time. The time that you take will greatly enhance your ability to get the desired results when you begin mowing.

- ✓ Attach the mower to the tractor; see the hook-up procedures on page 8 for complete instructions. After you have the mower attached, double check to ensure that no part of the tractor is in contact with the mower deck.
- ✓ Next, follow the instructions for installing the Hydraulic Pump on page 8 of this manual.
- ✓ Check the blades for sharpness. Check the blade carrier bolts, both blade bolts for tightness and roll pins.



#### Danger

*Before proceeding, make sure that no other persons are in close proximity to the mower!*

- ✓ With all controls in neutral, the tractor in park, the throttle in idle position and the PTO off... Start the tractor engine.
- ✓ Practice using control valve levers to control the movement of the mower head.

After you feel comfortable with the basic mower control, the next step is to start the blades.

- ✓ Now carefully engage the tractor’s hydraulic system to detent position.
- ✓ With the mower under power, practice using control valve levers to control the movement of the mower head.
- ✓ Slowly increase the tractor throttle to a high idle speed.
- ✓ After the mower is running smoothly, increase the tractor to 540 PTO RPM and adjust the mower head to the mowing position.
- ✓ Release the tractor from park and put the transmission in low range. You are now in mowing mode and are underway.



#### Danger

*Do not change the blade rotation direction! Blades must rotate in the counter clockwise direction.*



#### Caution

You will do severe damage to your mower if you allow the boom arm to reach the bottoming-out point.

#### Unhook and Post Use Care

Before unhooking the tractor from your mower, always clean the unit thoroughly to remove grass, mud or debris, this mower should always be stored on a hard level surface.

#### Unhooking the MITI MIKE - 35

- ✓ To unhook from your unit, first lower the jack stand to the storage position.
- ✓ Lower the deck so that it rests firmly and evenly on the ground.
- ✓ Lower the tractor lift arms so that the mower will rest firmly on the jack stand.
- ✓ Be sure to relieve all hydraulic pressure on the deck before unhooking.
- ✓ Remove Hydraulic Pump from tractor PTO.
- ✓ Remove Hydraulic hoses from the tractor remotes.
- ✓ Unhook tractor hitch from 3-point frame on mower.

#### Post use care

- Never leave pump hanging down and touching the ground.

## Maintenance

---

### **Maintenance and Service Schedule**

This section is dedicated to the maintenance of the Miti Mike - 35. As with any piece of equipment, the performance and life span depends on the proper operation and maintenance.



#### **DANGER**

*Never attempt any checks, repairs or adjustments with tractor engine running or the power take-off engaged. Adjustment of rotating parts while the tractor engine is running can result in serious personal injury or death if the PTO accidentally engages.*

### **Extension Arms**

Inject with heavy multi-purpose grease. There are 2 grease fittings on the extension arm tube.

### **Inspection and Replacement of Blades**

The mowing blades on the Hardee mower are designed and made to exact specifications and should be replaced with only original Hardee parts. Always replace blades in pairs to retain balance on the blade holder. Never weld the blades, as this will change the temper of the steel. Never modify the blades. Replace as necessary.

When the replacement of mower blade is required, a few rules should be followed:

- Replace blades in pairs.
- Inspect bolt holes.
- If bolt holes are elongated, replace blade holder. *See instructions below.*
- Mowing heavy brush causes excess stress on the blade bolts, because of this they will require inspection that is more frequent.
- When replacing blades always replace bolts, nuts and roll pins. Never reuse blade bolts, nuts or roll pins.

### **Inspection and Replacement of Blade Holder**

#### **Inspection**

- ✓ First, completely extend deck. Rotate mower deck all the way up. Switch off tractor, secure parking brake and remove key.

- ✓ When inspecting, pay particular attention to any small hairline cracks between spindle bolt hole and blade bolt holes. This indicates metal fatigue from severe abuse and blade holder must be replaced.
- ✓ Blade and spindle bolts and nuts should be checked daily.

**Maintenance****Routine Maintenance Checklist**

Interval	Item	Check	Lube	Change	Comments
Daily Or 10 Hours	Pivot Points		•		
	Grease Fittings		•		
	Blades	•			Change If Damaged (In Pairs)
	Blade Bolts (Blade To Disk)	•			Change With Damaged Blades ( In Pairs)
	Blade Holder Nut	•			Change With Damaged Blades (In Pairs)
	Spindle Bolts (Spindle To Deck)	•			
	Main Frame And Deck Bolts	•			
	Rubber Shielding	•			Change If Damaged
Weekly Or 50 Hours	Hydraulic Return Filter			•	Change After 1st 50 Hours, Then Every 500 Hours
	Hydraulic Fittings	•			
Monthly Or 150 Hours	Tank Breather	•			
	Hydraulic Fluid Level	•			
Seasonal Or 500 Hours	In Tank And Return Hydraulic Filters			•	



## Troubleshooting

### Troubleshooting Guide

#### Hydraulic System, Blade System, Pump, Motor, Fluid Lines

Problem	Possible Cause	Solution / Correction
Cylinder Will Not Operate	Tractor Remotes not engaged	Engaged Remote
	Tractor Remote engaged In Reverse	Engage Remotes Opposite Way Or Switch Hydraulic Lines In Tractor Remotes.
Head Drifts Back When In Operation	Improper Relief Valve Setting	Adjust Relief Valves To Tractor Specifications
	Cylinder Leakage	Repair / Replace Cylinders
Leaking Motor	Motor Seal Blown	Repair / Replace Seal And Check Filter For Blockage (Repair / Replace Filter)
Blades Lose Speed In Mowing	Improper Relief Valve Setting	Check Relief Valve Setting (Call Dealer)
		Repair / Replace Relief Valve
Pump Whines	Worn Or Damaged Pump	Repair / Replace Pump
	Improper Oil In System	Replace Oil Requires Hardee Oil Part NO 23333 Or Comparable Oil With Proper Viscosity
	Pressure Setting On Relief Valve Too Low	Check Relief Valve Setting (Call Dealer)
Motor Whines	Worn Or Damaged Motor	Repair / Replace Motor
	Improper Oil In System	Replace Oil Requires Hardee Oil Part NO 23333 Or Comparable Oil With Proper Viscosity
	Pressure Setting On Relief Valve Too Low	Check Relief Valve Setting (Call Dealer)
Unit Vibrates Severely	Broken Blade	Replace Blades, Blade Bolts And Nuts (Refer to page 12)
	Blade Holder Loose	Repair / Replace Blade Holder (Refer to page 12)
	Loose Output Shaft	Repair / Replace Shaft's Bearings In Cutter Head Housing
Mower Head Grinds And Roars When Operating	Worn Bearings Or Improper Lubrication In Mower Hydraulic Motor Housing	Repair / Replace Components (Bearing, Seals And Housing) As Required

**Troubleshooting**

**Troubleshooting Guide, continued**

**Hydraulic System, Blade System, Pump, Motor, Fluid Lines**

Problem	Possible Cause	Solution / Correction
Individual Cylinders Leak Down	Blown Or Worn Cylinder Packing	Repair / Replace Cylinder
Blades Won't Start-Up		Repair / Replace Hydraulic Lines
	Oil Flow Restricted	Replace In-Tank Filter

Specifications

Model MITI MIKE -35

- A. 137"
- B. 75"
- C. 89"
- D. 51"
- E. 38"
- F. 170°
- G. 70"
- H. 110"

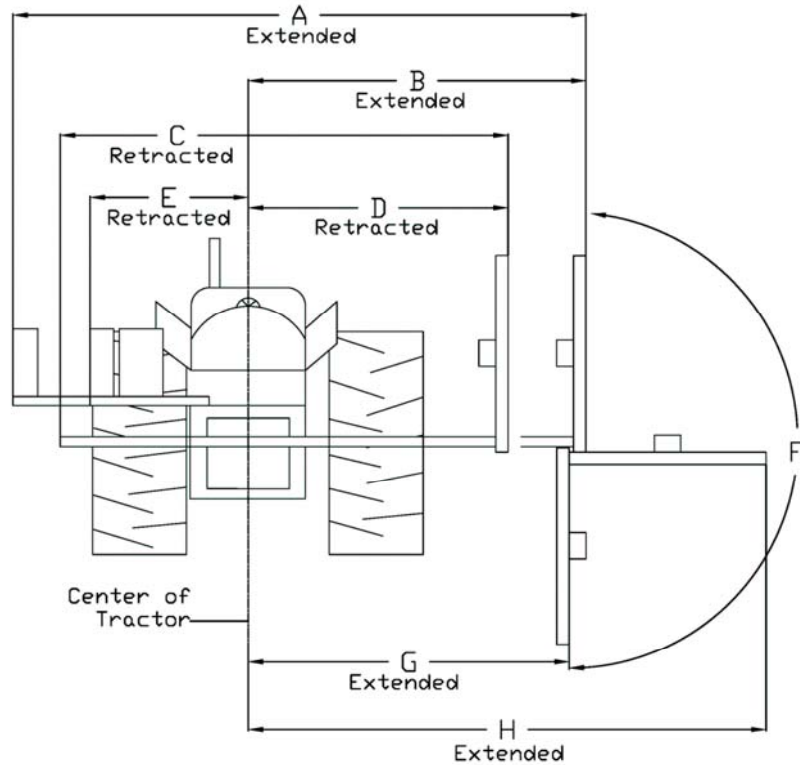

## Specifications

### Summary of Specifications

#### MODEL

Miti Mike - 35			
Approximate Weight (lbs.)	740 - Ready To Mow		
Blade Tip Speed (ft/min)	540 PTO – 16,000 ft/min		
Blades	Oval blade carrier		
Mowing Capacity / Suggested Usage	Brush up to 1/2" dia.		
Mowing Width	35"		
Driveline	Category 1		
Driveline Protection	Hydraulic Relief Valve		
Hitch	Standard Hitch, Category 1		
Motor	Hydraulic Gear Motor		
Reach (center of tractor to outside of cutter)	9'2" max.		
Width for trailering and road travel	7'5" min.		
PTO Operating Speed	540 RPM		
Pump	Hydraulic Gear Pump		
Oval Blade Holder	Standard		
Rubber Shielding	Standard – Front & Rear		
Tractor HP/ Weight Required	Min. 22 hp. / 1900 lbs.		
Hydraulic Oil System Capacity	12 Gallons		
For best mowing results, run tractor PTO speed between 500-540 RPM			
Lateral mowing positions 85 degrees up or down			
Counter weight is manually adjustable in, and out			

Item	Part Number	Qty.	Description	50	16451	1	HOSE ASSY 3/4" - VALVE TO VALVE -NOT SHOWN
1	10002	10	Hex Bolt, 1/4"-20 X 1" Gr.5 Plated				
2	10031	2	Hex Bolt 3/8 x 1 gr.5 plated	51	16452	1	HOSE ASSEMBLY 3/4"-TANK TO MOTOR-NOT SHOWN
3	10032	6	Hex Bolt 3/8 x 1-1/2 gr.5 plated	52	16455	1	HOSE ASSY 1/2"-CONTROL TO CYL - NOT SHOWN
4	10071	1	Hex Bolt 1/2 x 1 gr.5 plated	53	16456	1	HOSE ASSY 1/2"-CONTROL TO CYL - NOT SHOWN
5	10121	1	Hex Bolt (3/4" X 8" Gr. 5 Plated)	54	16457	1	HOSE ASSEMBLY 3/4"-VALVE TO MOTOR-NOT SHOWN
6	10153	8	Lock Nut, 1/4" Plated	55	16460	1	QD BUSHING - MITI MIKE
7	10168	1	3/4"-10 Locknut (Gr.5 Plated)	56	16463	1	HYDRAULIC PUMP - MITI MIKE
8	10175	6	3/8"-16 Locknut (Gr.5 Plated)	57	16464	1	MOTOR - MITI MIKE
9	10176	4	1/2" Locknut (Gr.5 Plated)	58	16467	1	FILTER KIT - MITI MIKE
10	10182	2	Lockwasher 3/8 plated	59	16562	1	FAN FOR HYDRAULIC OIL TANK - MITI MIKE
11	10184	4	Lockwasher 1/2 plated	60	16564	1	3/8"X126"HOSE ASSY NOT SHOWN
12	10200	14	1/4" Plated Flatwasher	61	16565	1	4-M-NPT X 6-M-JIC 45 DEG ELBOW
13	10202	14	3/8" Flatwasher (Plated)	62	16566	1	4-M-NPT X 6-M-JIC (STRAIGHT)
14	10206	4	Flatwasher 3/4 plated	63	16569	1	WIRING HARNESS - NOT SHOWN
15	10207	8	Flatwasher, 1" plated	64	16576	2	Decal, MITI MIKE - 35
16	10252	5	Cotter Pin 3/16" X 2" Plated	65	16652	1	PTO ADAPTER
17	10307	2	Category I Hitch Pin	66	16752	1	2-1/2" Cylinder (20-1/4" to 30-1/4")
18	10339	2	Pop Rivet	67	25724	2	WELDMENT, Cylinder Pin
19	10346	2	3 pt. Snap Pin (Lynch Pin)	68	26881	1	LINK - CYLINDER - MITI MIKE
20	10375	1	Relief Valve	69	26882	1	WELDMENT - DECK - MITI MIKE
21	10390	2	Clip Pin (1/8 x 2)	70	26890	1	WELDMENT- DECK LINK
22	10393	2	Universal Clip Pin	71	26895	1	WELDMENT - EXTENSION ARM - MITI MIKE
23	10420	2	Clip Pin (3/16 x 3 3/4)	72	26903	1	WELDMENT - PIN - MITI MIKE
24	10501	1	FLOW EZY BREATHER	73	26906	1	WELDMENT HITCH FRAME - MITI MIKE
25	10502	1	Reservoir Cover	74	26920	1	WELDMENT - WEIGHT BOX - MITI MIKE
26	10841	3	QUICK LINK, 3/16' SCREW	75	26925	1	WELDMENT - OIL TANK -MITI MIKE
27	11001	1	Decal, Danger - Rotating Blades	76	26931	1	Assembly, Blade Holder, Miti Mike
28	11005	1	Decal, Warning - Thrown Objects	77	26932	2	WELDMENT- STAND - MITI MIKE
29	11032	2	Small Hardee Logo Decal	78	26940	2	FLAT - BELTING - MITI MIKE
30	11727	1	Serial Number Plate	79	26941	2	BELTING - FRONT & BACK - MITI MIKE
31	11872	2	6-M-NPT X 6-M-JIC 90 Deg. Elbow	80	26943	2	PIN - DECK/WEIGHT BOX
32	13675	1	3/4" NPT X 3" METAL NIPPLE	81	26944	2	WELDMENT - PIN - MITI MIKE
33	13717	1	1" NPT THREADED COUPLING	82	26948	1	WELDMENT - Flat, Pump Stabilizer
34	13899	2	#6 JIC CAP	83	26954	1	PLATE - FAN MOUNT/SHROUD
35	13974	1	16-M-JIC X 16-M-NPT 90 Deg. Elbow	84	26957	1	CHAIN - SHIPPING, Miti Mike
36	13975	1	12-M-ORB X 12-M-JIC 90 Deg. Elbow				
37	13976	2	12-M-JIC X 12-M-NPT 90 Deg. Elbow				
38	13978	2	12-M-JIC X 12-M-NPT STRAIGHT				
39	15256	2	Hex Bolt (1/4" X 2-3/8" Gr. 5 Plated)				
40	15845	1	Hydraulic Decal Kit				
41	15852	2	Red Reflector Decal				
42	15853	2	Yellow Reflector Decal				
43	15860	4	U-Nut, 1/4"-20				
44	16011	1	Fitting,12 R6X-S Swivel Nut Run Tee				
45	16012	2	Fitting,12 F50X-S Straight Thread Connector				
46	16191	1	16-M-JIC X 16-M-NPT 90 Deg. Elbow				
47	16335	1	Hour Meter - not for resale				
48	16449	1	HOSE ASSEMBLY 1" - TANK TO PUMP - NOT SHOWN				
49	16450	1	HOSE ASSEMBLY 3/4"-PUMP TO VALVE-NOT SHOWN				

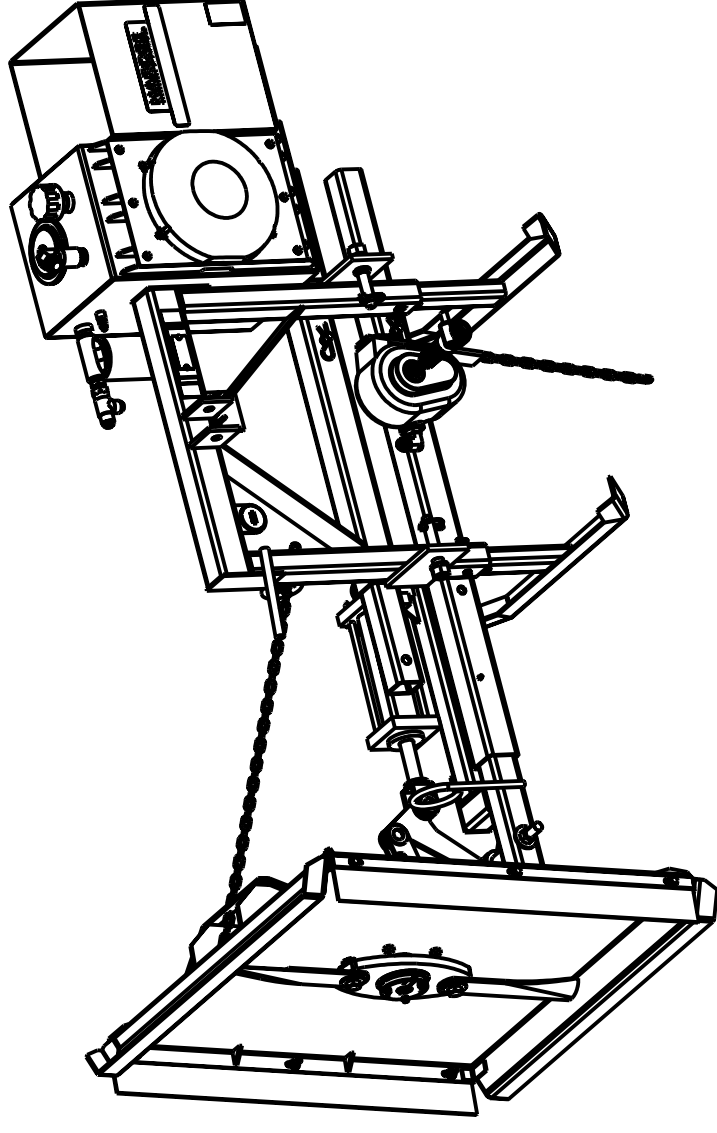

DWG. NO.	26880			REV.	C
REV	CHANGE	BY	DATE	ECN	
IR	INITIAL RELEASE	C.K.N.	3/1/12	---	
A	Add 16335 - Hour Meter	C.K.N.	4/24/12	1483	
B	ADD 16652 PTO ADAPTER	C.K.N.	9/30/13	1549	
C	Manufacture Cylinder Change	T.B.B.	5/25/16	1655	

MODELED BY	C.K.N.	3/1/12	HARDEE BY	
DRAWN BY	C.K.N.	3/1/12	EVH MFG. CO.	
			LORIS S.C.	
MATERIAL	R.M.N.		DESCRIPTION	SHEET 1 of 2
	N/A		MITI MIKE	
Manufactured By:	EVH Mfg. Co., LLC		DO NOT SCALE	DWG. NO.
			B	26880
			DWG. NO.	

All Dimensions in Inches Unless Otherwise Specified

Dimensions in [ ] are in Millimeters

Tolerance Unless Otherwise Specified

Fractional Dimensions ± 1/16" Angular Dimensions ± 1°

Decimal Dim. to Limits Shown All Holes to be +0 -1/32"

DWG. NO.

26880

REV.

C

REV	CHANGE	BY	DATE	ECN
IR	INITIAL RELEASE	C.K.N.	3/1/12	---
A	Add 16335 - Hour Meter	C.K.N.	4/24/12	1483
B	ADD 16652 PTO ADAPTER	C.K.N.	9/30/13	1549
C	Manufacture Cylinder Change	T.B.B.	5/25/16	1655

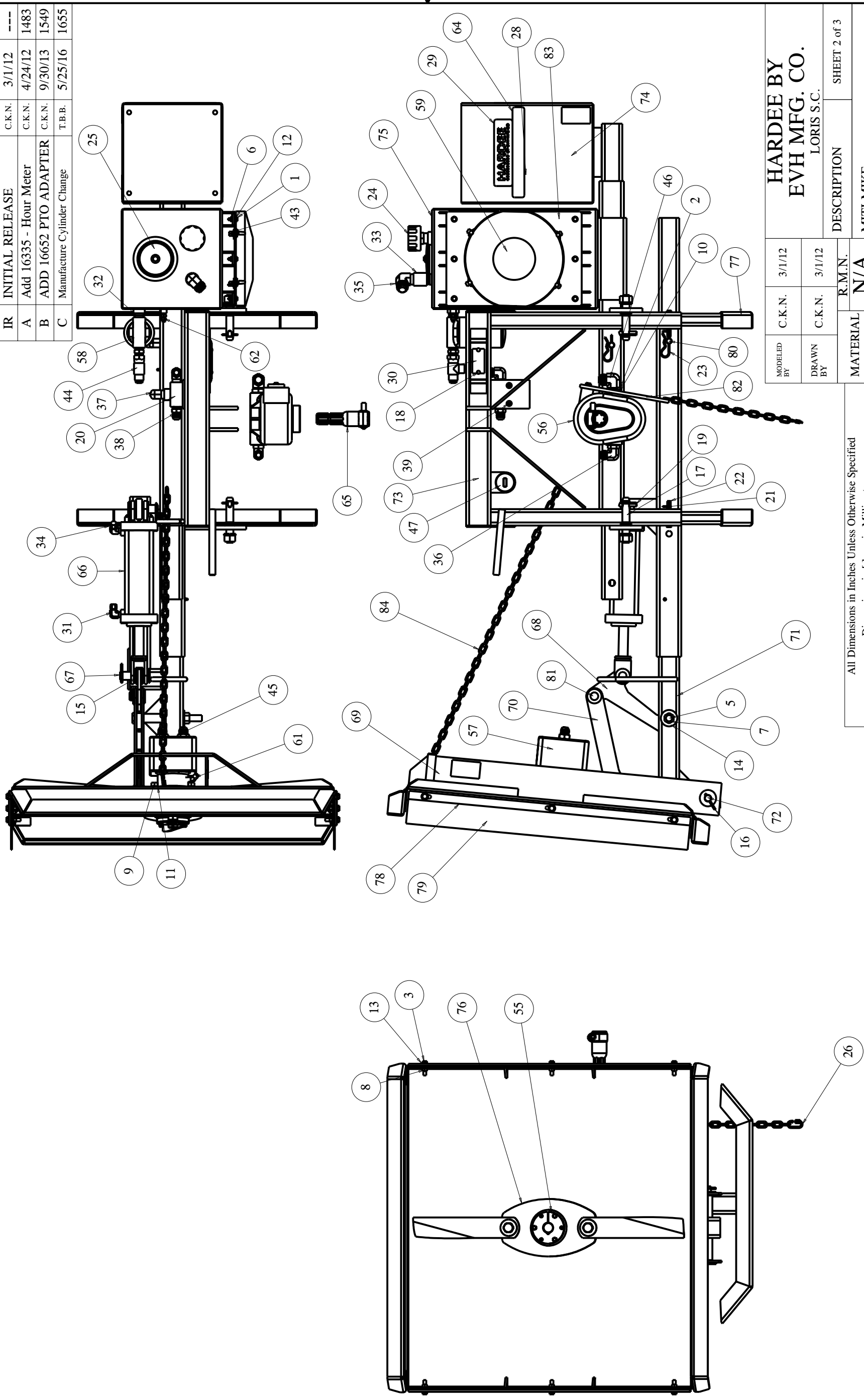

MODELED BY	C.K.N.	3/1/12	<b>HARDEE BY</b> <b>EVH MFG. CO.</b> LORIS S.C.
DRAWN BY	C.K.N.	3/1/12	
MATERIAL	R.M.N.	N/A	DESCRIPTION
Manufactured By: EVH Mfg. Co., LLC			MITI MIKE
All Dimensions in Inches Unless Otherwise Specified Dimensions in [ ] are in Millimeters Tolerance Unless Otherwise Specified <b>Fractional Dimensions ± 1/16"</b> Angular Dimensions ± 1° Decimal Dim. to Limits Shown			SHEET 2 of 3
DO NOT SCALE			DWG. NO. <b>26880</b>

# HYDRAULIC SCHEMATIC FOR MITI MIKE -35

DWG. NO. <b>26880</b>		REV. <b>C</b>	
IR	INITIAL RELEASE	C.K.N.	06/09/10
A	REMOVE VALVES FOR CYL.	C.K.N.	1/9/12 1465
B	ADD 16652 PTO ADAPTER	C.K.N.	9/30/13 1549
C	Manufacture Cylinder Change	T.B.B.	5/25/16 1655

FAN FOR HYDRAULIC TANK  
16562

WIRING HARNESS FOR FAN  
16569

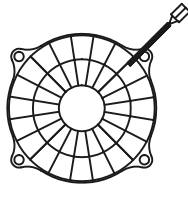

HYDRAULIC PUMP  
16463

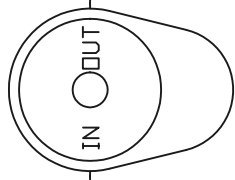

RELIEF VALVE  
10375



TRACTOR REMOTES  
16456

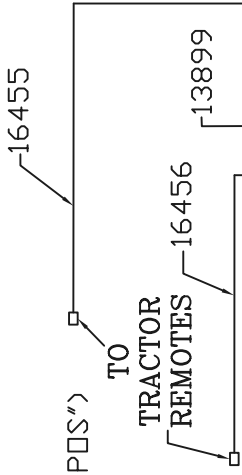

HYDRAULIC CYLINDER  
16752



OIL TANK

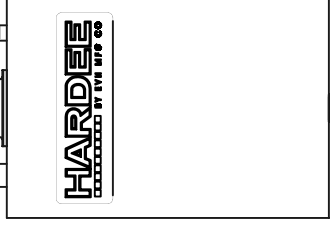

HYDRAULIC MOTOR  
16464

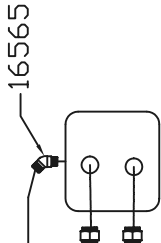

NOTE: 16543  
MOTOR  
SEAL  
KIT

16467 (REPLACEMENT FILTER 16469)

All Dimensions in Inches Unless Otherwise Specified  
Dimensions in [ ] are in Millimeters  
Tolerances Unless Otherwise Specified  
Fractional Dimensions ±1/16"  
Angular Dimensions ±1°  
Decimal Dim. to Limits Shown All holes to be ±0.005

DRAWN BY	C.K.N.	06/09/10	APPLICATION MITI MIKE	OLD PART #
CHECKED BY	---	---	DESCRIPTION MITI MIKE HYDRAULIC ASSEMBLY	DO NOT SCALE
MATERIAL	R.M.N.	N/A	MANUFACTURED BY: EVH MANUFACTURING CO	DWG. NO. <b>26880</b>
			SCALE	DWG. SIZE/SHT 1 OF 1

HARDEE BY  
EVH MFG. CO.  
LORIS S.C.

DWG. NO.	26931	REV.	IR
REV. CHANGE	BY	DATE	ECN
IR INITIAL RELEASE	C.K.H.	8/16/10	- - -

16460 - NOT PART OF 26931 - REPLACEMENT PARTS ONLY

Item	Part Number	Qty.	Description
1	16460	1	OD BUSHING - MITI MIKE
2	16474	2	Slotted Hex Nut - Zinc-Plated Grade 5 Steel
3	16475	4	FLAT WASHER - 3/4" - USS THRU-HARD
4	16476	2	COIL SPRING PIN - 1/8" HEAVY DUTY - 1-1/4" LONG
5	16477	2	BLADE, Miti Mike
6	16570	1	BOLT KIT, Replacement for Blade Holder Bushing
7	26929	1	WELDMENT - BLADE HOLDER
8	26952	2	BOLT - BLADE - MITI MIKE
9	26965	1	SHAFT KEY, MITI MIKE MOTOR

16570 - NOT PART OF 26931 - REPLACEMENT PARTS ONLY

26965 - NOT PART OF 26931 - REPLACEMENT PARTS ONLY

**BLADE INSTALLATION:**  
 1. INSTALL BLADE AS SHOWN BELOW.  
 2. HAND TIGHTEN NUT ON BOLT UNTIL LOOSE PLAY IS OUT.  
 3. LOOSEN NUT UNTIL THE SLOT IN NUT ALIGNS WITH THROUGH HOLE IN BOLT.  
 IF BLADE SWINGS FREELY, INSTALL COIL PIN AND SKIP STEP 4.  
 4. IF BLADE IS STILL TIGHT, LOOSEN NUT ONE SLOT AT A TIME AND RETRY.  
 WHEN BLADE SWINGS FREELY, INSTALL COIL PIN.

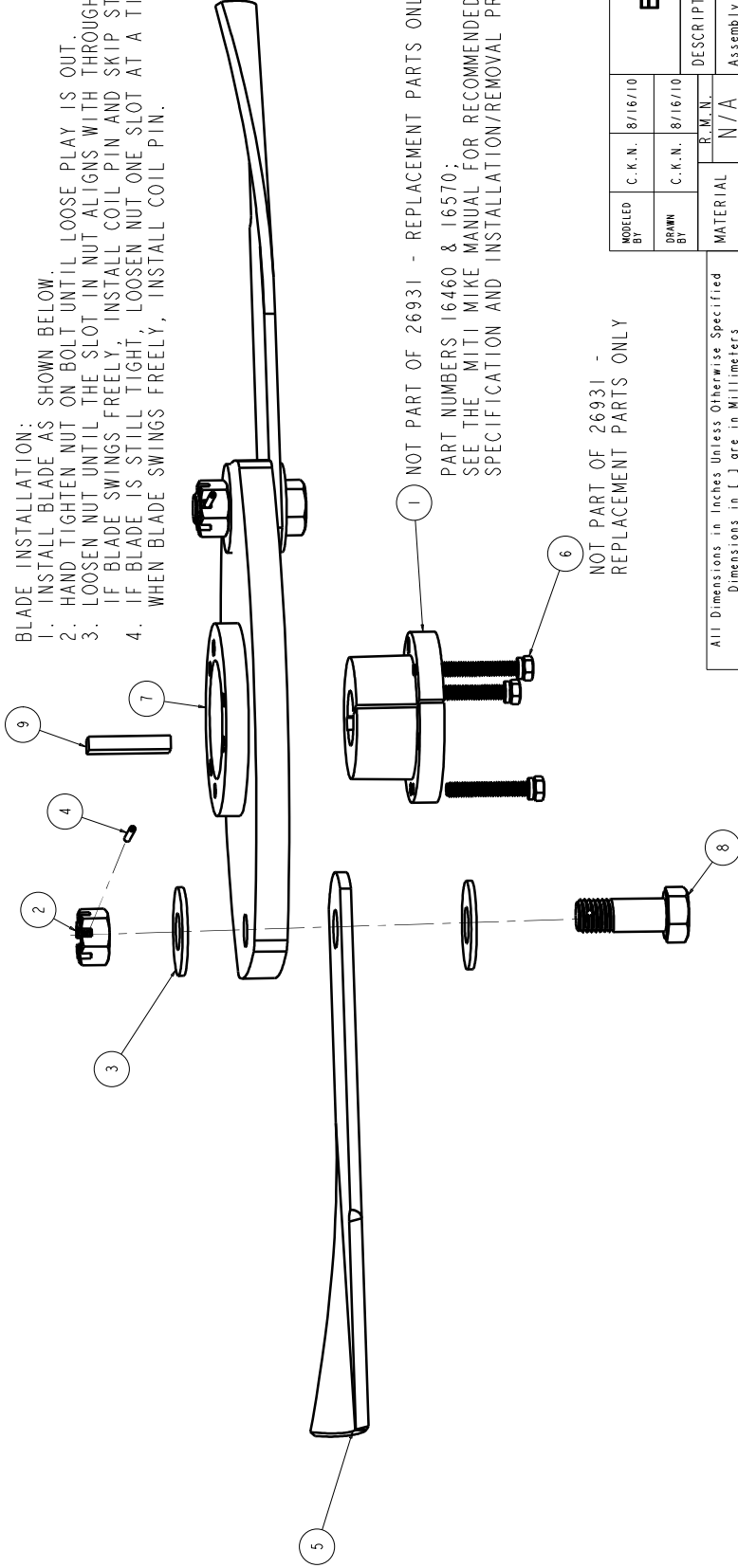

1 NOT PART OF 26931 - REPLACEMENT PARTS ONLY

PART NUMBERS 16460 & 16570;  
 SEE THE MITI MIKE MANUAL FOR RECOMMENDED TORQUE  
 SPECIFICATION AND INSTALLATION/REMOVAL PROCEDURES

NOT PART OF 26931 -  
 REPLACEMENT PARTS ONLY

MODELLED BY	C.K.N.	8/16/10	DESCRIPTION	SHEET 1 of 1
DRAWN BY	C.K.N.	8/16/10		
MATERIAL	R.M.N.	N/A	Assembly, Blade Holder, Miti Mike	
Manufactured By:			DO NOT SCALE	DWG. NO.
Evh Mfg. Co., LLC			SCALE	26931

All Dimensions in Inches Unless Otherwise Specified  
 Dimensions in J are in Millimeters  
 Tolerance Unless Otherwise Specified  
 Fractional Dimensions ± 1/16" Angular Dimensions ±  
 Decimal Dim. to Limits Shown All Holes to be 10 -1/32"

**HARDEE BY**  
**EVH MFG. CO.**  
 LORIS S.C.

## QD Bushing/Sheaves Installation

QD bushing sizes JA through N can be assembled in either of the two positions shown below. Sizes P through S should be assembled in position one. *Position One* is the conventional or standard mounting. *Position Two* (Reverse Mounting) may be necessary in some cases, such as mounting small sheaves with blind holes (not drilled through).

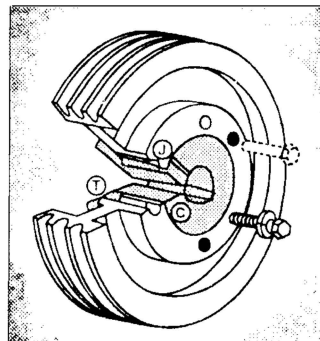

**Position 1**

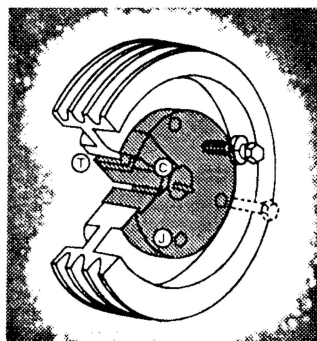

**Position 2**

Bushing Size	Cap Screw Size-Thread	Foot Pounds Wrench Torque*
SK	5/16-18	10

\*For Normal Applications. For Severe (Rock-crusher type) applications these values can be increased by a maximum of 50%  
**Caution: Excessive cap-screw torque can cause sheave and/or bushing breakage. The use of lubricants can cause sheave breakage.**

Therefore,

**DO NOT USE LUBRICANTS IN THIS INSTALLATION!**

### INSTALLATION:

1. Make sure the tapered-cone surface of the bushing and the mating bore of the sheave are free of all foreign substances, such as dirt, excess paint accumulations, metal chips, lubricants, etc.
2. For position one or two (whichever applies), line up the unthreaded holes (C) with the threaded holes (t) and insert cap screws with lock washers engaging only two or three threads. (\*a)
3. With key in shaft keyway, slide the loosely-assembled unit onto shaft and position for good belt alignment. (\*b, \*c) **Use no lubricants or anti-seize compound on threads or tapered surfaces.**
4. Carefully tighten the capscrews alternately and progressively until the tapers are seated (at approximately half the recommended torque).
5. Check alignment and sheave runout (wobble) and correct as necessary.
6. Continue careful alternate and progressive tightening of the cap screws to the recommended torque values shown in the table. **Maximum torque should be achieved on each individual bolt only two times in the consecutive tightening.**

**Note:** When properly mounted, there will be a gap between the bushing flange and sheave after the screws are tightened.

**Caution: Use of Lubricants and or excessive screw torque can cause breakage**

7. Tighten the set screw, when available, to hold the key securely during operation.

### REMOVAL

1. Loosen and remove all mounting cap screws.
2. Insert cap screws in all threaded jack screw holes (J).
3. Start with the screws furthest from the bushing saw slot and tighten all jack screws alternately and progressively. Keep turning the screws in small equal amounts until the tapered surfaces disengage.

(\*a) When mounting a sheave on M through W size bushing, position the threaded jack-apart hole (J) as far from the bushing saw as possible to reduce the possibility of bushing breakage.

(\*b) When installing large or heavy parts in *Position One*, it may be easier to mount the key and bushing on the shaft first. Then place the sheave on the bushing and align the holes.

(\*c) **Caution:** When mounting on a vertical shaft, provisions must be made, which will positively prevent the sheave and/or bushing from dropping during installation.



## Bolt Torque

### Checking Bolt Torque

The tables shown below give correct torque values for various bolts and capscrews. Tighten all bolts to the torque specified in the chart unless otherwise noted. Check tightness of bolts periodically, using bolt torque chart as a guide. Replace hardware with the same strength bolt. Torque figures indicated are valid for non-greased or non-oiled threads and heads unless otherwise specified. Therefore, do not grease or oil bolts or cap screws unless otherwise specified in this manual. When using locking elements, increase torque values by 5%.

**NOTE:** Bolt Torques shown are maximum allowable values for ultimate safe working strength or external load-carrying capacity. The bolt torque are not applicable in cases where bolts are used as a pin-like device, holding together two or more movable objects and keeping them from spreading apart. – “Clamping Torque” Being dependent upon the application of the bolt. -

*Torque value for bolts and cap screws are identified by their head markings.  
See Page 2*

### Torque Specifications for Coarse Threads

Diameter “A”	Bolt Torque		Coarse Thread			
	SAE-2		SAE-5		SAE-8	
	LB-FT	N.m	LB-FT	N.m	LB-FT	N.m
1/4" - 20	6	8	9	12	12	17
5/16" - 18	10	13	19	25	27	36
3/8" - 16	20	27	33	45	45	63
7/16" - 14	30	41	53	72	75	100
1/2" - 13	45	61	80	110	115	155
9/16" - 12	70	95	115	155	165	220
5/8" - 11	95	128	160	215	220	305
3/4" - 10	165	225	290	390	400	540
7/8" - 9	170	230	420	570	650	880
1" - 8	225	345	630	850	970	1320
1 1/8" - 7	354	478	794	1072	1287	1737
1 1/4" - 7	500	675	1120	1512	1875	2531
1 3/8" - 6	655	884	1470	1985	2382	3216
1 1/2" - 6	870	1175	1950	2632	3161	4267

See next page for Torque Specifications for Fine Threads and Head Markings

**Torque Specifications for Fine Threads**

Diameter "A"	Bolt Torque					
	SAE-2		SAE-5		SAE-8	
	LB-FT	N.m	LB-FT	N.m	LB-FT	N.m
1/4" - 28	6	8	10	14	14	19
5/16" - 24	12	16	19	26	27	36
3/8" - 24	22	31	35	47	49	66
7/16" - 20	36	49	55	74	78	105
1/2" - 20	55	74	85	115	120	162
9/16" - 18	80	108	122	165	172	232
5/8" - 18	110	148	170	230	240	324
3/4" - 16	200	270	297	400	420	567
7/8" - 14	180	243	474	640	668	402
1" - 12	274	370	705	952	995	1343
1" - 14	280	378	721	973	1019	1376
1 1/8" - 12	397	536	890	1201	1444	1950
1 1/4" - 12	553	747	1241	1675	2012	2716
1 3/8" - 12	746	1007	1672	2257	2712	3661
1 1/2" - 12	979	1322	2194	2962	3557	4802

**Head Markings**

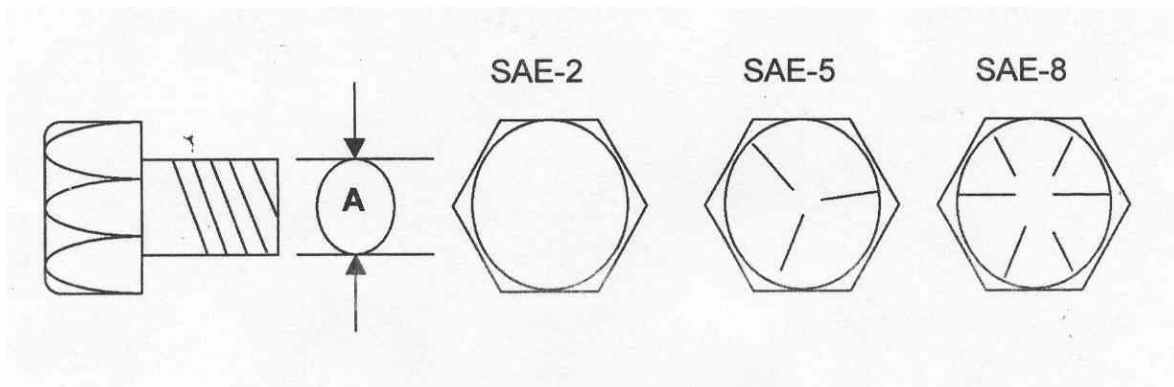

## Hardee by EVH Manufacturing Co., LLC Hydraulic Mower Limited Warranty

Hardee by EVH Manufacturing Co., LLC warrants its **Hydraulic Mowers** for one year or **350 hours** (whichever comes first) to the **original** non-commercial, non-governmental, or non-municipal purchaser. For the **original** commercial, industrial, or municipal purchaser, the goods are warranted for 90 days or **350 hours** (whichever comes first) to be free from defects in material or workmanship.

This limited warranty does not apply to any part of the goods which have been subjected to improper or abnormal use, negligence, alteration, modification, accident, or damage due to lack of maintenance, wrong oil or lubricants, or which has served its normal life.

Hardee by EVH Manufacturing Co., LLC **Hydraulic Mowers** include the following units: Miti Mike-35, Tiger SS, DB4048, DB4060, EV1442, MR1442, LR40142, LR40148, LR50148, LR50160, HR2360, and CM2160 Mowers.

The Warranty Card **must** be filled out and returned within **30 days** of purchase. **No** warranty will be allowed without a properly completed and returned warranty card.

“Our obligation under this warranty shall be limited to repair or replacement of any part or parts of this implement, which, in our judgement, shows evidence of such defect, and provided further, that said parts shall be removed and returned by the owner at the owner’s expense to Hardee by EVH Manufacturing Co., LLC, Loris, SC, through an authorized dealer, transportation prepaid, free and clear of liens or encumbrances.”

### **This warranty shall not include normal wear items.**

Changes or alterations to the implement made without the **written** authorization of the manufacturer will render this warranty void. **Tampering with or removing the factory installed hour meter will void this warranty.**

This warranty does not obligate this company to bear any labor costs in replacement of defective parts.

Hardee by EVH Manufacturing Co., LLC reserves the right to make changes or improvements in its equipment at any time, with the express understanding that such changes or improvements do not impose any obligation of the company to install such changes or improvements on implements previously manufactured.

Hardee by EVH Manufacturing Co., LLC Hydraulic Mowers are designed as **Agricultural** machines. They are designed to be used intermittently in **farm** use, **not** constantly as in “Commercial” use. Our machines are designed with brains instead of brawn, to fit the maximum number of tractors. They are not designed nor priced as Commercial machines that operate 8 hours a day / 5 days a week.

The CM2160 is the exception to the above statement, having been designed as a Commercial machine.

**IMPLIED WARRANTIES:** You may have some implied warranties. For example, you may have an implied warranty of merchantability (that the hydraulic mower is reasonably fit for the general purpose for which it was sold) or an implied warranty of fitness for a particular purpose (that the hydraulic mower is suitable for your special purposes). Special purposes must be specifically disclosed to Hardee by EVH Manufacturing Co., LLC, and not merely to the dealer before your purchase. Hardee by EVH Manufacturing Co., LLC itself must approve, in writing, that the special purpose is warrantable.

**These implied warranties do not apply at all if you use your hydraulic mower for business or commercial use.**

## **NOTES:**

## **NOTES:**



HARDEE BY EVH MANUFACTURING COMPANY, LLC  
4895 RED BLUFF ROAD LORIS, SC 29569  
PHONE: 843-756-2555  
[www.hardeebyevh.com](http://www.hardeebyevh.com) [evhmfg@hardeebyevh.com](mailto:evhmfg@hardeebyevh.com)