

ITEM	PART #	QTY	DESCRIPTION
1	10098	5	HEX BOLT 5/8" X 5-1/2"
2	10099	4	Hex Bolt (5/8" X 5-1/2" GR. 5 Plated)
3	10117	1	Hex Bolt (3/4" X 5" GR. 5 Plated)
4	10118	1	Hex Bolt (3/4" X 5-1/2" GR. 5 Plated)
5	10166	40	Lock Nut (5/8" Plated, REV.)
6	10167	2	Hex Nut (3/4" Plated)
7	10172	4	Hex Head Locknut (1-1/8" Plated)
8	10206	8	Flat Washer, SAE (3/4" Plated)
9	10339	2	Rivet, 1/8" X 3/8"
10	10466	2	Hitch Pin, CAT 2
11	10901	2	Bumper Cap (Front)
12	10906	8	Bearing Spacer
13	10907	4	Nut Washer
14	10910	24	Disc Blade 22" Cutout
15	10918	8	Half Spool 6"
16	10919	12	Spool 9"
17	10922	4	Gang Bolt 49"
18	11032	3	Small Hardee Logo Decal
19	11064	2	Model # Decal For D-21-24-22
20	11636	1	Landscape & Disc Harrow Safety Decal
21	11727	1	Hardee MFG. Serial Number Plate
22	11850	1	Website Decal
23	15451	32	Carriage Bolt (5/8" X 5-1/2" GR.5 Plated)
24	15852	2	Rear Decal-Red Reflector
25	15853	2	Front Decal-Yellow Reflector
26	60029	1	Gang Pin Rear Weldment
27	60037	4	Nut Lock
28	60038	1	Gang Pin Front Weldment
29	60081	2	Bumper Cap, Slotted, (Rear)
30	60160	2	Gang Beam Weldment (64")
31	60162	2	Gang Beam Weldment (52")
32	60164	4	Gang Tie Plate Weld
33	60166	6	Clamp Cap For Double Hanger
34	60167	2	Single Clamp Cap
35	60190	1	D21 Main Frame Weldment
36	60191	1	A-Frame Weldment
37	60197	1	A- Frame Brace Weldment
38	60277	2	Axle Hanger
39	60278	6	Double Axle Hanger
40	10111	2	HEX BOLT 3/4" X 2"

DWG. NO.		60180		REV.		G	
REV	CHANGE	BY	DATE	ECN			
E	MRP B.O.M. CHANGES	T.R.M.	3/23/04	0958			
F	REDREW DRAWING	J.S.S.	2/20/09	1231			
G	REASSEMBLED 60180	J.S.S.	5/7/09	1314			

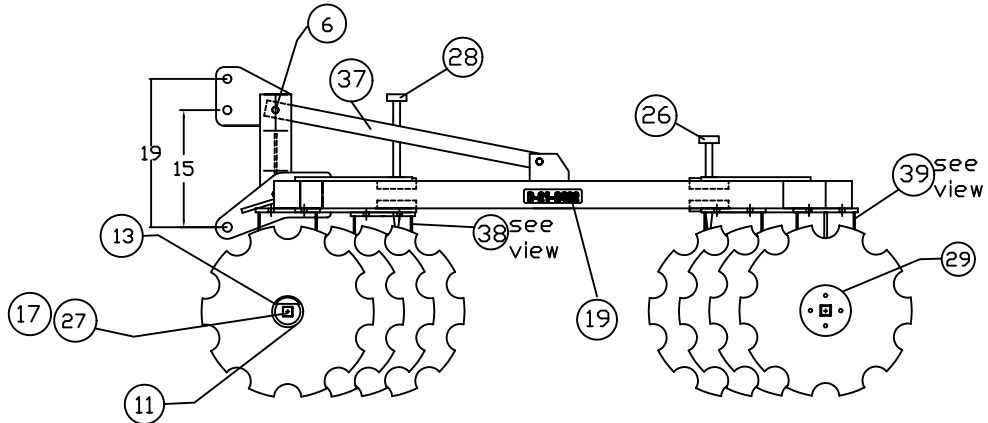
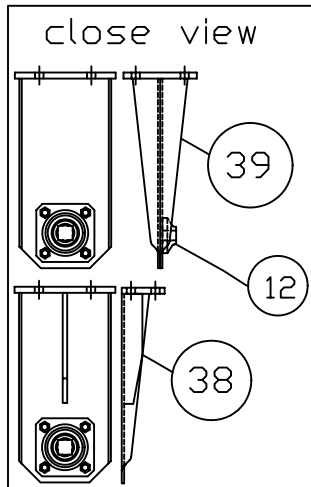
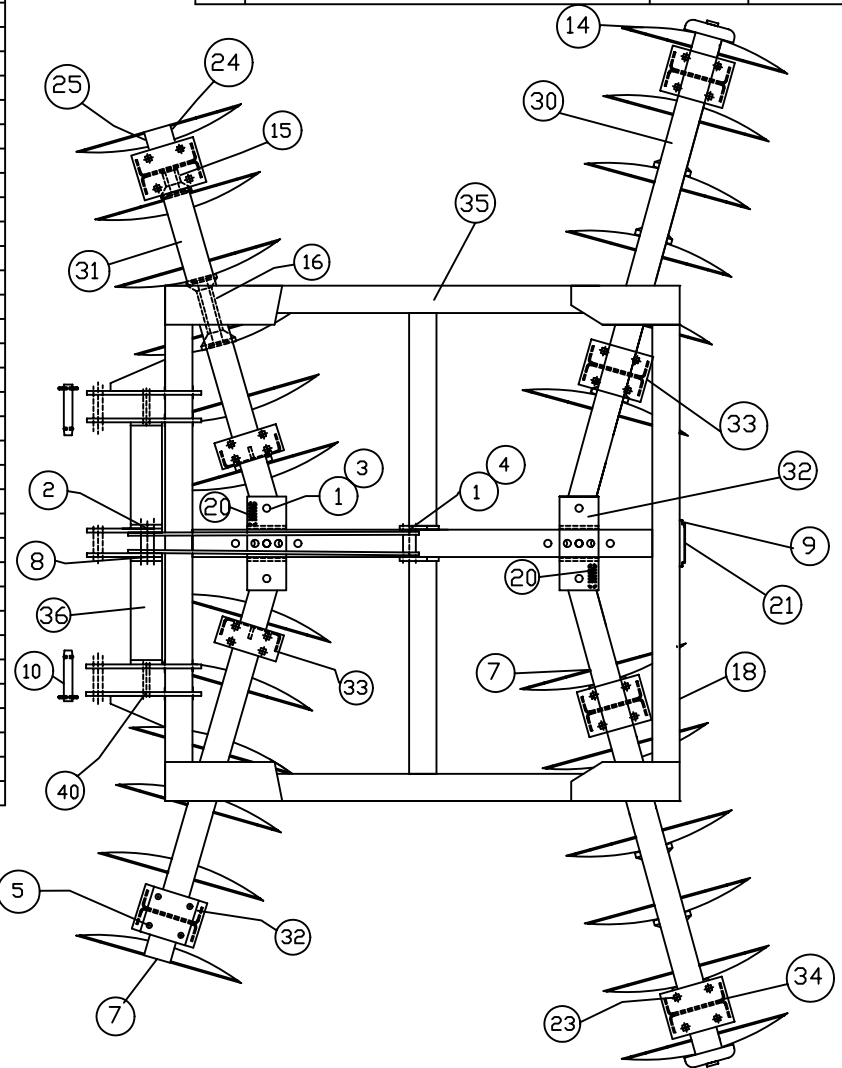

All Dimensions in Inches Unless Otherwise Specified
 Dimensions in [] are in Millimeters

Tolerances Unless Otherwise Specified
 Fractional Dimensions ±1/16" Angular Dimensions ±1°
 Decimal Dim. to Limits Shown All holes to be $\begin{matrix} +0 \\ -1/32 \end{matrix}$

DRAWN BY	J.S.S.	2/20/09	EVH MFG. CO., LLC LORIS S.C.	
CHECKED BY				
MATERIAL	R.M.N.	---	APPLICATION	OLD PART #
MANUFACTURED BY: EVH MFG. CO., LLC			DISC HARROW	----
			DESCRIPTION D-21-2422 ASSEMBLY	
DO NOT SCALE	A	DWG. NO.	60180	
		SHT 1 OF 1		