

ITEM NO.	PART NUMBER	QTY REQD.	NOMENCLATURE OR DESCRIPTION
1	10002	2	1/4" x 1" HEX BOLT
2	10015	4	5/16" X 1/2" HEX BOLT
3	10035	1	3/8" X 3" HEX BOLT
4	10091	2	5/8" X 1-1/2" HEX BOLT
5	10097	4	5/8" X 4-1/2" HEX BOLT
6	10111	4	3/4" X 2" HEX BOLT
7	10112	4	3/4" X 2-1/2" HEX BOLT
8	10117	1	3/4" X 5" HEX BOLT
9	10118	1	3/4" X 5-1/2" HEX BOLT
10	10154	2	5/16" LOCK NUT
11	10166	6	5/8" LOCK NUT
12	10168	12	3/4" LOCK NUT
13	10173	1	CASTLE NUT (1")
14	10175	1	3/8" LOCK NUT
15	10176	6	1/2" LOCK NUT
16	10181	4	5/16" LOCK WASHER
17	10182	1	3/8" LOCK WASHER
18	10186	4	3/4" LOCK WASHER
19	10200	2	1/4" FLAT WASHER
20	10201	4	5/16" FLAT WASHER
21	10243	1	5/32" X 2" COTTER PIN
22	10260	6	1/2" X 1-1/2" PLOW BOLT
23	10322	1	1/4" GREASE FITTING
24	10330	2	4"X8"X15" SOLID TIRE & RIM
25	10335	2.15	RED PAINT (GAL.)
26	10336	.38	GEAR OIL (GAL.)
27	10339	2	RIVET 1/8" X 3/8"
28	10345	1	GEARBOX - 125 HP - 1:1
29	10464	2	CAT 1 & 2 HITCH PIN
30	10475	1	SHAFT CONE
31	10646	.15	GREASE (LBS.)

DWG. NO.			REV.	
20550			G	
REV	CHANGE	BY	DATE	ECN
F	CHANGE SERIAL # PLATE	T.R.M.	6/2/00	0792
G	CHANGE TO FLAT STRUT	T.R.M.	1/21/03	0937

32	11001	1	DANGER DECAL
33	11002	2	KEEP CLEAR DECAL
34	11003	1	CAUTION DECAL
35	11004	1	CAUTION DECAL
36	11005	1	WARNING DECAL
37	11006	1	SAFETY DECAL
38	11015	2	MODEL # DECAL, 1184
39	11131	2	HARDEE DECAL (5" X 16")
40	11567	1	DRIVESHAFT
41	11727	1	SERIAL NUMBER PLATE
42	11850	1	WEBSITE DECAL
43	15852	2	RED REFLECTOR
44	15854	1	MANUAL HOLDER
45	15860	2	U-NUT 1/4"-20
46	20031	1	ACCESS COVER
47	20187	2	TAILWHEEL FORK & ARM
48	20195	2	TAILWHEEL HUB
49	20441	1	SPACER
50	20440	2	SLIDE
51	20301	1	BLADE HOLDER W/BLADES
52	20520	1	DECK WELDMENT, 1184W
53	20343	1	"A" FRAME - LEFT SIDE
54	20344	1	"A" FRAME - RIGHT SIDE
55	20491	2	FLAT STRUT
56	20426	1	CAT 2 FLOATING LINKAGE
57	20439	2	"A" FRAME BRACE
58	20901	1	FRONT BELTING KIT
59	20817	1	REAR BELTING KIT
60	20356	2	SPECIAL BOLT FOR CAT. PINS

All Dimensions in Inches Unless Otherwise Specified
Dimensions in [] are in Millimeters

Tolerances Unless Otherwise Specified
Fractional Dimensions ±1/16" Angular Dimensions ±1"
Decimal Dim. to Limits Shown All holes to be $\begin{matrix} +0 \\ -1/32 \end{matrix}$

DRAWN BY	M.J.T	3/3/99	EVH MANUFACTURING CO LORIS S.C.	
CHECKED BY				
MATERIAL		R.M.N.	APPLICATION 1184W	OLD PART # ----
MANUFACTURED BY: EVH MANUFACTURING CO			DESCRIPTION ASSEMBLY FOR 1184W	
DO NOT SCALE	A	DWG. NO.	20550	
DWG SIZE		SHT 1 OF 3		

DWG. NO.

20550

REV.

G

REV	CHANGE	BY	DATE	ECN
C	CHANGE DRIVESHAFT	M.J.T	5/10/99	0607
D	ACCESS COVER REPLACEMENT	T.O.B.	11/5/99	0697
E	CHANGE PART NUMBER	T.R.M.	12/3/99	0688
F	CHANGE SERIAL # PLATE	T.R.M.	6/2/00	0792
G	CHANGE TO FLAT STRUT	T.R.M.	1/21/03	0937

TOP VIEW

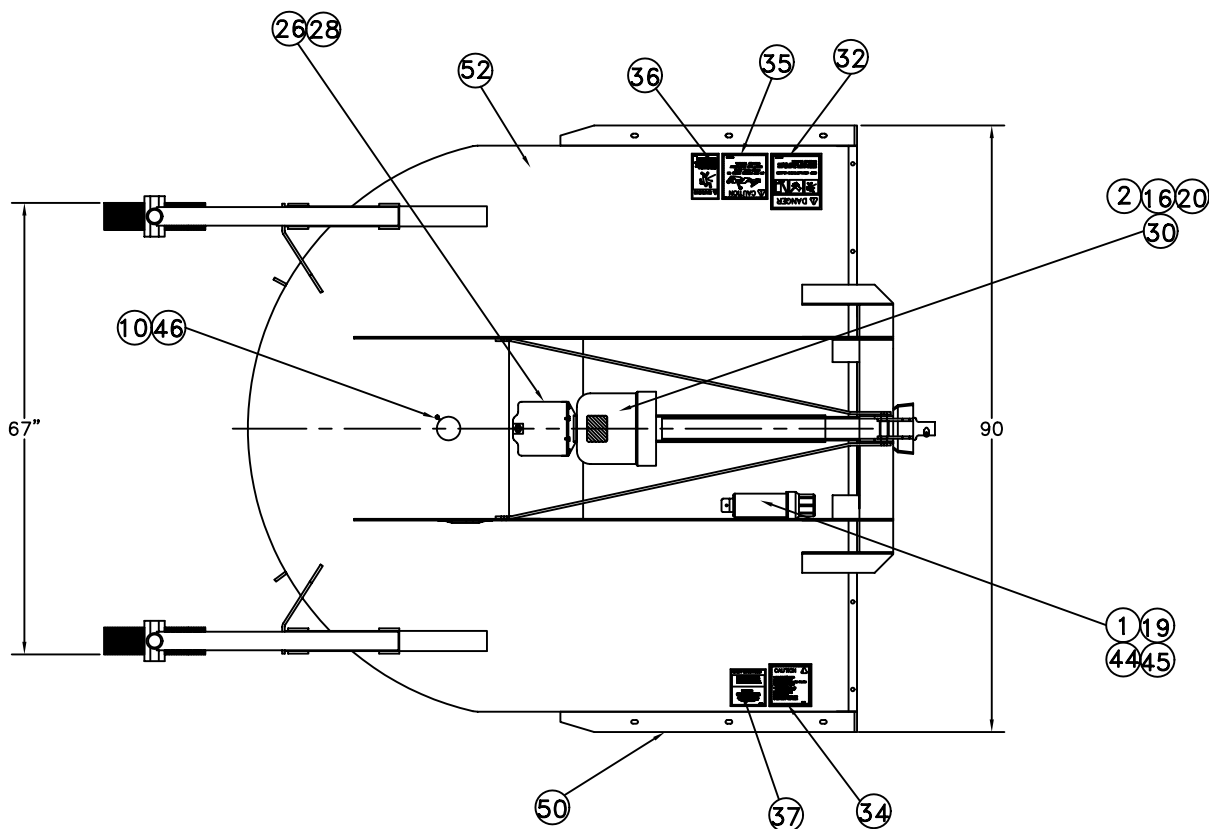

R.H. SIDE VIEW

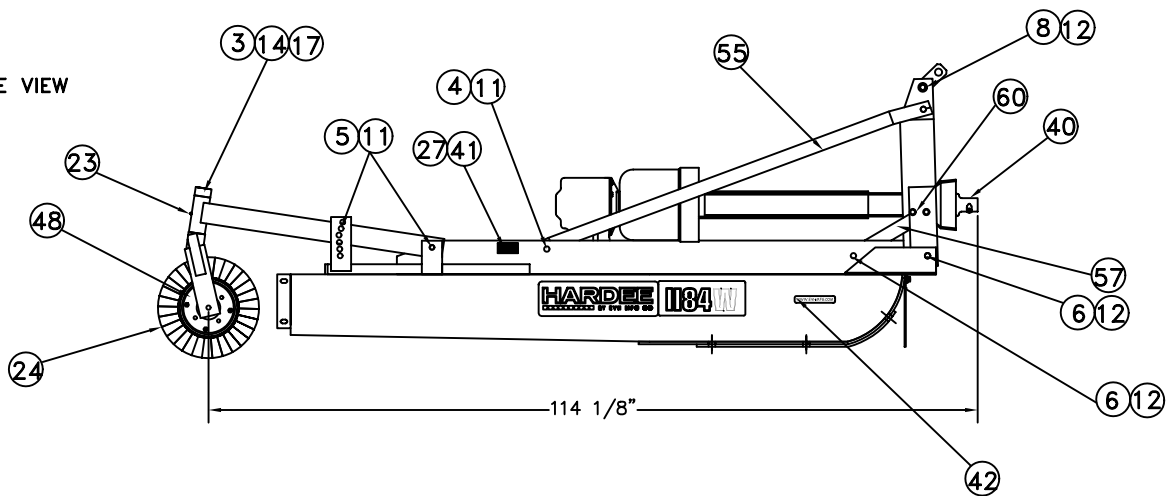

DRAWN BY	M.J.T	3/3/99	EVH MANUFACTURING CO LORIS S.C.	
CHECKED BY				
MATERIAL	R.M.N.		APPLICATION	OLD PART #
MANUFACTURED BY: EVH MANUFACTURING CO			1184W	----
			DESCRIPTION	
			ASSEMBLY FOR 1184W	
DO NOT SCALE	A	DWG. NO.	20550	
DWG SIZE		SHT 2 OF 3		

All Dimensions in Inches Unless Otherwise Specified
Dimensions in [] are in Millimeters

Tolerances Unless Otherwise Specified
Fractional Dimensions $\pm 1/16"$ Angular Dimensions $\pm 1^\circ$
Decimal Dim. to Limits Shown All holes to be $^{+0}_{-1/32}$

DWG. NO.

20550

REV.

G

REV	CHANGE	BY	DATE	ECN
C	DRIVESHAFT CHANGE	M.J.T	5/10/99	0607
D	ACCESS COVER REPLACEMENT	T.O.B.	11/5/99	0697
E	CHANGE PART NUMBER	T.R.M.	12/3/99	0688
F	CHANGE SERIAL # PLATE	T.R.M.	6/2/00	0792
G	CHANGE TO FLAT STRUT	T.R.M.	1/21/03	0937

NOTES:

- DRAWING FOR INFORMATION ONLY.
PARTS REMOVED FOR CLARITY, GRAPHICS NOT TO SCALE.

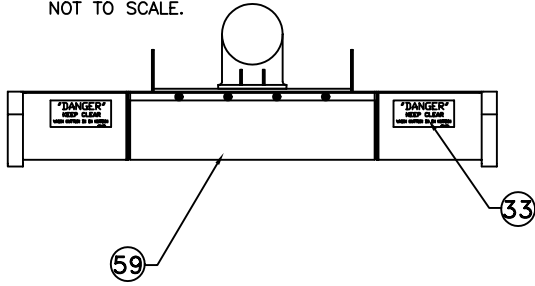

L.H. SIDE VIEW

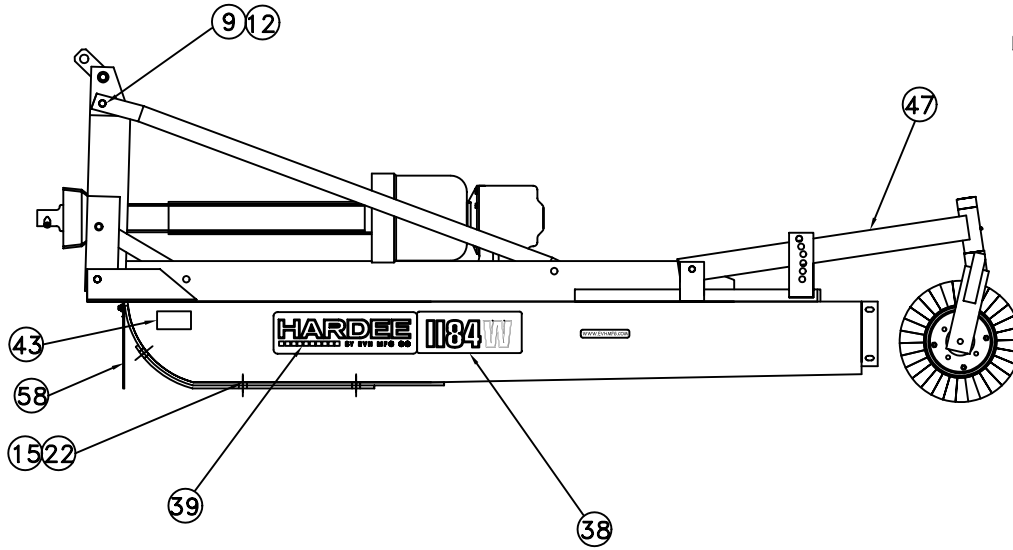

FRONT VIEW

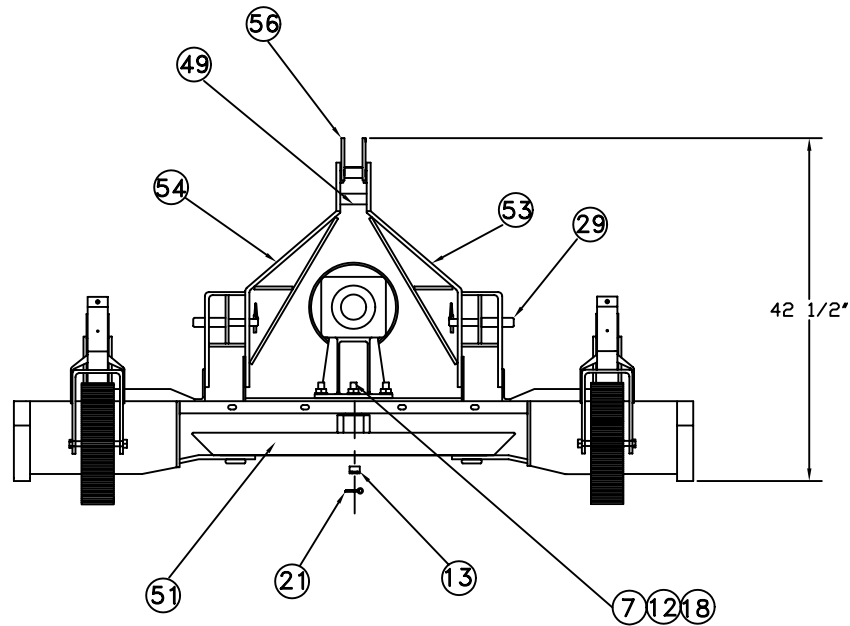

DRAWN BY	M.J.T	3/3/99	EVH MANUFACTURING CO LORIS S.C.	
CHECKED BY				
MATERIAL	R.M.N.		APPLICATION	OLD PART #
MANUFACTURED BY: EVH MANUFACTURING CO			1184W	----
			DESCRIPTION	
DO NOT SCALE	A	DWG. NO.	20550	
	DWG SIZE	SHT 3 OF 3		

All Dimensions in Inches Unless Otherwise Specified
Dimensions in [] are in Millimeters

Tolerances Unless Otherwise Specified
Fractional Dimensions $\pm 1/16"$ Angular Dimensions $\pm 1^\circ$
Decimal Dim. to Limits Shown All holes to be $+0$
 $-1/32$

ITEM NO.	PART NUMBER	QTY REQD.	NOMENCLATURE OR DESCRIPTION
1	20543	1	BLADE HOLDER WELDMENT
2	10421	2	UP LIFT BLADE
3	10313	2	BLADE BOLT GR.8
4	10312	2	BLADE BOLT LOCKWASHER GR.8
5	10311	2	BLADE BOLT NUT GR.8

DWG. NO.			REV.	
20301			B	
REV	CHANGE	BY	DATE	ECN
IR	INITIAL RELEASE	M.J.T	11/4/97	----
A	CREATE VIEWS	M.J.T	6/11/98	0381
B	REMOVE BOLT FROM Q-HUB	T.O.B.	11/24/99	0670

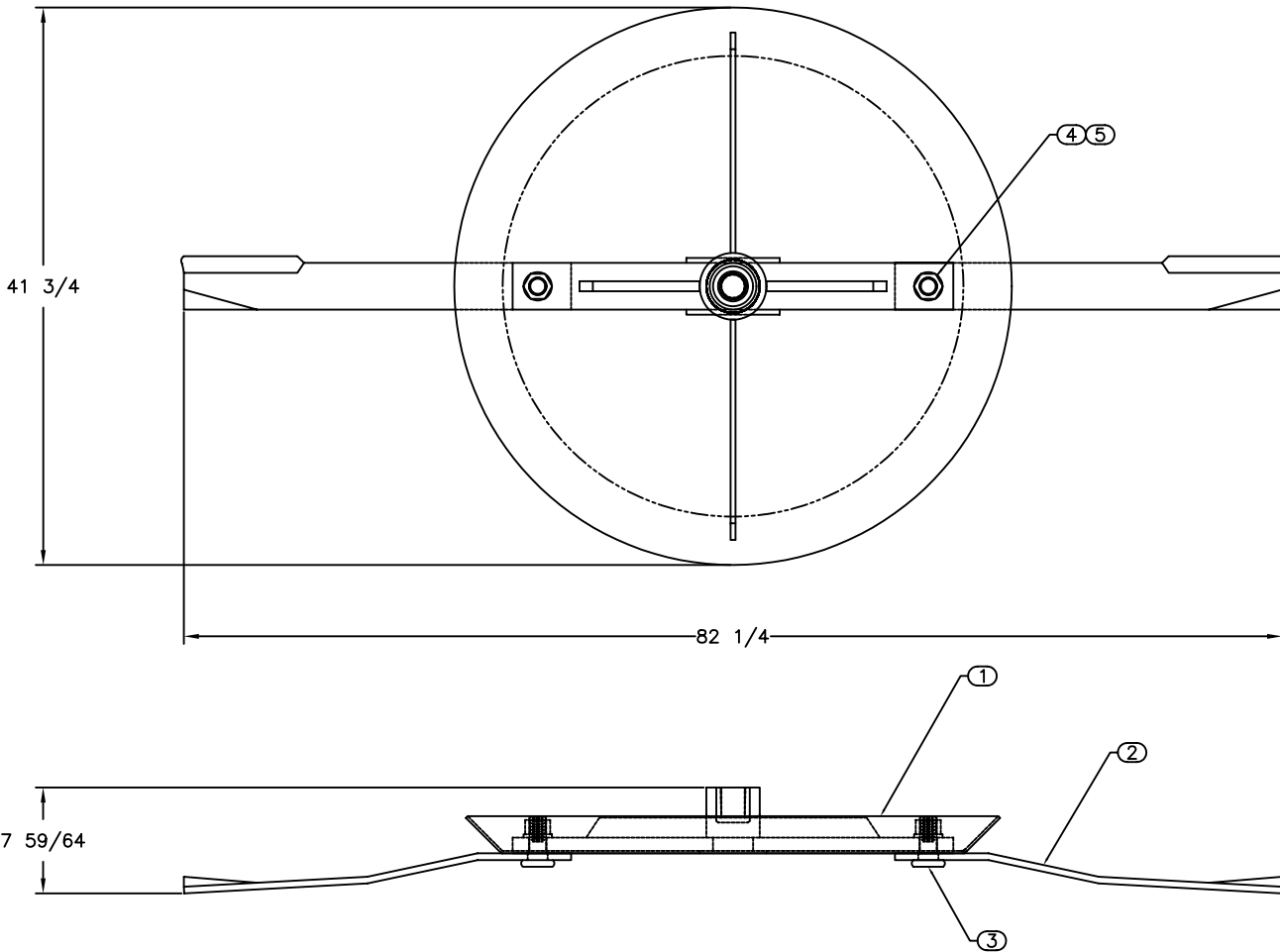

DRAWN BY	M.J.T	6/11/98	HARDEE BY EVH MFG CO LORIS S.C.	
CHECKED BY				
MATERIAL	R.M.N.		APPLICATION	OLD PART #
MANUFACTURED BY HARDEE WILLIAMS			DESCRIPTION BLADE HOLDER SUBASSEMBLY	
DO NOT SCALE	A	DWG. NO.	20301	
	DWG SIZE			

All Dimensions in Inches Unless Otherwise Specified
Dimensions in [] are in Millimeters

Tolerances Unless Otherwise Specified
Fractional Dimensions $\pm 1/16"$ Angular Dimensions $\pm 1^\circ$
Decimal Dim. to Limits Shown All holes to be $^{+0}_{-1/32}$

10345 Gearbox

(125H.P. Gearbox 1: 1 Ratio)

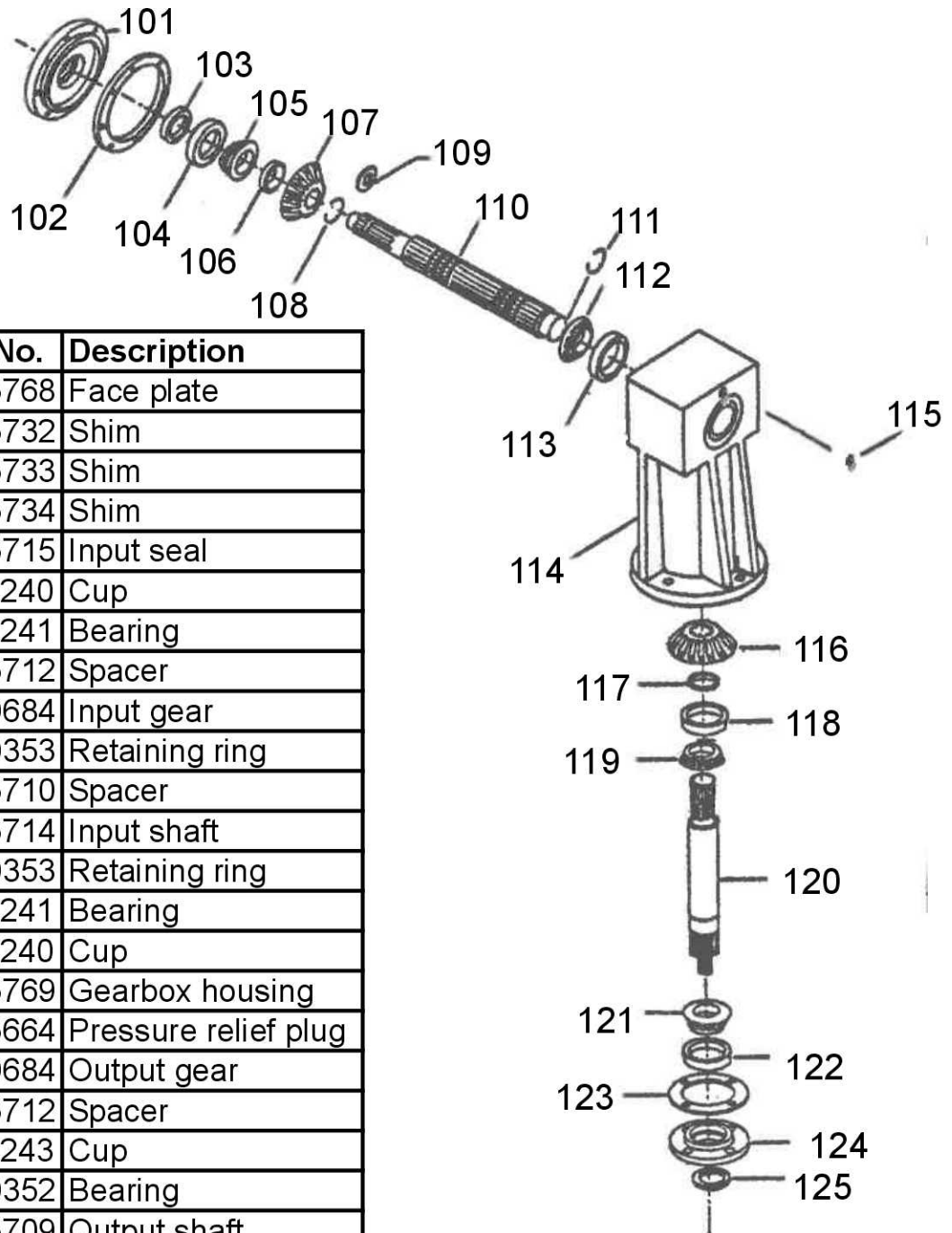

Key #	Part No.	Description
101	15768	Face plate
102	15732	Shim
	15733	Shim
	15734	Shim
103	15715	Input seal
104	11240	Cup
105	11241	Bearing
106	15712	Spacer
107	10684	Input gear
108	10353	Retaining ring
109	15710	Spacer
110	15714	Input shaft
111	10353	Retaining ring
112	11241	Bearing
113	11240	Cup
114	15769	Gearbox housing
115	15664	Pressure relief plug
116	10684	Output gear
117	15712	Spacer
118	11243	Cup
119	10352	Bearing
120	15709	Output shaft
121	10352	Bearing
122	11242	Cup
123	15706	Bottom cover
124	15705	Shim
125	10354	Output seal

11567 Driveshaft

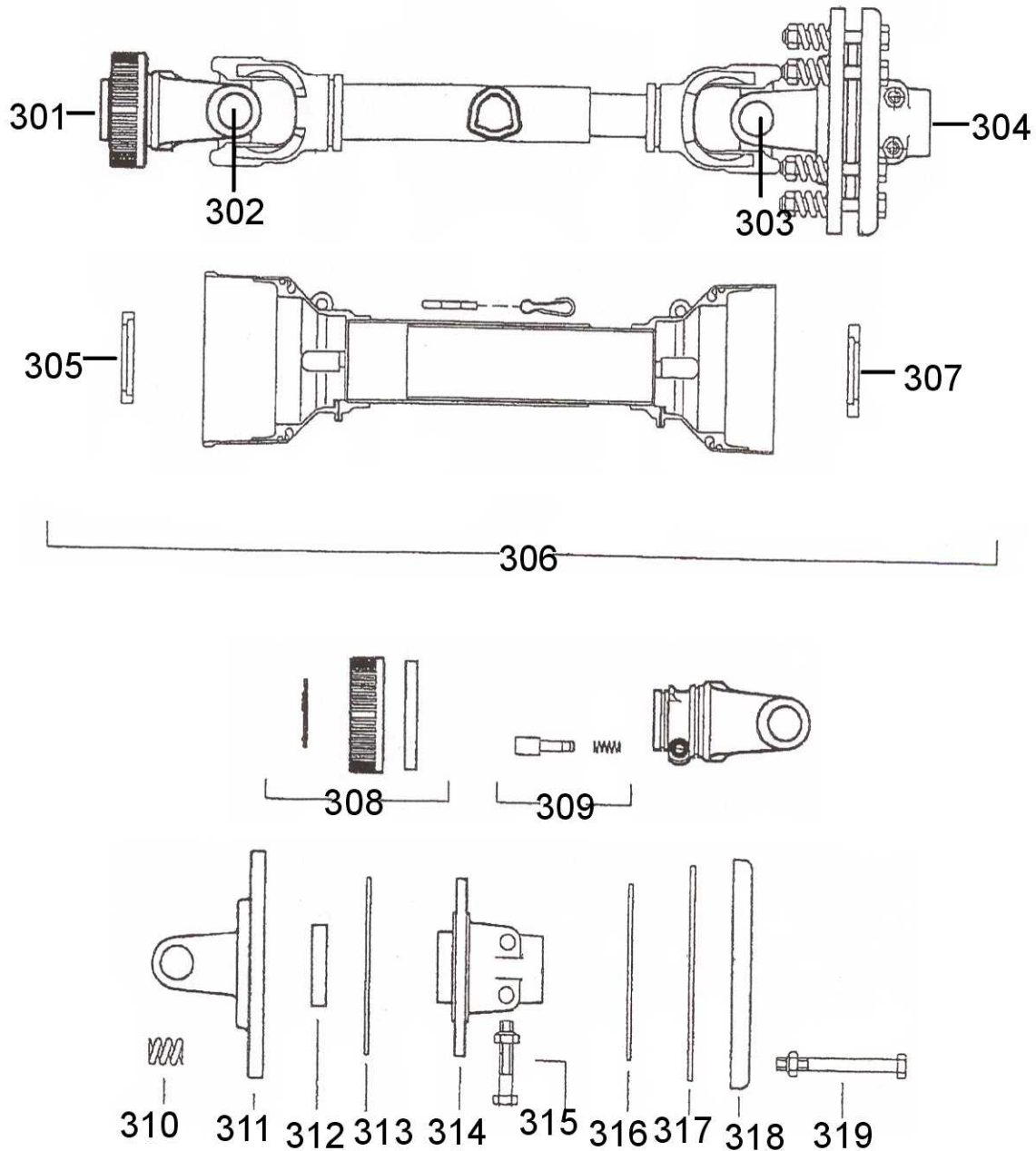

Key #	Part No.	Description	Key #	Part No.	Description
301	11440	Yoke, Tractor end	311	15806	Flange yoke
302	15559	Cross kit	312	15562	Bushing
303	15559	Cross kit	313	11204	Clutch facing
304	11444	Clutch, complete	314	15802	Center hub
305	15800	Shield bearing	315	15803	Clutch bolt
306	11749	Shield kit complete	316	11204	Clutch facing
307	15801	Shield bearing	317	15563	Inner plate
308	15786	Twist collar kit	318	15799	Pressure plate
309	15579	Push pin complete	319	15794	Clutch bolt
310	15561	Spring			