

DWG. NO.

20485

REV.

J

REV	CHANGE	BY	DATE	ECN
G	CHANGE PART NUMBER	T.R.M.	12/6/99	0688
H	CHANGE SERIAL # PLATE	T.R.M.	6/1/00	0792
I	DRIVESHAFT WAS 11567	R.T.N.	4/01/05	1058
J	B.O.M CHANGES	B.C	6/28/07	1162

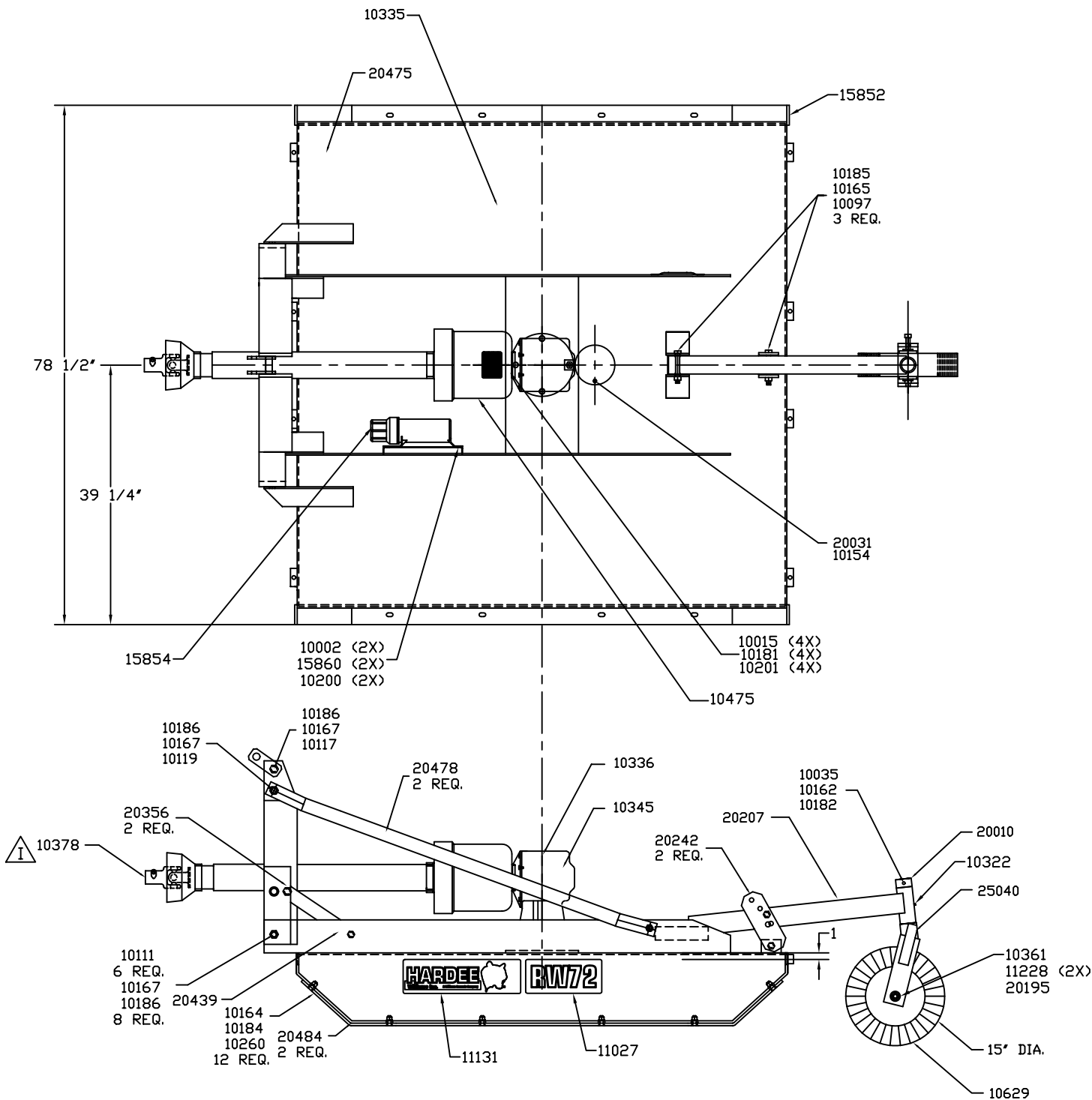

DRAWN BY	M.J.T.	4/6/99
CHECKED BY		
MATERIAL	R.M.N.	
MANUFACTURED BY: EVH MFG. CO., LLC		

EVH
Manufacturing Co
 LORIS S.C.

APPLICATION: RW72
 OLD PART #: ---
 DESCRIPTION ASSEMBLY DRAWING FOR RW72

DO NOT SCALE
 DWG SIZE: A
 DWG. NO.: 20485
 SHT 1 OF 2

All Dimensions in Inches Unless Otherwise Specified
 Dimensions in [] are in Millimeters

Tolerances Unless Otherwise Specified
 Fractional Dimensions ±1/16"
 Decimal Dim. to Limits Shown
 Angular Dimensions ±1°
 All holes to be +0/-1/32

DWG. NO.

20485

REV.

J

REV	CHANGE	BY	DATE	ECN
G	CHANGE PART NUMBER	T.R.M.	12/6/99	0688
H	CHANGE SERIAL # PLATE	T.R.M.	6/1/00	0792
I	DRIVESHAFT WAS 11567	R.T.N.	4/01/05	1058
J	B.O.M CHANGES	B.C	6/28/07	1162

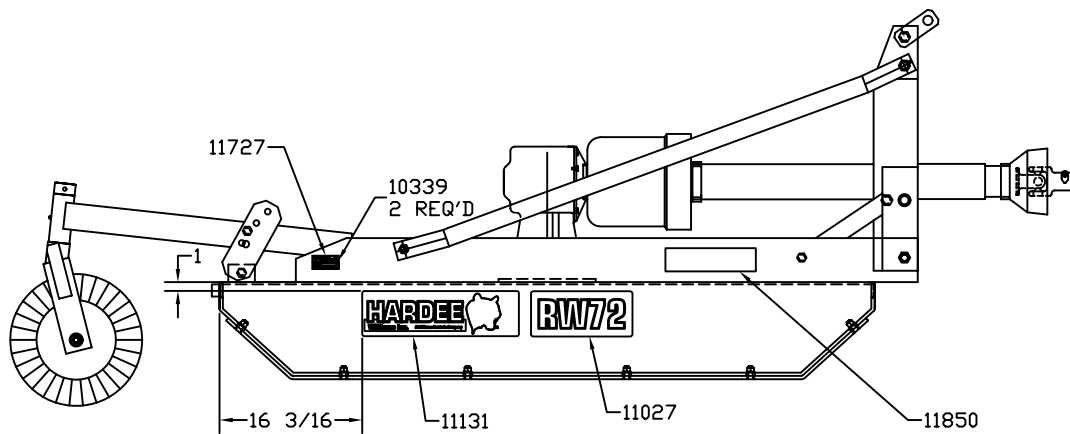

R.H. SIDE VIEW

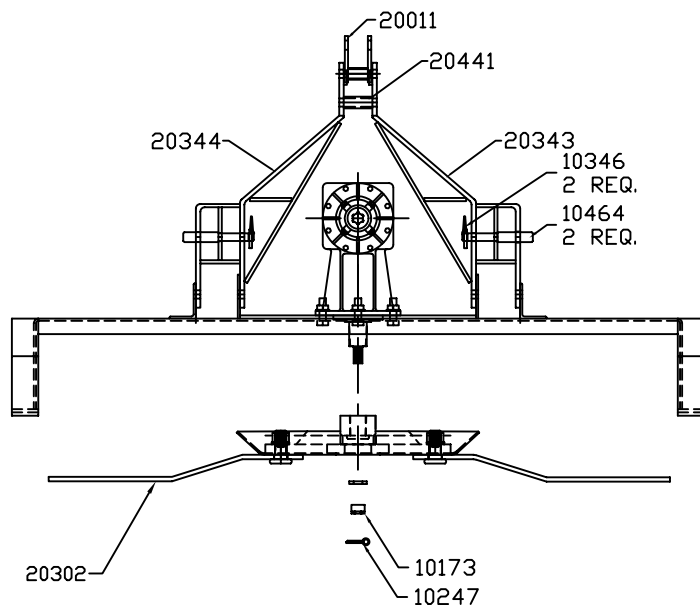

DRAWN BY	M.J.T.	4/6/99
CHECKED BY		
MATERIAL	R.M.N.	
MANUFACTURED BY: EVH MFG. CO., LLC		

EVH
Manufacturing Co
LORIS S.C.

APPLICATION RW72	OLD PART # ----
DESCRIPTION ASSEMBLY DRAWING FOR RW72	

DO NOT SCALE	A	DWG. NO.
DWG SIZE	SHT 2 OF 2	20485

All Dimensions in Inches Unless Otherwise Specified
 Dimensions in [] are in Millimeters

Tolerances Unless Otherwise Specified
 Fractional Dimensions $\pm 1/16"$
 Decimal Dim. to Limits Shown
 Angular Dimensions $\pm 1^\circ$
 All holes to be $\begin{matrix} +0 \\ -1/32 \end{matrix}$

ITEM NO.	PART NUMBER	QTY REQD.	NOMENCLATURE OR DESCRIPTION
1	20460	1	BLADE HOLDER WELDMENT
2	10377	2	NON-DIRECTIONAL BLADE
3	10311	2	BLADE BOLT NUT
4	10312	2	BLADE BOLT LOCKWASHER
5	10313	2	BLADE BOLT

DWG. NO. 20302			REV. IR	
REV	CHANGE	BY	DATE	ECN
IR	INITIAL RELEASE	M.J.T.	8/25/99	0667

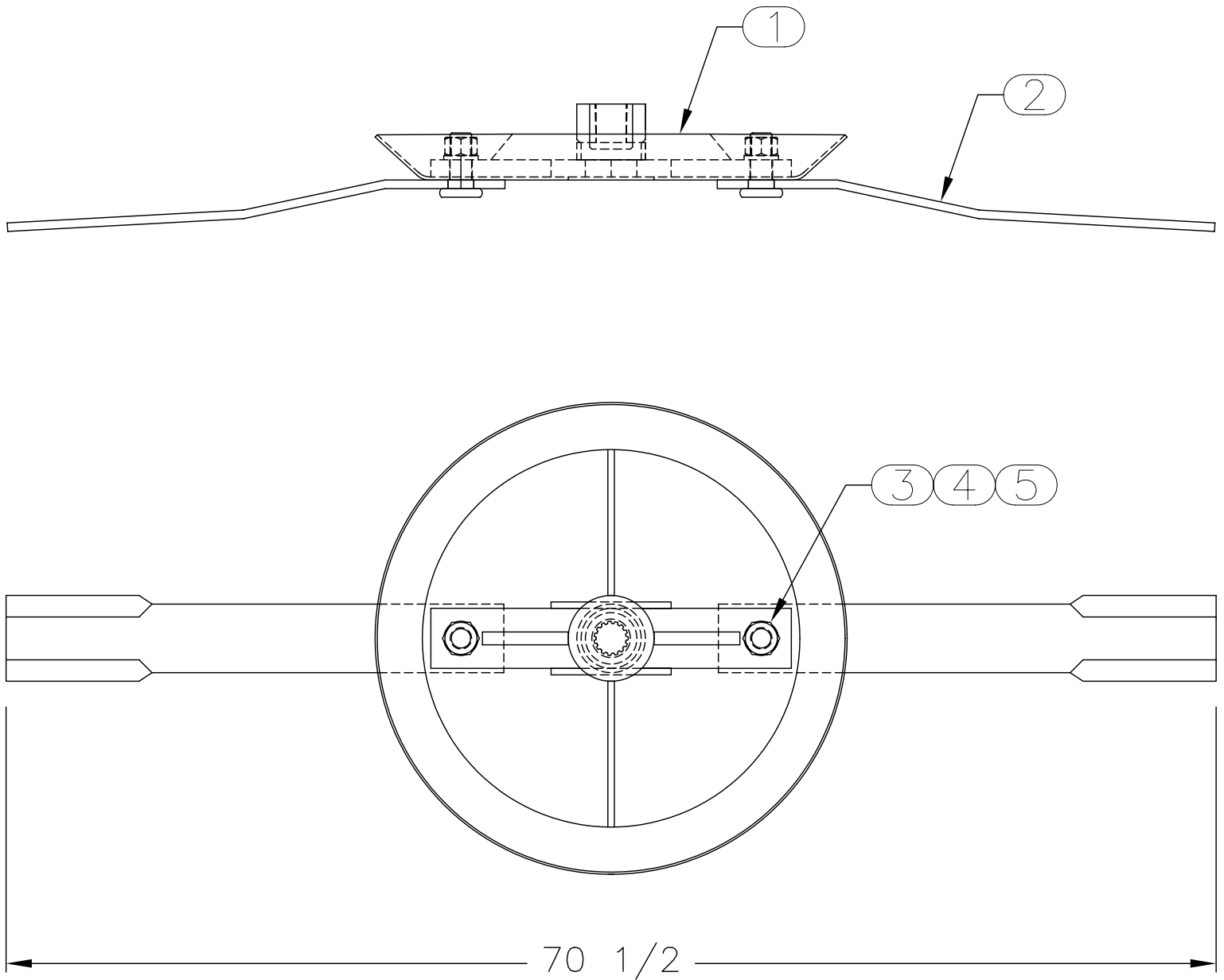

All Dimensions in Inches Unless Otherwise Specified
 Dimensions in [] are in Millimeters

Tolerances Unless Otherwise Specified
 Fractional Dimensions $\pm 1/16"$ Angular Dimensions $\pm 1^\circ$
 Decimal Dim. to Limits Shown All holes to be $\begin{matrix} +0 \\ -1/32 \end{matrix}$

DRAWN BY	M.J.T.	8/25/99	EVH Manufacturing Co. LORIS S.C.	
CHECKED BY				
MATERIAL	R.M.N.		APPLICATION	OLD PART #
MANUFACTURED BY: HARDEE WILLIAMS			T-572-LT	----
			DESCRIPTION BLADE HOLDER W/BLADES COMPLETE	
DO NOT SCALE	A	DWG. NO.	20302	
	DWG SIZE			

10345 Gearbox

(125H.P. Gearbox 1: 1 Ratio)

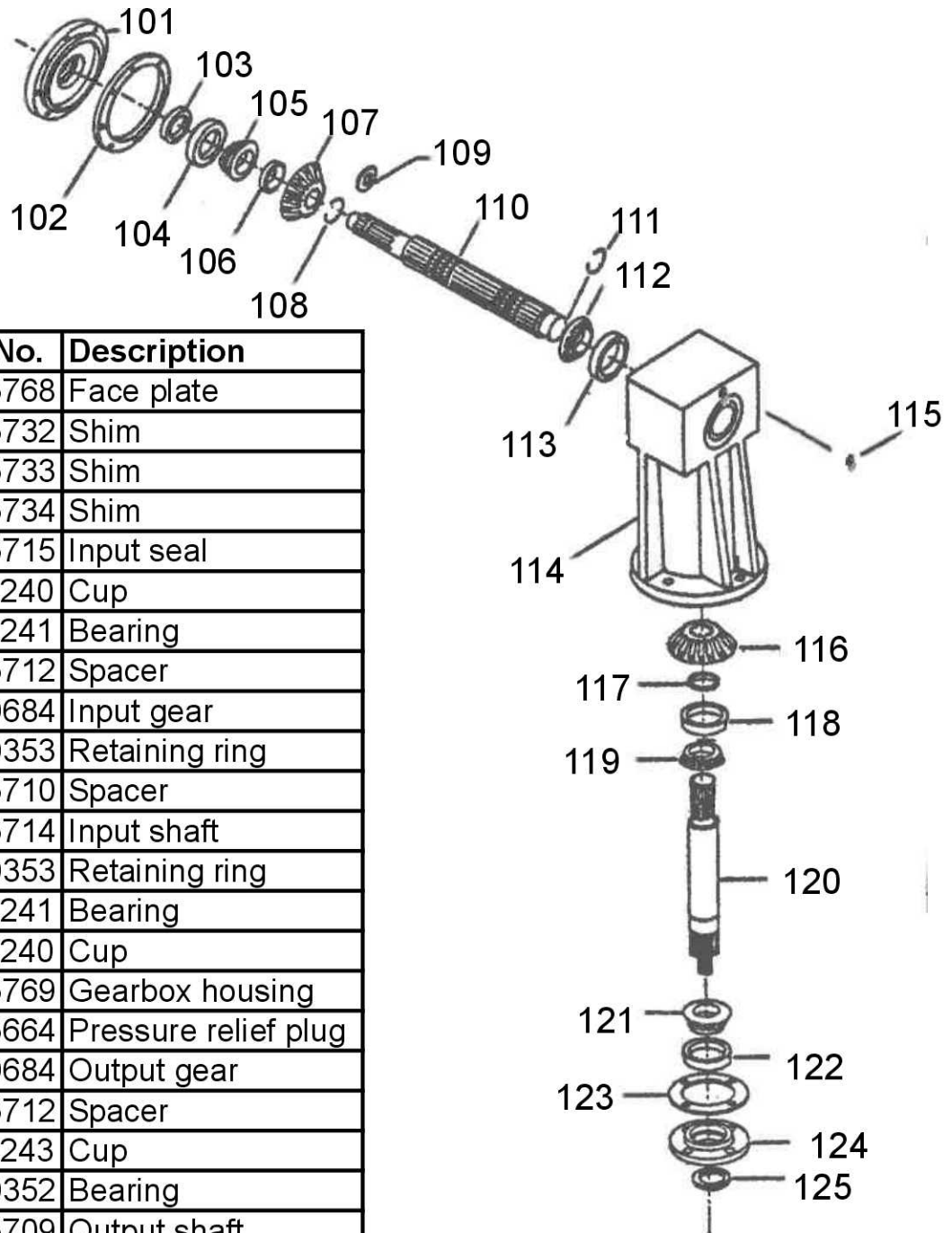

Key #	Part No.	Description
101	15768	Face plate
102	15732	Shim
	15733	Shim
	15734	Shim
103	15715	Input seal
104	11240	Cup
105	11241	Bearing
106	15712	Spacer
107	10684	Input gear
108	10353	Retaining ring
109	15710	Spacer
110	15714	Input shaft
111	10353	Retaining ring
112	11241	Bearing
113	11240	Cup
114	15769	Gearbox housing
115	15664	Pressure relief plug
116	10684	Output gear
117	15712	Spacer
118	11243	Cup
119	10352	Bearing
120	15709	Output shaft
121	10352	Bearing
122	11242	Cup
123	15706	Bottom cover
124	15705	Shim
125	10354	Output seal

DRIVESHAFT 10378

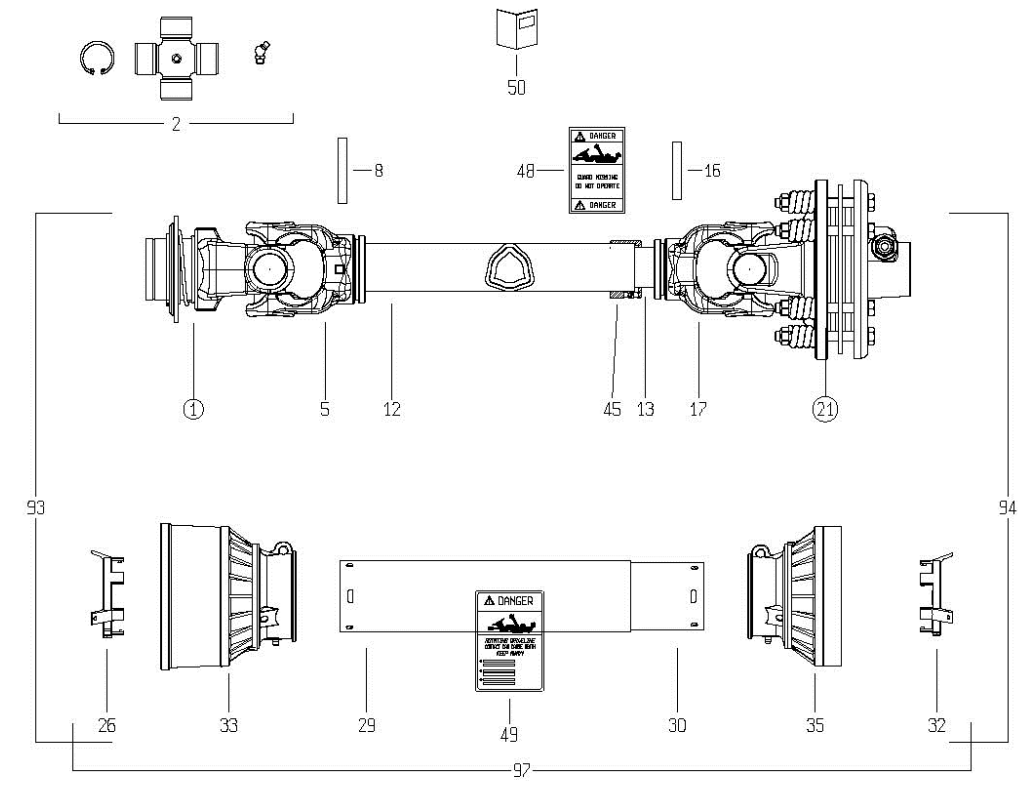

①

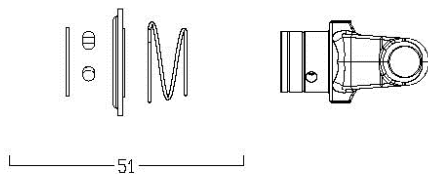

②①

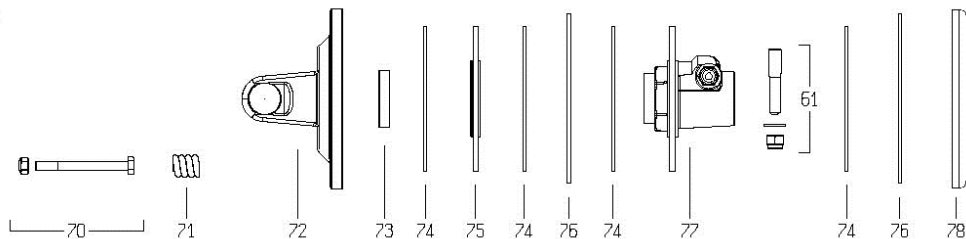

Key #	Part #	Description	Key #	Part #	Description
1	15571	Yoke – 1-3/8” Z6	70	15584	Cross Journal Assem.
2	15572	Cross Kit-Zerk in Body	71	15561	Coil Spring-Clutch
5	15573	Yoke-Outer Tube	72	16703	Flanged Yoke
8	98756	Flexible Roll Pin-Outer	73	16865	Bushing-Clutch
16	98160	Flexible Roll Pin-Inner	74	16864	Lining – Friction Disc
17	15577	Yoke-Inner Tube	75	16866	Lining Support
21	16870	Clutch – 1-3/8” Z 6	76	16704	Inner Plate
26	98142	Shield Support-Outer	77	16869	Flange Hub 1-3/8 Z6
32	98143	Shield Support-Inner	78	15799	Clutch Pressure Plate
51	16702	Ball Collar Kit	97	16868	Complete Shield Kit
61	15583	Pin			