

ITEM NO.	PART NUMBER	QTY REQD.	NOMENCLATURE OR DESCRIPTION
1	30896	1	100 GAL. FRAME WELDMENT
2	14986	1	100 GALLON BLACK POLY TANK
3	10803	3	3/4" RUBBER SEAL
4	30331	2	TANK STRAP WELDMENT
5	10175	8	LOCK NUT (3/8" PLATED)
6	10202	12	FLAT WASHER (3/8" PLATED)
7	10031	4	HEX BOLT (3/8" X 1" GR.5 PLATED)
8	13353	2	ELBOW (1/2" HB X 3/4" PT
9	13361	1	1 1/4" NPT X 3/4" HB ELBOW
10	10797	13'	3/4" I.D. HOSE, CLEAR
11	13531	2	5/8" X 3/4" S.S. HS CLAMP
12	10339	2	POP RIVOTS
13	11727	1	SERIAL NUMBER PLATE
14	13860	1	1" CAP (POLY)
15	10773	1	AGITATOR
16	13731	1	NIPPLE 1" MNPT X 13"
17	13079	1	U BOLT, 1/4"-20 X 1-1/4" X 2-1/4" X 1-1/4"
18	10154	2	5/16" PLATED LOCK NUT
19	10201	2	5/16" WASHER
20	10799	2	TANK FITTING
21	10800	2	TANK FITTING O-RING
22	10804	1	BALL
23	10801	3	3/4"HB X 3/4"NPT "L" W/FLANGE
24	10818	1	1 1/4" TANK FITTING NUT
25	10816	1	3/4" DBL. THRD. POLY TANK FITTING
26	14052	1	FITTING - 1 1/4" AV
27	14077	1	O-RING
28	10802	3	3/4" FNPT NUT W/FLANGE
29	10804	1	INDICATOR FLOAT (NOT SHOWN)
30	11850	1	WEBSITE DECAL (NOT SHOWN)
31	15448	4	CLIP FOR 15447 RATCHET JACK PIN
32	15477	1	2" STRAPPING (112" LG.)
33	15852	2	RED DEFLECTOR (NOT SHOWN)

DWG. NO.			REV.	
30903			C	
REV	CHANGE	BY	DATE	ECN
IR	INITIAL RELEASE	W.E.S.	9/10/98	---
A	CHANGE PART NUMBER	T.R.M.	1/31/00	0743
B	CHANGE SERIAL # PLATE	T.R.M.	6/8/00	0792
C	REMOVED ITEM 30332	B.C	6/27/07	1153

ADD THIS REVISION AT NEXT  
DRAWING CHANGE

See ECR Change #0980 for Details  
Add Qty. (1) Each 15852, 15853

All Dimensions in Inches Unless Otherwise Specified  
Dimensions in [ ] are in Millimeters

Tolerances Unless Otherwise Specified  
Fractional Dimensions ±1/16" Angular Dimensions ±1°  
Decimal Dim. to Limits Shown All holes to be  $\frac{+0}{-0.015}$

DRAWN BY	W.E.S.	9/10/98
CHECKED BY		
MATERIAL	R.M.N.	

**HARDEE BY  
EVH MFG. CO.  
LORIS S.C.**

APPLICATION	OLD PART #
100 GAL. SK	----
DESCRIPTION	100 GALLON TANK AND FRAME ASSEMBLY

MANUFACTURED BY  
HARDEE MFG. CO., LLC

DO NOT SCALE	A	DWG. NO.
DWG SIZE	SHEET 1 OF 4	30903

DWG. NO.

30903

REV.

C

ADD THIS REVISION AT NEXT  
DRAWING CHANGE

---

See ECR Change #0980 for Details  
Add Qty. (1) Each 15852, 15853

REV	CHANGE	BY	DATE	ECN
IR	INITIAL RELEASE	W.E.S.	9/10/98	---
A	CHANGE PART NUMBER	T.R.M.	1/31/00	0743
B	CHANGE SERIAL # PLATE	T.R.M.	6/8/00	0792
C	REMOVED ITEM 30332	B.C	6/27/07	1153

EVH MFG. CO.

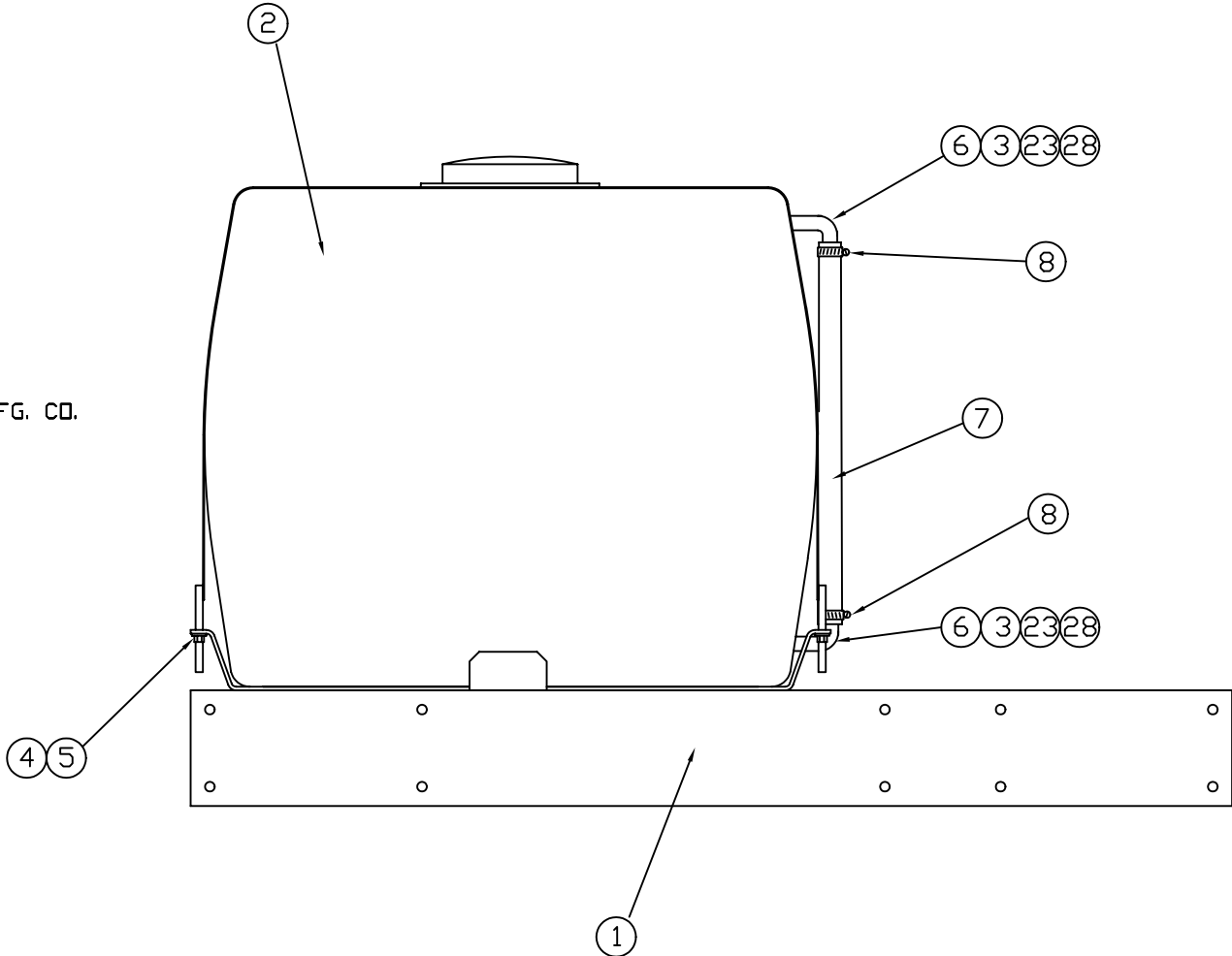

RIGHT SIDE VIEW

All Dimensions in Inches Unless Otherwise Specified  
Dimensions in [ ] are in Millimeters

Tolerances Unless Otherwise Specified  
Fractional Dimensions  $\pm 1/16"$  Angular Dimensions  $\pm 1^\circ$   
Decimal Dim. to Limits Shown All holes to  $be \begin{matrix} +0 \\ \pm 1/32 \end{matrix}$

DRAWN BY	W.E.S.	9/10/98
CHECKED BY		
MATERIAL	R.M.N.	

**HARDEE BY  
EVH MFG. CO.  
LORIS S.C.**

APPLICATION	OLD PART #
100 GAL. SK	----
DESCRIPTION 100 GALLON TANK AND FRAME ASSEMBLY	

MANUFACTURED BY  
HARDEE MFG. CO., LLC

DO NOT SCALE	A	DWG. NO.
DWG SIZE	SHEET 2 OF 4	30903

**ADD THIS REVISION AT NEXT  
DRAWING CHANGE**

---

See ECR Change #0980 for Details  
Add Qty. (1) Each 15852, 15853

DWG. NO.			REV.	
<b>30903</b>			<b>C</b>	
REV	CHANGE	BY	DATE	ECN
IR	INITIAL RELEASE	W.E.S.	9/10/98	---
A	CHANGE PART NUMBER	T.R.M.	1/31/00	0743
B	CHANGE SERIAL # PLATE	T.R.M.	6/8/00	0792
C	REMOVED ITEM 30332	B.C	6/27/07	1153

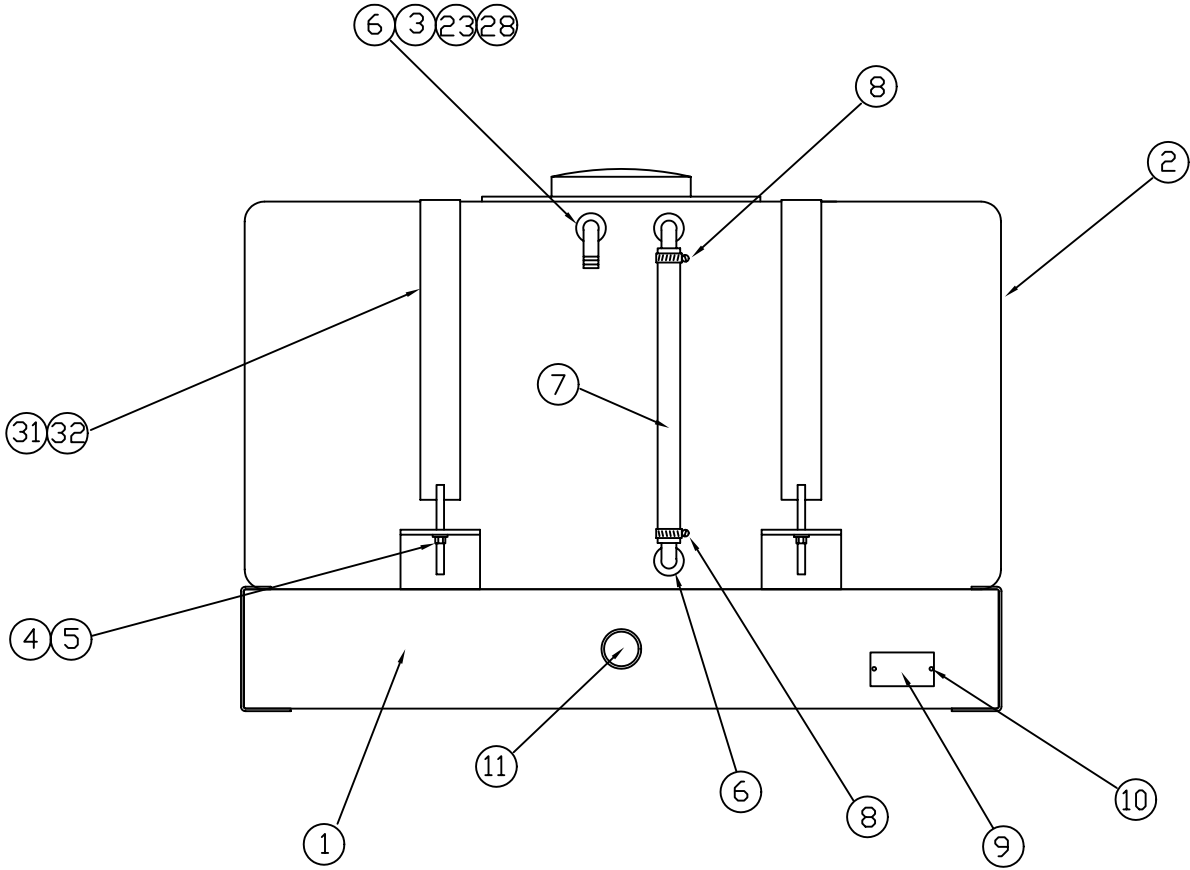

FRONT VIEW

All Dimensions in Inches Unless Otherwise Specified  
Dimensions in [ ] are in Millimeters

Tolerances Unless Otherwise Specified  
Fractional Dimensions  $\pm 1/16"$  Angular Dimensions  $\pm 1^\circ$   
Decimal Dim. to Limits Shown All holes to be  $+0$ / $-0.003$

DRAWN BY	W.E.S.	9/10/98	<b>HARDEE BY EVH MFG. CO. LORIS S.C.</b>	
CHECKED BY			APPLICATION	OLD PART #
MATERIAL	R.M.N.		100 GAL SK	----
MANUFACTURED BY HARDEE MFG. CO., LLC			DESCRIPTION 100 GALLON TANK AND FRAME ASSEMBLY	
DO NOT SCALE	A	DWG. NO.	SHEET 3 OF 4	
	DWG SIZE	<b>30903</b>		

DWG. NO.

30903

REV.

C

REV	CHANGE	BY	DATE	ECN
IR	INITIAL RELEASE	W.E.S.	9/10/98	---
A	CHANGE PART NUMBER	T.R.M.	1/31/00	0743
B	CHANGE SERIAL # PLATE	T.R.M.	6/8/00	0792
C	REMOVED ITEM 30332	B.C	6/27/07	1153

ADD THIS REVISION AT NEXT  
DRAWING CHANGE

See ECR Change #0980 for Details  
Add Qty. (1) Each 15852, 15853

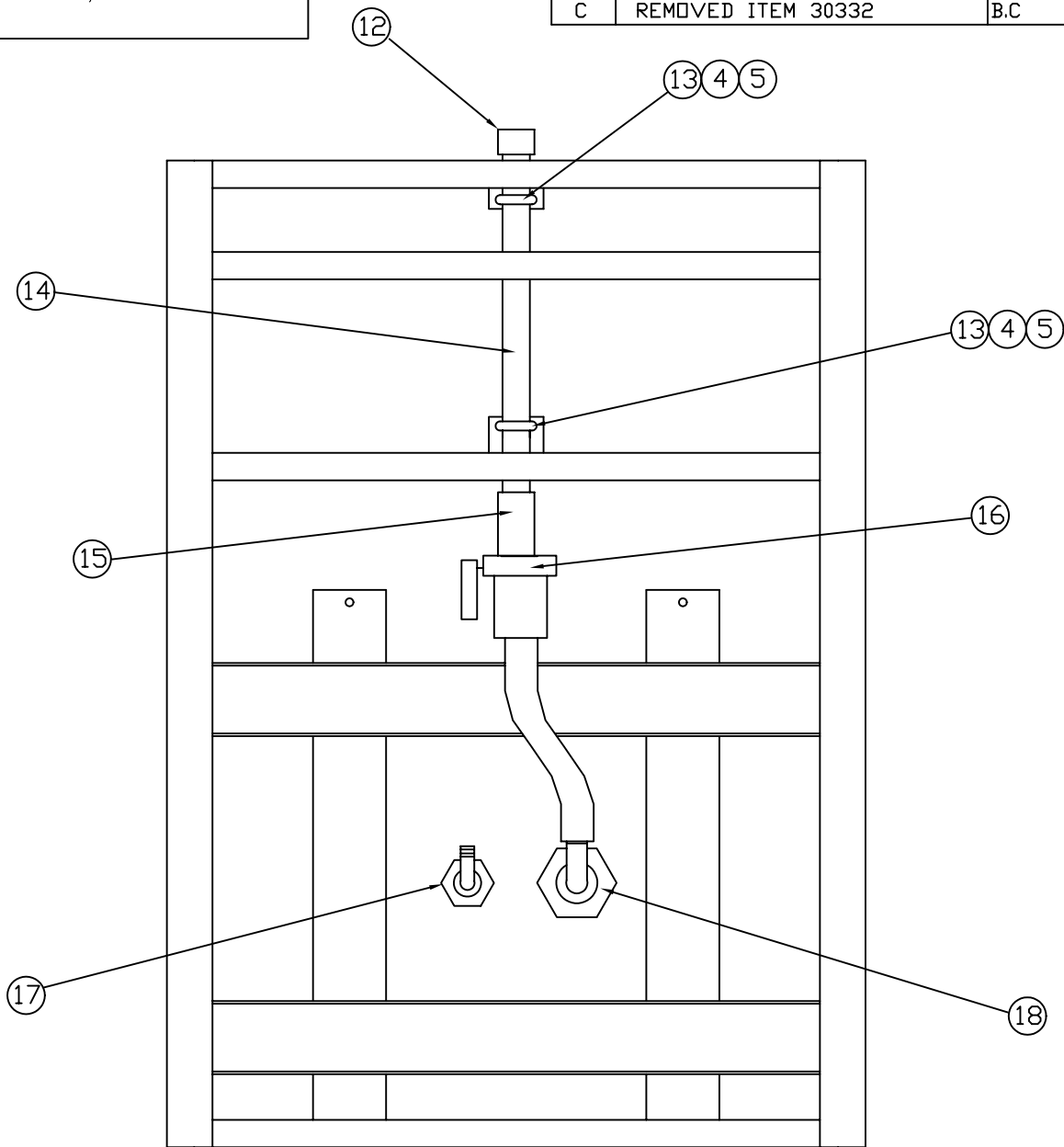

BOTTOM VIEW

DRAWN BY	W.E.S.	9/10/98
CHECKED BY		
MATERIAL	R.M.N.	

**HARDEE BY  
EVH MFG. CO.  
LORIS S.C.**

All Dimensions in Inches Unless Otherwise Specified  
Dimensions in [ ] are in Millimeters

Tolerances Unless Otherwise Specified  
Fractional Dimensions  $\pm 1/16"$  Angular Dimensions  $\pm 1^\circ$   
Decimal Dim. to Limits Shown All holes to  $be \begin{matrix} +0 \\ \pm 1/32 \end{matrix}$

MANUFACTURED BY  
HARDEE MFG. CO., LLC

APPLICATION 100 GAL SK  
OLD PART # ----

DESCRIPTION 100 GALLON  
TANK AND FRAME ASSEMBLY

DO NOT SCALE DWG SIZE A DWG. NO. 30903  
SHEET 4 OF 4