

ITEM NO.	PART NUMBER	QTY REQD.	NOMENCLATURE OR DESCRIPTION
1	30835	1	FRAME WELDMENT
2	30226	2	TOP BAND WELDMENT
3	30308	2	SADDLE WELDMENT
4	33030	1	HANDGUN CONTROL STAND WELDMENT
5	30561	1	TRAILER STAND WELDMENT
6	13196	2	TIRE ON WHEEL-18/850 X 8/4 HOLE
7	10773	1	AGITATOR
8	10761	1	POLYETHYLENE TANK / 55 GAL.
9	13607	1	STRAINER/POLYPRO/50 MESH
10	14052	1	1 1/4" AV POLY TANK FITTING
11	10818	1	1 /14" TANK FITTING NUT
12	14077	1	LARGE VITON O-RING
13	13757	1	1 1/4" M-NPT X 3/4 F-NPT REDUCER
14	13492	3	3/4" NPT POLY CLOSE NIPPLE
15	13007	1	3/4" FPT PP BALL VALVE
16	13695	1	3/4" F-NPT THREADED ELBOW
17	13355	4	3/4NPT X3/4 POLY HOSE BARB EL.
18	10801	3	3/4"HB X 3/4" NPT "L" W/FLANGE
19	10816	1	3/4" DT TANK FITTING
20	10799	2	SMALL TANK FITTING NUT
21	10800	2	SMALL VITON O-RING
22	10797	24"	3/4" I.D. X 40 PSI CLEAR HOSE
23	10804	1	LEVEL INDICATOR FLOAT
24	10802	3	3/4" FNPT TANK FITTING NUT W/FLANGE
25	10803	3	3/4" RUBBER SEAL

DWG. NO.			REV.	
30913			C	
REV	CHANGE	BY	DATE	ECN
IR	INITIAL RELEASE	W.E.S.	3/1/99	---
A	B.O.M. CHANGES	M.J.T.	5/18/99	0602
B	CHANGE PART NUMBER	T.R.M.	1/31/00	0743
C	CHANGE SERIAL # PLATE	T.R.M.	6/8/00	0792

ADD THIS REVISION AT NEXT  
DRAWING CHANGE

---

See ECR Change #0980 for Details  
Add Qty. (1) Each 15852, 15853

26	14275	2	4 BOLT STUDED HUB/BEAR/1" SEAL
27	10033	6	HEX BOLT 3/8 X 2 GR.5 PLATED
28	10035	4	HEX BOLT 3/8 X 3 GR.5 PLATED
29	10202	20	FLAT WASHER 3/8" PLATED
30	10175	10	LOCK NUT 3/8" PLATED
31	10339	2	RIVET FOR SERIAL # PLATE
32	11727	1	SERIAL NUMBER PLATE
33	13531	2	STAINLESS STEEL CLAMP FITS 5/8 TO 3/4
34	10416	1	5/16 DIA. X 3 LOCK PIN

All Dimensions in Inches Unless Otherwise Specified  
Dimensions in [ ] are in Millimeters

Tolerances Unless Otherwise Specified  
Fractional Dimensions ±1/16" Angular Dimensions ±1°  
Decimal Dim. to Limits Shown All holes to be  $\begin{matrix} +0 \\ \pm 1/32 \end{matrix}$

DRAWN BY	W.E.S.	3/1/99	<b>HARDEE BY EVH MFG. CO. LORIS S.C.</b>	
CHECKED BY				
MATERIAL	R.M.N.		APPLICATION	OLD PART #
MANUFACTURED BY HARDEE MFG. CO., LLC			T55 SPRAYER	----
			DESCRIPTION	55 GALLON TANK AND FRAME ASSEMBLY
DO NOT SCALE	A	DWG. NO.	SHEET 1 OF 3	
			30913	

DWG. NO.

30913

REV.

C

ADD THIS REVISION AT NEXT  
DRAWING CHANGE

---

See ECR Change #0980 for Details  
Add Qty. (1) Each 15852, 15853

REV	CHANGE	BY	DATE	ECN
IR	INITIAL RELEASE	W.E.S.	3/1/99	---
A	B.D.M. CHANGES	M.J.T.	5/18/99	0602
B	CHANGE PART NUMBER	T.R.M.	1/31/00	0743
C	CHANGE SERIAL # PLATE	T.R.M.	6/8/00	0792

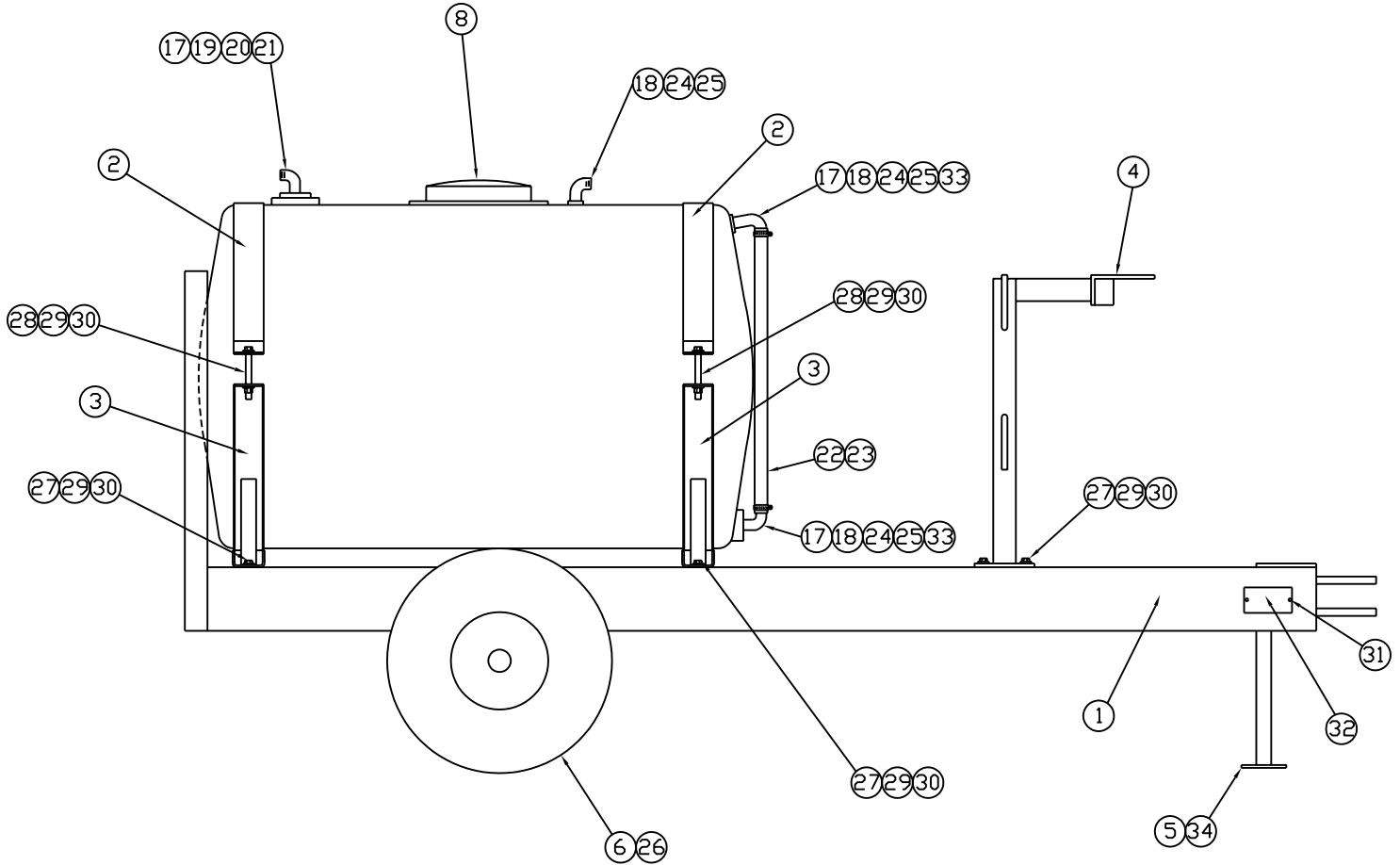

RIGHT SIDE VIEW

ITEM ⑦ AGITATOR LOCATED INSIDE  
TANK ON BOTTOM.

All Dimensions in Inches Unless Otherwise Specified  
Dimensions in [ ] are in Millimeters

Tolerances Unless Otherwise Specified  
Fractional Dimensions ±1/16" Angular Dimensions ±1°  
Decimal Dim. to Limits Shown All holes to be  $\frac{+0}{-0.003}$

DRAWN BY	W.E.S.	3/1/99
CHECKED BY		
MATERIAL	R.M.N.	

MANUFACTURED BY  
HARDEE MFG. CO., LLC

**HARDEE BY  
EVH MFG. CO.  
LORIS S.C.**

APPLICATION T55 SPRAYER	OLD PART # ----
----------------------------	--------------------

DESCRIPTION 55 GALLON TANK AND FRAME ASSEMBLY
---

DO NOT SCALE	A DWG. SIZE	DWG. NO. SHEET 2 OF 3	30913
--------------	----------------	--------------------------	-------

DWG. NO.

30913

REV.

C

ADD THIS REVISION AT NEXT  
DRAWING CHANGE

See ECR Change #0980 for Details  
Add Qty. (1) Each 15852, 15853

REV	CHANGE	BY	DATE	ECN
IR	INITIAL RELEASE	W.E.S.	3/1/99	---
A	B.O.M. CHANGES	M.J.T.	5/18/99	0602
B	CHANGE PART NUMBER	T.R.M.	1/31/00	0743
C	CHANGE SERIAL # PLATE	T.R.M.	6/8/00	0792

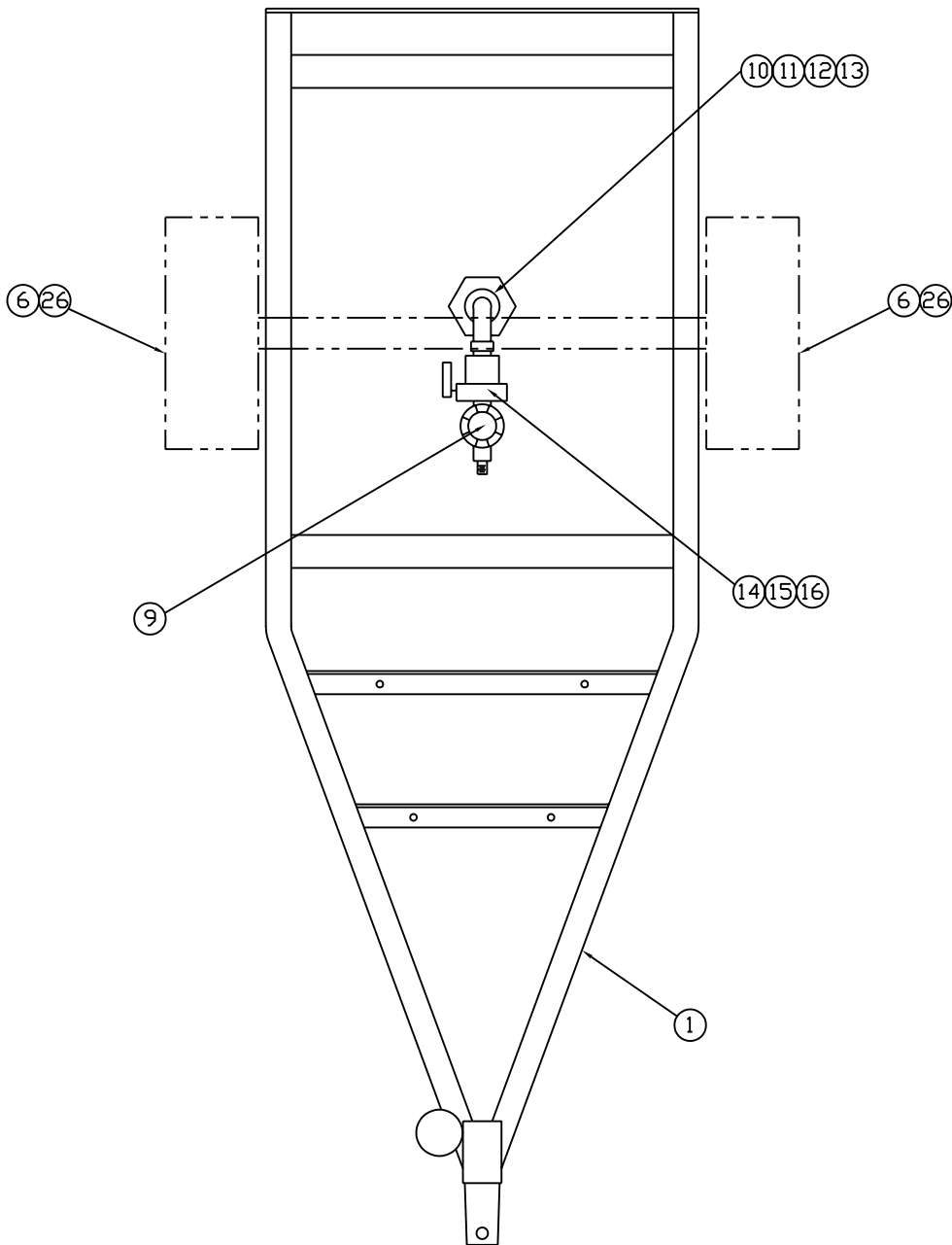

BOTTOM VIEW

ITEM ⑦ AGITATOR LOCATED INSIDE  
TANK ON BOTTOM.

All Dimensions in Inches Unless Otherwise Specified  
Dimensions in [ ] are in Millimeters

Tolerances Unless Otherwise Specified  
Fractional Dimensions  $\pm 1/16"$  Angular Dimensions  $\pm 1^\circ$   
Decimal Dim. to Limits Shown All holes to be  $+0$   
 $-0.0015$

DRAWN BY	W.E.S.	3/1/99
CHECKED BY		
MATERIAL	R.M.N.	

**HARDEE BY  
EVH MFG. CO.  
LORIS S.C.**

APPLICATION T55 SPRAYER OLD PART # ----

DESCRIPTION 55 GALLON TANK AND FRAME ASSEMBLY

DO NOT SCALE DWG SIZE A SHEET 3 OF 3 DWG. NO. 30913

MANUFACTURED BY HARDEE MFG. CO., LLC